

SERVICE MANUAL

notebook

PA70HP6(-G) / PA71HP6



Notebook Computer
PA70HP6(-G) / PA71HP6
Service Manual

Notice

The company reserves the right to revise this publication or to change its contents without notice. Information contained herein is for reference only and does not constitute a commitment on the part of the manufacturer or any subsequent vendor. They assume no responsibility or liability for any errors or inaccuracies that may appear in this publication nor are they in anyway responsible for any loss or damage resulting from the use (or misuse) of this publication.

This publication and any accompanying software may not, in whole or in part, be reproduced, translated, transmitted or reduced to any machine readable form without prior consent from the vendor, manufacturer or creators of this publication, except for copies kept by the user for backup purposes.

Brand and product names mentioned in this publication may or may not be copyrights and/or registered trademarks of their respective companies. They are mentioned for identification purposes only and are not intended as an endorsement of that product or its manufacturer.

Version 1.0
July 2017

Trademarks

Intel and Intel Core are trademarks of Intel Corporation.

Windows[®] is a registered trademark of Microsoft Corporation.

Other brand and product names are trademarks and /or registered trademarks of their respective companies.



About this Manual

This manual is intended for service personnel who have completed sufficient training to undertake the maintenance and inspection of personal computers.

It is organized to allow you to look up basic information for servicing and/or upgrading components of the *PA70HP6(-G) / PA71HP6* series notebook PC.

The following information is included:

Chapter 1, Introduction, provides general information about the location of system elements and their specifications.

Chapter 2, Disassembly, provides step-by-step instructions for disassembling parts and subsystems and how to upgrade elements of the system.

Appendix A, Part Lists

Appendix B, Schematic Diagrams

Appendix C, Updating the FLASH ROM BIOS

IMPORTANT SAFETY INSTRUCTIONS

Follow basic safety precautions, including those listed below, to reduce the risk of fire, electric shock and injury to persons when using any electrical equipment:

1. Do not use this product near water, for example near a bath tub, wash bowl, kitchen sink or laundry tub, in a wet basement or near a swimming pool.
2. Avoid using a telephone (other than a cordless type) during an electrical storm. There may be a remote risk of electrical shock from lightning.
3. Do not use the telephone to report a gas leak in the vicinity of the leak.
4. Use only the power cord and batteries indicated in this manual. Do not dispose of batteries in a fire. They may explode. Check with local codes for possible special disposal instructions.
5. This product is intended to be supplied by a Listed Power Unit as follows:
 - AC Input of 100 - 240V, 50 - 60Hz, DC Output of 19V, 10.5A (**200** Watts) minimum AC/DC Adapter.

FCC Statement

This device complies with Part 15 of the FCC Rules. Operation is subject to the following two conditions:

This device may not cause harmful interference.

This device must accept any interference received, including interference that may cause undesired operation.

Instructions for Care and Operation

The notebook computer is quite rugged, but it can be damaged. To prevent this, follow these suggestions:

1. **Don't drop it, or expose it to shock.** If the computer falls, the case and the components could be damaged.



2. **Keep it dry, and don't overheat it.** Keep the computer and power supply away from any kind of heating element. This is an electrical appliance. If water or any other liquid gets into it, the computer could be badly damaged.

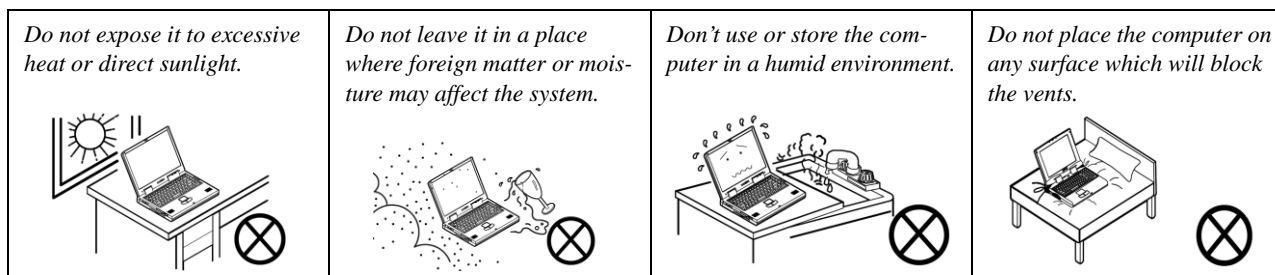

3. **Follow the proper working procedures for the computer.** Shut the computer down properly and don't forget to save your work. Remember to periodically save your data as data may be lost if the battery is depleted.

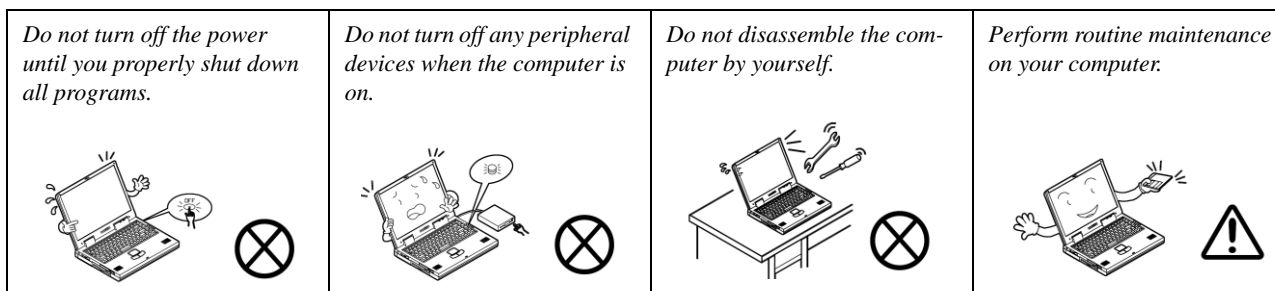

4. **Avoid interference.** Keep the computer away from high capacity transformers, electric motors, and other strong magnetic fields. These can hinder proper performance and damage your data.
5. **Take care when using peripheral devices.**

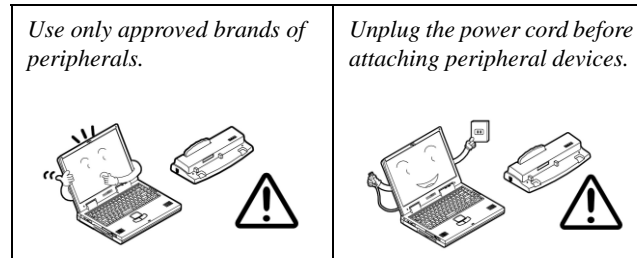

Power Safety

The computer has specific power requirements:

- Only use a power adapter approved for use with this computer.
- Your AC adapter may be designed for international travel but it still requires a steady, uninterrupted power supply. If you are unsure of your local power specifications, consult your service representative or local power company.
- The power adapter may have either a 2-prong or a 3-prong grounded plug. The third prong is an important safety feature; do not defeat its purpose. If you do not have access to a compatible outlet, have a qualified electrician install one.
- When you want to unplug the power cord, be sure to disconnect it by the plug head, not by its wire.
- Make sure the socket and any extension cord(s) you use can support the total current load of all the connected devices.
- Before cleaning the computer, make sure it is disconnected from any external power supplies.

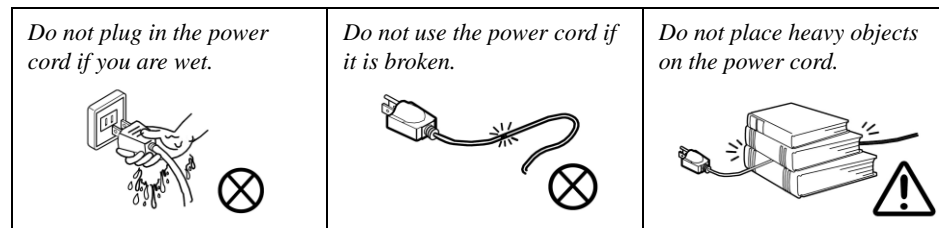

Power Safety Warning

Before you undertake any upgrade procedures, make sure that you have turned off the power, and disconnected all peripherals and cables (including telephone lines and power cord). It is advisable to also remove your battery in order to prevent accidentally turning the machine on.

Battery Precautions

- Only use batteries designed for this computer. The wrong battery type may explode, leak or damage the computer.
- Do not continue to use a battery that has been dropped, or that appears damaged (e.g. bent or twisted) in any way. Even if the computer continues to work with a damaged battery in place, it may cause circuit damage, which may possibly result in fire.
- Recharge the batteries using the notebook's system. Incorrect recharging may make the battery explode.
- Do not try to repair a battery pack. Refer any battery pack repair or replacement to your service representative or qualified service personnel.
- Keep children away from, and promptly dispose of a damaged battery. Always dispose of batteries carefully. Batteries may explode or leak if exposed to fire, or improperly handled or discarded.
- Keep the battery away from metal appliances.
- Affix tape to the battery contacts before disposing of the battery.
- Do not touch the battery contacts with your hands or metal objects.

Battery Guidelines

The following can also apply to any backup batteries you may have.

- If you do not use the battery for an extended period, then remove the battery from the computer for storage.
- Before removing the battery for storage charge it to 60% - 70%.
- Check stored batteries at least every 3 months and charge them to 60% - 70%.



Battery Disposal

The product that you have purchased contains a rechargeable battery. The battery is recyclable. At the end of its useful life, under various state and local laws, it may be illegal to dispose of this battery into the municipal waste stream. Check with your local solid waste officials for details in your area for recycling options or proper disposal.

Caution

Danger of explosion if battery is incorrectly replaced. Replace only with the same or equivalent type recommended by the manufacturer. Discard used battery according to the manufacturer's instructions.

Battery Level

Click the battery icon  in the taskbar to see the current battery level and charge status. A battery that drops below a level of 10% will not allow the computer to boot up. Make sure that any battery that drops below 10% is recharged within one week.

Related Documents

You may also need to consult the following manual for additional information:

User's Manual on CD/DVD

This describes the notebook PC's features and the procedures for operating the computer and its ROM-based setup program. It also describes the installation and operation of the utility programs provided with the notebook PC.

System Startup

1. Remove all packing materials.
2. Place the computer on a stable surface.
3. Securely attach any peripherals you want to use with the computer (e.g. keyboard and mouse) to their ports.
4. **When first setting up the computer use the following procedure** (as to safeguard the computer during shipping, the battery will be locked to not power the system until first connected to the AC/DC adapter and initially set up as below):
 - Attach the AC/DC adapter cord to the DC-In jack on the left of the computer, then plug the AC power cord into an outlet, and connect the AC power cord to the AC/DC adapter and **leave it there for 6 seconds or longer**.
 - Remove the adapter cord from the computer's DC-In jack, and then plug it back in again; the battery will now be unlocked.
5. Use one hand to raise the lid/LCD to a comfortable viewing angle (do not exceed 135 degrees); use the other hand (as illustrated in Figure 1) to support the base of the computer (**Note: Never** lift the computer by the lid/LCD).
6. Press the power button to turn the computer "on".

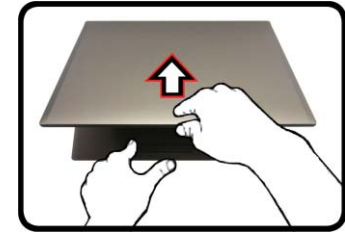



Figure 1
Opening the Lid/LCD/
Computer with AC/DC
Adapter Plugged-In



Shut Down

Note that you should always shut your computer down by choosing the **Shut down** command in **Windows** (see below). This will help prevent hard disk or system problems.

Click the icon  in the **Start Screen** and choose **Shut down** from the menu.



Or

Right-click the **Start button**  at the bottom of the **Start Screen** or the **Desktop** and choose **Shut down or sign out > Shut down** from the context menu.

Contents

Introduction1-1

Overview	1-1
Specifications	1-2
External Locator - Top View with LCD Panel Open	1-4
External Locator - Front & Right Side Views	1-5
External Locator - Left Side & Rear View	1-6
External Locator - Bottom View	1-7
Mainboard Overview - Top (Key Parts)	1-8
Mainboard Overview - Bottom (Key Parts)	1-9
Mainboard Overview - Top (Connectors)	1-10
Mainboard Overview - Bottom (Connectors)	1-11

Disassembly2-1

Overview	2-1
Maintenance Tools	2-2
Connections	2-2
Maintenance Precautions	2-3
Disassembly Steps	2-4
Removing the Keyboard	2-5
Removing the Battery	2-6
Removing the Hard Disk Drive	2-8
Removing the System Memory (RAM)	2-10
Removing the M.2 SSD Module	2-11
Removing the Wireless LAN Module	2-14
Wireless LAN, Combo, 3G & LTE Module Cables	2-15
Removing the CCD	2-16
Removing the LCD Module	2-18

Part ListsA-1

Part List Illustration Location	A-2
Top	A-3

Bottom	A-4
Main Board	A-5
HDD	A-6
LCD	A-7

Schematic Diagrams.....B-1

System Block Diagram	B-2
Processor 1/6	B-3
Processor 2/6	B-4
Processor 3/6	B-5
Processor 4/6	B-6
Processor 5/6	B-7
Processor 6/6	B-8
DDR4 CHA SO-DIMM_0	B-9
DDR4 CHB SO-DIMM_0	B-10
Panel, Inverter	B-11
Mini DP Port (Back)	B-12
Mini DP Port (Front)	B-13
HDMI Connector	B-14
VGA PCI Express	B-15
GPU Frame Buffer Partition	B-16
Frame Buffer Partition A	B-17
Frame Buffer Partition B	B-18
Frame Buffer Partition A_B	B-19
GPU Frame Buffer Partition	B-20
Frame Buffer Partition C	B-21
Frame Buffer Partition D	B-22
Frame Buffer Partition C_D	B-23
GPU Decoupling	B-24
Straps and XTAL	B-25
IFP I/O Interface	B-26

Preface

Misc - GPIO, I2C and ROM	B-27	VCore & VCCGT Output	B-59
NVIDIA Power Sequence	B-28	VCCSA	B-60
GPU NVVDD, FBVDDQ	B-29	AC_In, Charger	B-61
GPU GND	B-30	NVVDDS	B-62
PCH 1/5	B-31	NVVDD 1	B-63
PCH 2/5	B-32	NVVDD 2	B-64
PCH 3/5	B-33	FBVDDQ	B-65
PCH 4/5	B-34	LED Board	B-66
PCH 5/5	B-35	LID Board	B-67
KBC IT8587	B-36	DC Board	B-68
RGB and White KB LED	B-37	Power Board	B-69
M.2 PCIE4X SSD	B-38	Click Board	B-70
M.2 3G/LTE/WIGIG/WLAN+BT	B-39	Audio Board	B-71
Audio	B-40	USB Board	B-72
Audio Subwoofer	B-41	USB 3.0 Board	B-73
Audio Port 1	B-42	PA7 1/4	B-74
AR_TBT	B-43	PA7 2/4	B-75
AR Power	B-44	PA7 3/4	B-76
TPS65982ABZQZ	B-45	PA7 4/4	B-77
USB 3.0 Type C	B-46	Power Sequence	B-78
PS8338B	B-47	Updating the FLASH ROM BIOS..... C-1	
TPM, CCD, TP	B-48	Download the BIOS	C-1
Connectors	B-49	Unzip the downloaded files to a bootable CD/DVD or	
Fan, LID, SATA HDD	B-50	USB Flash drive	C-1
5V, 5VS, 3.3V, 3.3VS, 3.3VA	B-51	Set the computer to boot from the external drive	C-1
1.0DX_VCCSTG/VCCSFR_OC/2.5V	B-52	Use the flash tools to update the BIOS	C-2
1V8_RUN/AON, NV3V3	B-53	Restart the computer (booting from the HDD)	C-2
PEX_VDD	B-54		
VDD3, VDD5	B-55		
DDR 1.2V / 0.6VS	B-56		
Power 1.0V, VCCIO	B-57		
VCC_Core	B-58		

Chapter 1: Introduction

Overview

This manual covers the information you need to service or upgrade the **PA70HP6(-G) / PA71HP6** series notebook computer. Information about operating the computer (e.g. getting started, and the *Setup* utility) is in the *User's Manual*. Information about drivers (e.g. VGA & audio) is also found in the *User's Manual*. The manual is shipped with the computer.

Operating systems (e.g. *Windows 10*, etc.) have their own manuals as do application softwares (e.g. word processing and database programs). If you have questions about those programs, you should consult those manuals.

The **PA70HP6(-G) / PA71HP6** series notebook is designed to be upgradeable. See [Disassembly on page 2 - 1](#) for a detailed description of the upgrade procedures for each specific component. Please take note of the warning and safety information indicated by the “” symbol.

The balance of this chapter reviews the computer's technical specifications and features.

Introduction

Specifications



Latest Specification Information

The specifications listed here are correct at the time of sending them to the press. Certain items (particularly processor types/speeds) may be changed, delayed or updated due to the manufacturer's release schedule. Check with your service center for more details.



CPU Speed & Computer in DC Mode

Note that when the computer is in DC mode (powered by the battery only) the CPU may not run at full speed. This is a design feature implemented in order to protect the battery.



SO-DIMM Memory Types

All SO-DIMM memory modules installed in the system should be identical (the same size and brand) in order to prevent unexpected system behavior.

Do not mix SO-DIMM memory module sizes and brands otherwise unexpected system problems may occur.

Processor Options

i7-7820HK (2.90GHz)

6MB Smart Cache, 14nm, DDR4-2400MHz, TDP 45W

i5-7700HQ (2.80GHz)

6MB Smart Cache, 14nm, DDR4-2400MHz, TDP 45W

Core Logic

Intel® HM175 Express Chipset

LCD Options

17.3" (43.94cm), 16:9, UHD (3840x2160)/*QHD (2560x1440)/FHD (1920x1080)

***Note:** QHD panels are available for systems with NVIDIA® G-SYNC™ Technology only

BIOS

AMI BIOS (64Mb SPI Flash-ROM)

Memory

Two 260 Pin SO-DIMM Sockets Supporting **DDR4 2400MHz** Memory

(The real memory operating frequency depends on the FSB of the processor.)

Memory Expandable from **8GB (minimum)** up to **32GB (maximum)**

Compatible with 4GB, 8GB or 16GB Modules

Security

Security (Kensington® Type) Lock Slot

BIOS Password

Intel PTT for Systems Without TPM Hardware

(**Factory Option**) TPM 2.0

(**Factory Option**) Fingerprint Reader Module

Video Adapter Options

Microsoft Hybrid Graphics Mode

Supports up to 4 Active Displays

Supports NVIDIA Surround View via HDMI x 1 and MiniDP x2

Intel Integrated GPU

Intel® HD Graphics 630

Dynamic Frequency

Intel Dynamic Video Memory Technology

Microsoft DirectX®12 Compatible

NVIDIA® Discrete GPU

NVIDIA® GeForce GTX 1060

6GB GDDR5 Video RAM

Microsoft DirectX®12 Compatible

Supports GPU Overclocking

Storage

One changeable 2.5" (6cm) **7.0mm/9.5mm (h) SATA** (Serial) Hard Disk Drive/Solid State Drive (SSD)

(**Factory Option**) **Two SATA** M.2 2280 SSDs supporting RAID level 0/1

Or

(**Factory Option**) **One PCIe Gen3 x4** M.2 2280 SSD and **one PCIe Gen3 x2** M.2 2280 SSD

Pointing Device

(**Factory Option**) Built-In Secure Pad (with Microsoft PTP Multi Gesture & Scrolling Functionality)

Or

(**Factory Option**) Built-in Touchpad (with Microsoft PTP Multi Gesture & Scrolling Functionality)

Keyboard

(**Factory Option**) Full-size **Illuminated White LED** Winkey Keyboard (with numeric keypad)

Or

(**Factory Option**) **Full Color Illuminated** Full-size Winkey Keyboard (with numeric keypad)

Audio

High Definition Audio Compliant Interface

S/PDIF Digital Output

Two Speakers

Sound BlasterX® Pro-Gaming 720°

ANSP™ 3D sound technology on headphone output

Built-In Array Microphone

One Sub-Woofer

Note: External 5.1CH Audio Output Supported by 2-in1 Audio, Microphone-In and Headphone-Out Jacks

Card Reader

Embedded Multi-In-1 Push-Push Card Reader

MMC (MultiMedia Card)/RS MMC

SD (Secure Digital)/Mini SD/SDHC/ SDXC (up to UHS-II)

Communication

Built-In 10/100/1000Mb Base-TX Ethernet LAN

2.0M FHD PC Camera Module

WLAN/ Bluetooth M.2 Modules:

(**Factory Option**) Intel® Wireless-AC 8265 Wireless LAN (802.11ac) + Bluetooth

(**Factory Option**) Intel® Wireless-AC 3168 Wireless LAN (802.11ac) + Bluetooth

(**Factory Option**) Qualcomm® Atheros Killer™ Wireless-AC 1535 Wireless LAN (802.11ac) + Bluetooth

(**Factory Option**) Qualcomm® Wireless LAN (802.11ad) + Bluetooth

M.2 Slots

Slot WLAN for **Combo WLAN and Bluetooth** Module

Slot SSD1 for **SATA or PCIe Gen3 x4 SSD**

Slot SSD2 for **SATA or PCIe Gen3 x2 SSD**

**Intel® Optane™ SSD Module Installation**

Service personnel please note that Intel® Optane™ modules must be installed in the SSD1 slot.

Interface

One USB 3.0 (USB 3.1 Gen 1) Type-C Port*

*The maximum amount of current supplied by USB Type-C ports is 500mA (USB 2.0)/900mA (USB 3.1).

Or

(**Factory Option**) One USB 3.1 Gen 2/Thunderbolt 3 Combo Port (Type-C)

Four USB 3.0 (USB 3.1 Gen 1) Ports (Including one AC/DC Powered USB port)

Two Mini DisplayPorts (1.3)

One HDMI-Out Port

One 2-In-1 Audio Jack (Line-Out & S/PDIF-Out (Optical) Combo Jack)

One Microphone-In Jack

One Headphone-Out Jack

One RJ-45 LAN Jack

One DC-In Jack

Environmental Spec**Temperature**

Operating: 5°C - 35°C

Non-Operating: -20°C - 60°C

Relative Humidity

Operating: 20% - 80%

Non-Operating: 10% - 90%

Power

Embedded 4-Cell Polymer Battery Pack, 66WH

Full Range AC/DC Adapter

AC Input: 100 - 240V, 50 - 60Hz

DC Output: 19V, 10.5A (**200W**)

Dimensions & Weight

418.5mm (w) * 287mm (d) * 24.9mm (h)

3.0kg (Barebone with 66WH Battery)

Introduction

Figure 1
Top View

External Locator - Top View with LCD Panel Open

1. PC Camera
2. *PC Camera LED
**When the PC camera is in use, the LED will be illuminated.*
3. Built-In Array Microphone
4. LCD
5. Speakers
6. Power Button
7. Keyboard
8. Touchpad & Buttons
9. Fingerprint Reader (Optional)



External Locator - Front & Right Side Views

FRONT VIEW



Figure 2
Front View
1. LED Indicator

RIGHT SIDE VIEW



Figure 3
Right Side View
1. Headphone-Out Jack
2. Microphone-In Jack
3. Line & S/PDIF Combo Jack
4. Multi-in-1 Card Reader
5. USB 3.0 (USB 3.1 Gen 1) Port
6. *Powered USB 3.0 (USB 3.1 Gen 1) Port
7. RJ-45 LAN Jack
8. Security Lock Slot

Introduction

External Locator - Left Side & Rear View

Figure 4
Left Side View

1. Vent
2. DC-In Jack
3. HDMI-Out Port
4. Mini Display Port 1
5. Mini Display Port 2
6. USB 3.1 Gen 2 Type-C Ports
7. USB 3.0 (USB 3.1 Gen 1) Ports

LEFT SIDE VIEW



Figure 5
Rear View

1. Vent

REAR VIEW



External Locator - Bottom View



Figure 6
Bottom View

1. Vent
2. Sub Woofer

1. Introduction



Overheating

To prevent your computer from overheating, make sure nothing blocks any vent while the computer is in use.

Introduction

Figure 7
Mainboard Top
Key Parts

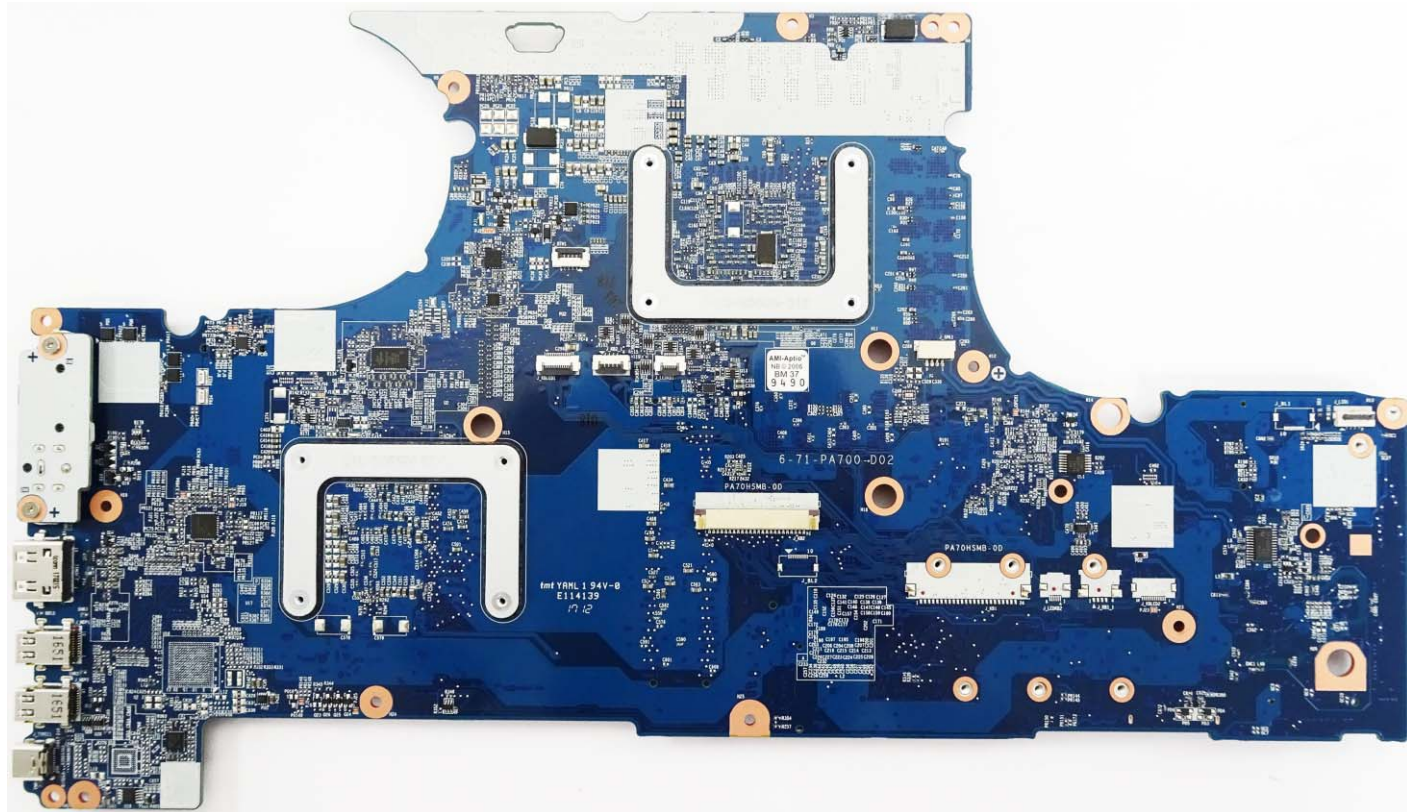
Mainboard Overview - Top (Key Parts)



Mainboard Overview - Bottom (Key Parts)

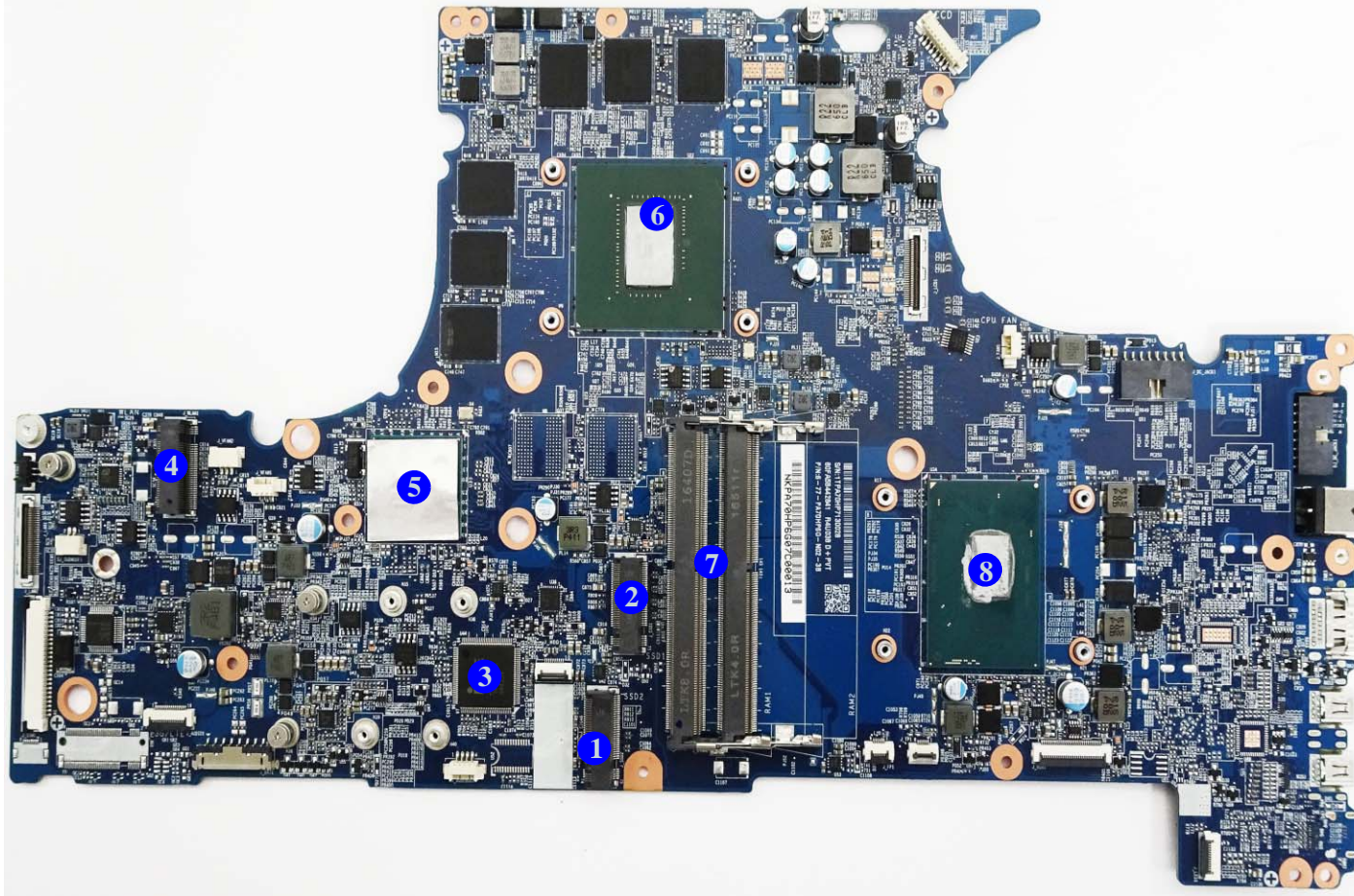

Figure 8
**Mainboard Bottom
Key Parts**

1. Mini-Card Connector (M.2 SSD Module)
2. Mini-Card Connector (M.2 SSD Module)
3. KBC-ITE IT8587
4. Mini-Card Connector (WLAN Module)
5. PCH
6. GPU-GTX1060
7. Memory Slots DDR4 SO-DIMM
8. CPU

Introduction

Figure 9
**Mainboard Top
Connectors**

1. HDMI Port
2. Mini Display Ports
3. USB 3.1 Gen 2
Type-C Port
4. Power Connector
5. RGB LED KB
Connector
6. RGB LED KB
Connector
7. White LED KB
Connector
8. Keyboard Cable
Connector
9. LID Connector

Mainboard Overview - Top (Connectors)

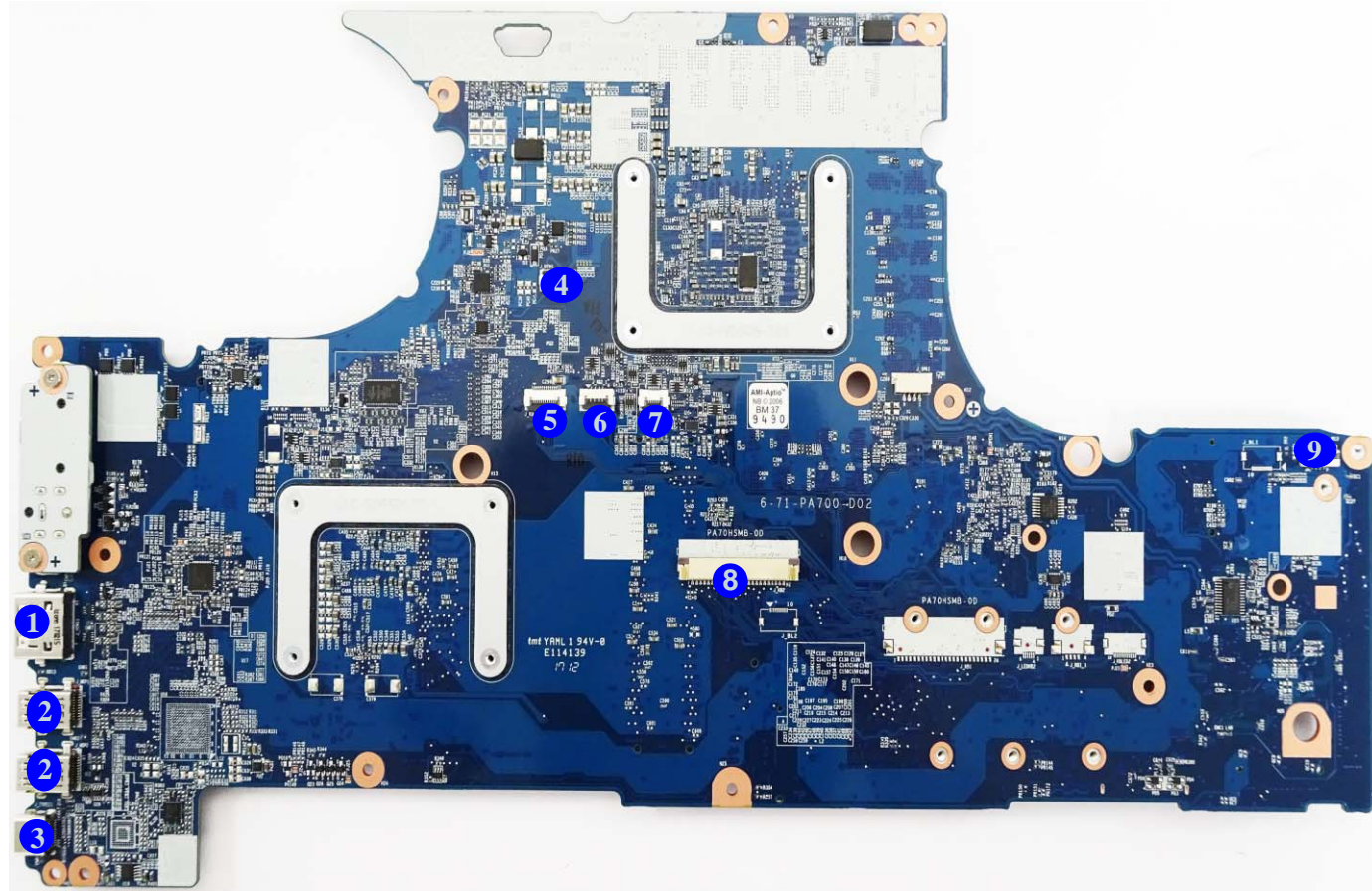

Mainboard Overview - Bottom (Connectors)

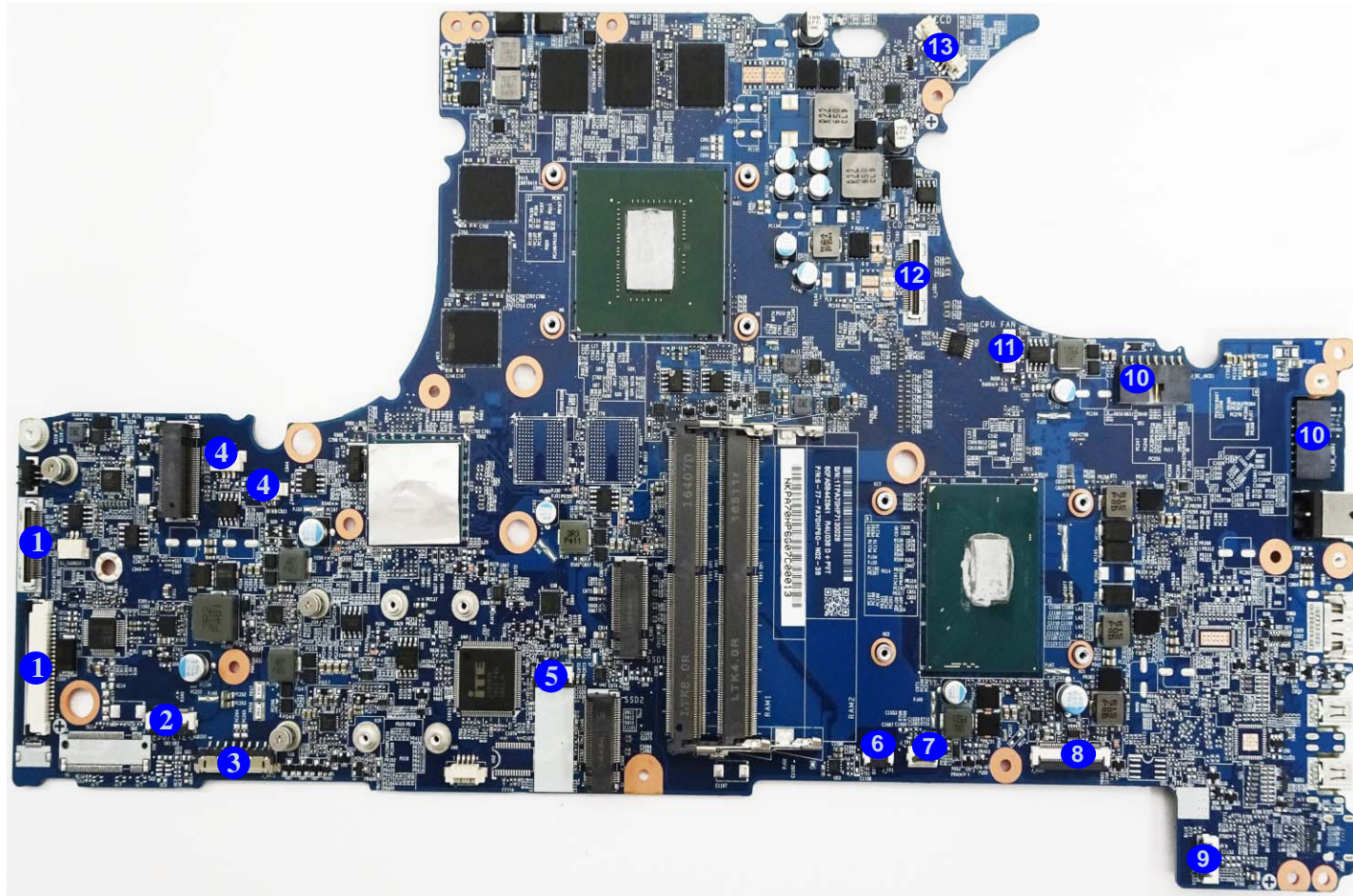

Figure 10
**Mainboard Bottom
Connectors**

1. Card Reader Board Connector
2. Audio Board Connector
3. Battery Connector
4. VGA Fan Connector
5. HDD Cable Connector
6. FP Cable Connector
7. Click Board Connector
8. USB Board Connector
9. LED Board Connector
10. DC Board Connector
11. CPU Fan Connector
12. LCD Connector
13. CCD Connector

Chapter 2: Disassembly



Overview

This chapter provides step-by-step instructions for disassembling the *PA70HP6(-G) / PA71HP6* series notebook's parts and subsystems. When it comes to reassembly, reverse the procedures (unless otherwise indicated).

We suggest you completely review any procedure before you take the computer apart.

Procedures such as upgrading/replacing the RAM, optical device and hard disk are included in the User's Manual but are repeated here for your convenience.

To make the disassembly process easier each section may have a box in the page margin. Information contained under the figure # will give a synopsis of the sequence of procedures involved in the disassembly procedure. A box with a  lists the relevant parts you will have after the disassembly process is complete. **Note:** The parts listed will be for the disassembly procedure listed ONLY, and not any previous disassembly step(s) required. Refer to the part list for the previous disassembly procedure. The amount of screws you should be left with will be listed here also.

A box with a  will also provide any possible helpful information. A box with a  contains warnings.

An example of these types of boxes are shown in the sidebar.

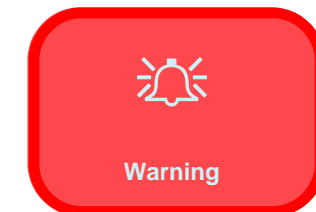
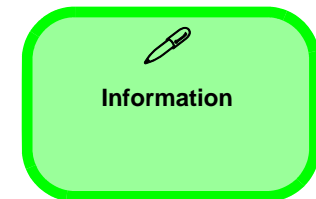

Disassembly

NOTE: All disassembly procedures assume that the system is turned **OFF**, and disconnected from any power supply (the battery is removed too).

Maintenance Tools

The following tools are recommended when working on the notebook PC:

- M3 Philips-head screwdriver
- M2.5 Philips-head screwdriver (magnetized)
- M2 Philips-head screwdriver
- Small flat-head screwdriver
- Pair of needle-nose pliers
- Anti-static wrist-strap

Connections

Connections within the computer are one of four types:

Locking collar sockets for ribbon connectors	To release these connectors, use a small flat-head screwdriver to gently pry the locking collar away from its base. When replacing the connection, make sure the connector is oriented in the same way. The pin1 side is usually not indicated.
Pressure sockets for multi-wire connectors	To release this connector type, grasp it at its head and gently rock it from side to side as you pull it out. Do not pull on the wires themselves. When replacing the connection, do not try to force it. The socket only fits one way.
Pressure sockets for ribbon connectors	To release these connectors, use a small pair of needle-nose pliers to gently lift the connector away from its socket. When replacing the connection, make sure the connector is oriented in the same way. The pin1 side is usually not indicated.
Board-to-board or multi-pin sockets	To separate the boards, gently rock them from side to side as you pull them apart. If the connection is very tight, use a small flat-head screwdriver - use just enough force to start.

Maintenance Precautions

The following precautions are a reminder. To avoid personal injury or damage to the computer while performing a removal and/or replacement job, take the following precautions:

1. **Don't drop it.** Perform your repairs and/or upgrades on a stable surface. If the computer falls, the case and other components could be damaged.
2. **Don't overheat it.** Note the proximity of any heating elements. Keep the computer out of direct sunlight.
3. **Avoid interference.** Note the proximity of any high capacity transformers, electric motors, and other strong magnetic fields. These can hinder proper performance and damage components and/or data. You should also monitor the position of magnetized tools (i.e. screwdrivers).
4. **Keep it dry.** This is an electrical appliance. If water or any other liquid gets into it, the computer could be badly damaged.
5. **Be careful with power.** Avoid accidental shocks, discharges or explosions.
 - Before removing or servicing any part from the computer, turn the computer off and detach any power supplies.
 - When you want to unplug the power cord or any cable/wire, be sure to disconnect it by the plug head. Do not pull on the wire.
6. **Peripherals** – Turn off and detach any peripherals.
7. **Beware of static discharge.** ICs, such as the CPU and main support chips, are vulnerable to static electricity. Before handling any part in the computer, discharge any static electricity inside the computer. When handling a printed circuit board, do not use gloves or other materials which allow static electricity buildup. We suggest that you use an anti-static wrist strap instead.
8. **Beware of corrosion.** As you perform your job, avoid touching any connector leads. Even the cleanest hands produce oils which can attract corrosive elements.
9. **Keep your work environment clean.** Tobacco smoke, dust or other air-borne particulate matter is often attracted to charged surfaces, reducing performance.
10. **Keep track of the components.** When removing or replacing any part, be careful not to leave small parts, such as screws, loose inside the computer.

Cleaning

Do not apply cleaner directly to the computer, use a soft clean cloth.

Do not use volatile (petroleum distillates) or abrasive cleaners on any part of the computer.

(For Computer Models Supplied with Light Blue Cleaning Cloth) Some computer models in this series come supplied with a light blue cleaning cloth. To clean the computer case with this cloth follow the instructions below.

- Power off the computer and peripherals.
- Disconnect the AC/DC adapter from the computer.
- Use a little water to dampen the cloth slightly.
- Clean the computer case with the cloth.
- Dry the computer with a dry cloth, or allow it time to dry before turning on.
- Reconnect the AC/DC adapter and turn the computer on.



Power Safety Warning

Before you undertake any upgrade procedures, make sure that you have turned off the power, and disconnected all peripherals and cables (including telephone lines and power cord). It is advisable to also remove your battery in order to prevent accidentally turning the machine on.

Disassembly Steps

The following table lists the disassembly steps, and on which page to find the related information. **PLEASE PERFORM THE DISASSEMBLY STEPS IN THE ORDER INDICATED.**

To remove the Keyboard:

1. Remove the keyboard [page 2 - 5](#)

To remove the Battery:

1. Remove the keyboard [page 2 - 5](#)
2. Remove the battery [page 2 - 6](#)

To remove the HDD:

1. Remove the keyboard [page 2 - 5](#)
2. Remove the battery [page 2 - 6](#)
3. Remove the HDD [page 2 - 8](#)

To remove the System Memory:

1. Remove the keyboard [page 2 - 5](#)
2. Remove the battery [page 2 - 6](#)
3. Remove the system memory [page 2 - 10](#)

To remove and install the M.2 SSD:

1. Remove the keyboard [page 2 - 5](#)
2. Remove the battery [page 2 - 6](#)
3. Remove the M.2 SSD-1 (Intel) [page 2 - 11](#)
4. Remove the M.2 SSD-1 [page 2 - 12](#)
5. Remove the M.2 SSD-2 [page 2 - 13](#)

To remove the Wireless LAN Module:

1. Remove the keyboard [page 2 - 5](#)
2. Remove the battery [page 2 - 6](#)
3. Remove the WLAN [page 2 - 14](#)

To remove the CCD Module:

1. Remove the keyboard [page 2 - 5](#)
2. Remove the battery [page 2 - 6](#)
3. Remove the CCD module [page 2 - 16](#)

To remove the LCD Module:

1. Remove the keyboard [page 2 - 5](#)
2. Remove the battery [page 2 - 6](#)
3. Remove the HDD [page 2 - 8](#)
4. Remove the system memory [page 2 - 10](#)
5. Remove the M.2 SSD [page 2 - 11](#)
6. Remove the WLAN [page 2 - 14](#)
7. Remove the LCD module [page 2 - 18](#)

Removing the Keyboard

1. Turn **off** the computer, turn it over.
2. Remove screws **1** - **2** from the bottom of the computer.
3. Open it up with the LCD on a flat surface before pressing at point **3** to release the keyboard module (use the special eject stick **4** to do this) while releasing the keyboard in the direction of the arrow **5** as shown (*Figure 1a*).
4. Carefully lift the keyboard **6** up, being careful not to bend the keyboard ribbon cable **7**. Disconnect the keyboard ribbon cable **7** from the locking collar socket by using a flat-head screwdriver to pry the locking collar pins **8** away from the base (*Figure 1b*).
5. Carefully lift the keyboard **6** off the computer (*Figure 1c*).

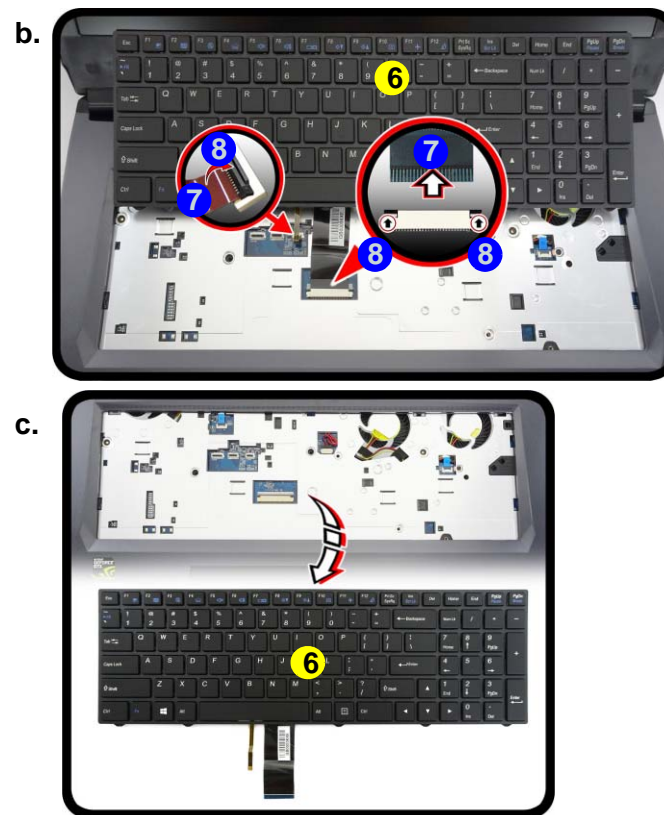
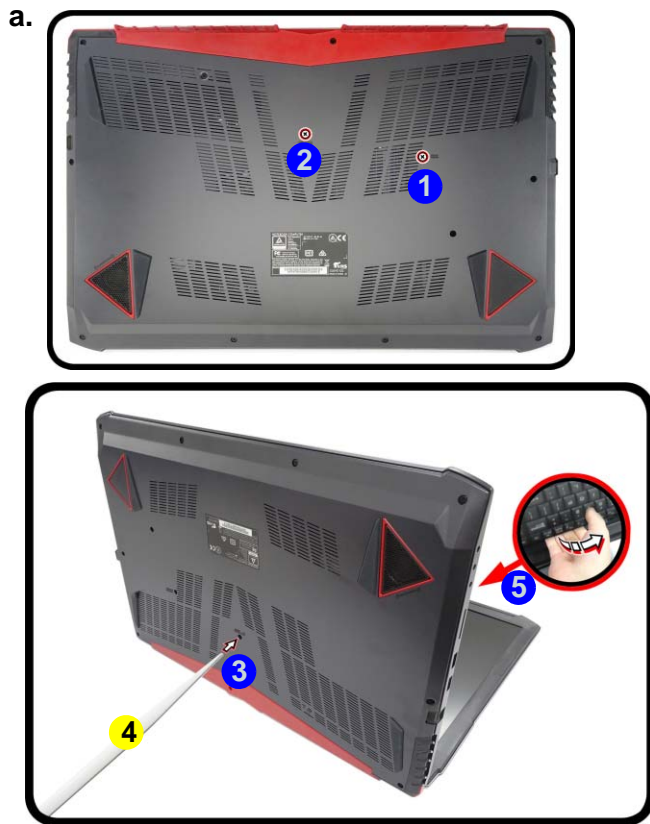

Figure 1
Keyboard Removal

- a. Remove the screws from the bottom of the computer and then eject the keyboard using a special eject stick to push the keyboard out while releasing the keyboard as shown.
- b. Lift the keyboard up and disconnect the keyboard ribbon cable from the locking collar socket.
- c. Remove the keyboard.



Re-inserting the Keyboard

When re-inserting the keyboard firstly, align the keyboard tabs at the bottom of the keyboard with the slots in the case.



4. Eject Stick
6. Keyboard

- 2 Screws

Disassembly

Figure 2
Battery Removal

- Remove the screws.
- Remove the SD card cover and screws.
- Remove the bottom case.

Removing the Battery

- Turn the computer off, and remove the keyboard ([page 2 - 5](#)).
- Remove screw ① ([Figure 2a](#)).
- Remove the SD card cover ② and screws ③ - ⑬ ([Figure 2b](#)).
- Release the bottom case ⑭ by using the left thumb ⑮ to hold down the most prominent area of the back cover and then use the right hand ⑯ to lift the rear side vent's most prominent area ([Figure 2c](#)).
- Carefully remove the bottom case up in the direction of the arrow ⑰.

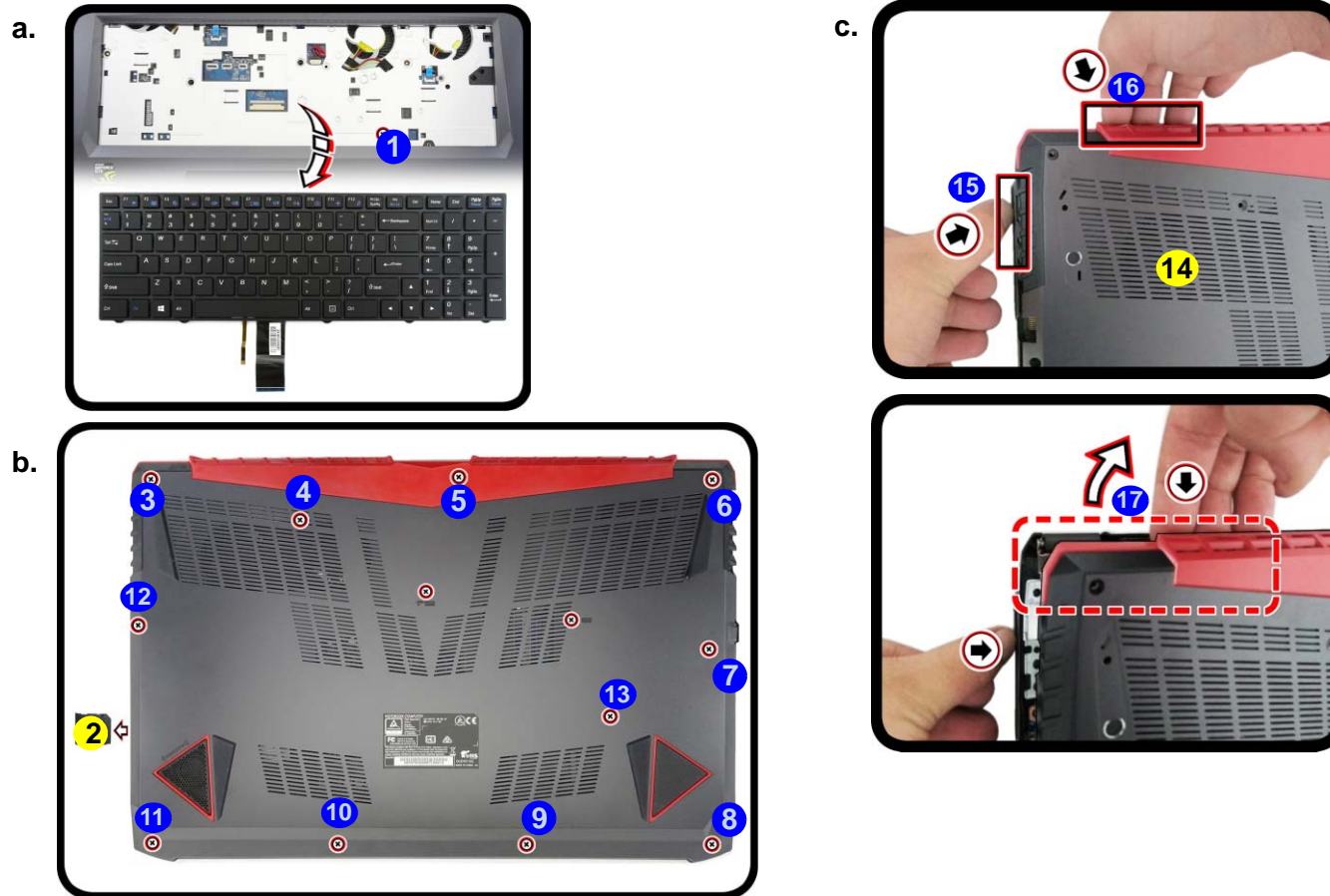

②. SD Card Cover
⑭. Bottom Case

- 12 Screws

- The battery will be visible at point **18** on the computer (*Figure 3d*).
- Carefully disconnect the cable **19**, then remove screws **20** - **23** (*Figure 3e*).
- Lift the battery **24** off the computer (*Figure 3f*).
- Reverse the process to install a new battery (do not forget to replace all the screws and bottom cover).

d.



f.



e.



- Locate the battery.
- Disconnect the cable and remove the screws.
- Lift the battery off the computer.

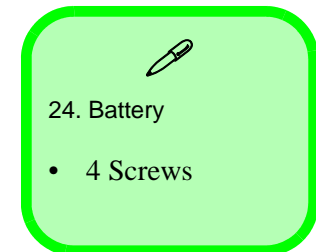

Figure 4
**HDD Assembly
Removal**

- a. Locate the HDD.
- b. Remove the screws.

Removing the Hard Disk Drive

The hard disk drive can be taken out to accommodate other 2.5" serial (SATA) hard disk drives with a height of 7mm (h). Follow your operating system's installation instructions, and install all necessary drivers and utilities (as outlined in **Chapter 4 of the User's Manual**) when setting up a new hard disk.

Hard Disk Disassembly Process

1. Turn **off** the computer, and remove the keyboard ([page 2 - 5](#)) and battery ([page 2 - 6](#)).
2. The HDD will be visible at point **1** on the mainboard ([Figure 4a](#)).
3. Remove the screw **2** from the HDD assembly ([Figure 4b](#)).

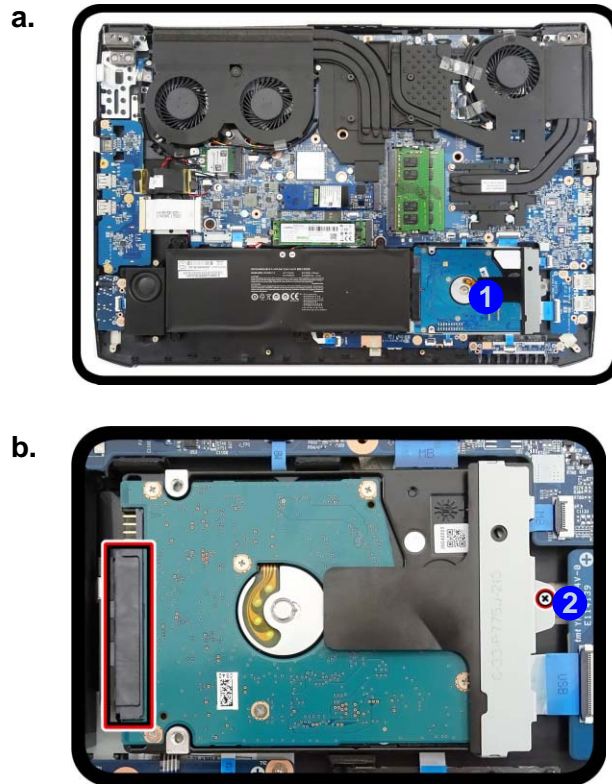

HDD System Warning

New HDD's are blank. Before you begin make sure:

You have backed up any data you want to keep from your old HDD.

You have all the CD-ROMs and FDDs required to install your operating system and programs.

If you have access to the internet, download the latest application and hardware driver updates for the operating system you plan to install. Copy these to a removable medium.



6. Hard Disk

- 1 Screw

4. Slightly slide and pull the hard disk out.
5. Lift the hard disk assembly **3** out of the bay **4** (*Figure 5c*).
6. Remove screws **5** - **6** and bracket **7** from the hard disk **8** (*Figure 5d*).
7. Reverse the process to install a new hard disk (do not forget to replace the screws).

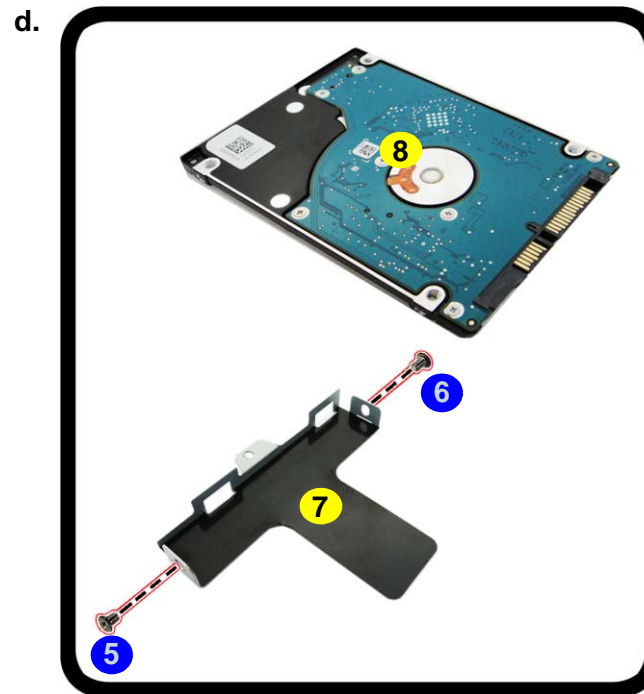
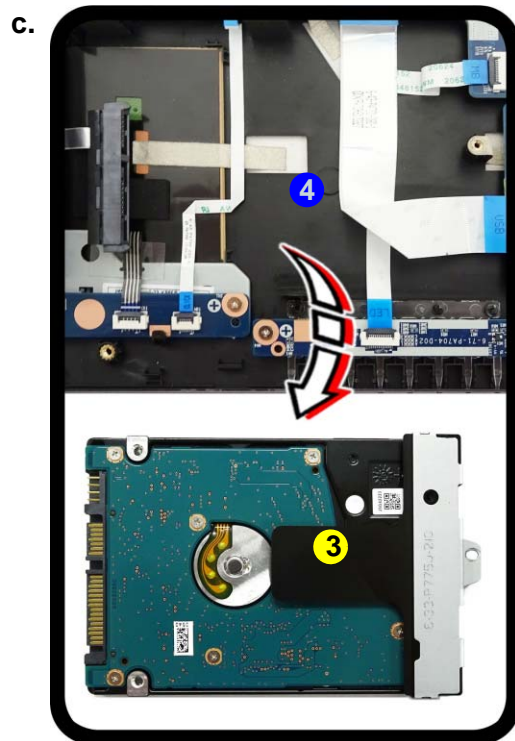

- c. Slide and pull the HDD assembly out of the bay.
- d. Remove the screws and bracket from the HDD.

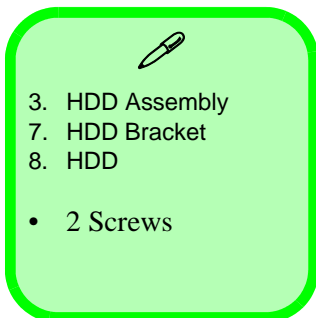

Figure 6
RAM Module Removal

- The RAM modules will be visible at point **1** on the mainboard.
- Pull the release latches.
- Remove the module.



Contact Warning

Be careful not to touch the metal pins on the module's connecting edge. Even the cleanest hands have oils which can attract particles, and degrade the module's performance.



4. RAM Module

Removing the System Memory (RAM)

The computer has four memory sockets for 260 pin Small Outline Dual In-line Memory Modules (SO-DIMM) supporting DDR4 Up to 2400 MHz. The main memory can be expanded up to 64GB. The total memory size is automatically detected by the POST routine once you turn on your computer.

Memory Upgrade Process

- Turn **off** the computer, turn it over, remove the keyboard ([page 2 - 5](#)) and battery ([page 2 - 6](#)).
- The RAM-2 modules will be visible at point **1** on the mainboard ([Figure 6a](#)).
- Gently pull the two release latches (**2** & **3**) on the sides of the memory socket in the direction indicated by the arrows ([Figure 6b](#)). The RAM module **4** will pop-up ([Figure 6c](#)), and you can then remove it.
- Pull the latches to release the second module if necessary.
- Insert a new module holding it at about a 30° angle and fit the connectors firmly into the memory slot.
- The module will only fit one way as defined by its pin alignment. Make sure the module is seated as far into the slot as it will go. **DO NOT FORCE IT**; it should fit without much pressure.
- Press the module in and down towards the mainboard until the slot levers click into place to secure the module.
- Replace the bottom cover and the screws (see [page 2 - 6](#)).
- Restart the computer to allow the BIOS to register the new memory configuration as it starts up.

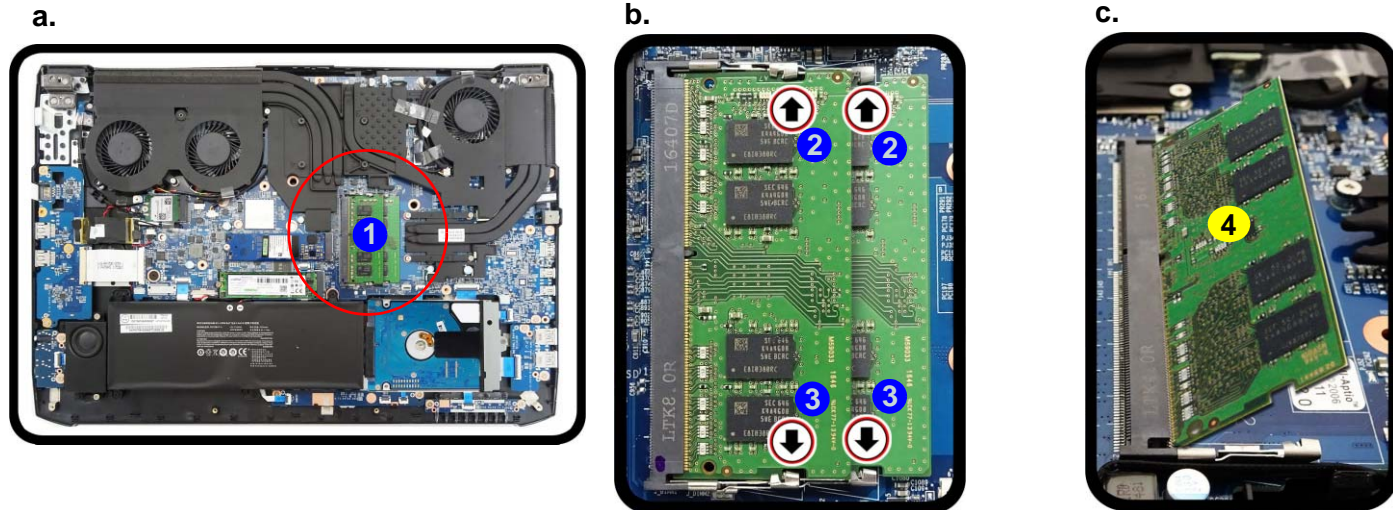

Removing the M.2 SSD Module

M.2 SSD-1 (Intel Optane) Removal Procedure

1. Turn **off** the computer, turn it over, remove the keyboard ([page 2 - 5](#)) and battery ([page 2 - 6](#)).
2. The M.2 SSD module will be visible at point **1** on the mainboard ([Figure 7a](#)).
3. Remove the screw **2** ([Figure 7b](#)).
4. The M.2 SSD module **3** ([Figure 7c](#)) will pop-up, and you can remove it from the computer.
5. Reverse the process to install a new module (do not forget to replace the screws and thermal pad).

Figure 7
M.2 SSD-1 Module Removal

- a. Locate the M.2 SSD.
- b. Remove the screw.
- c. The M.2 SSD module will pop up.

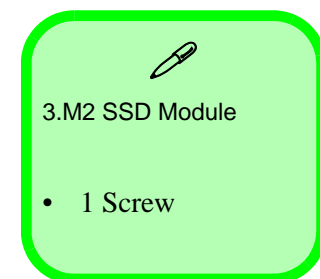
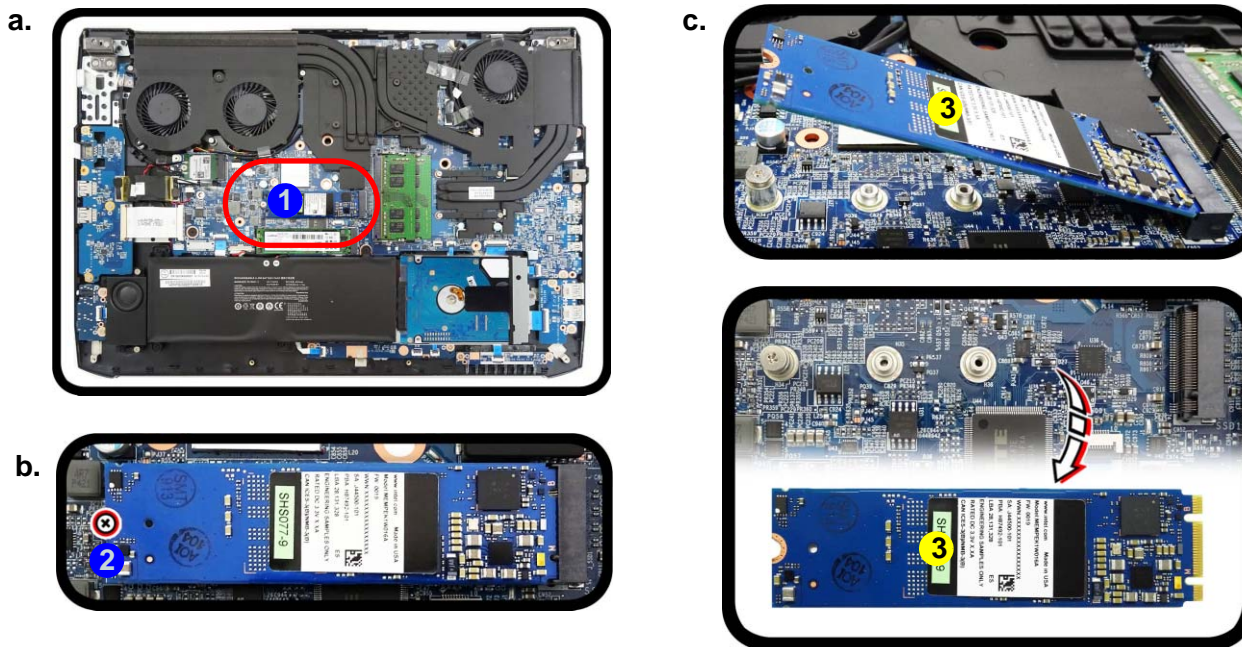

Disassembly

Figure 8
M.2 SSD-1 Module Removal

- Locate the M.2 SSD.
- Remove the screw.
- The M.2 SSD module will pop up.

M.2 SSD-1 Removal Procedure

- Turn off the computer, turn it over, remove the keyboard ([page 2 - 5](#)) and battery ([page 2 - 6](#)).
- The M.2 SSD module will be visible at point **1** on the mainboard ([Figure 7a](#)).
- Remove the screw **2** ([Figure 7b](#)).
- The M.2 SSD module **3** ([Figure 7c](#)) will pop-up, and you can remove it from the computer.
- Reverse the process to install a new module (do not forget to replace the screws and thermal pad).

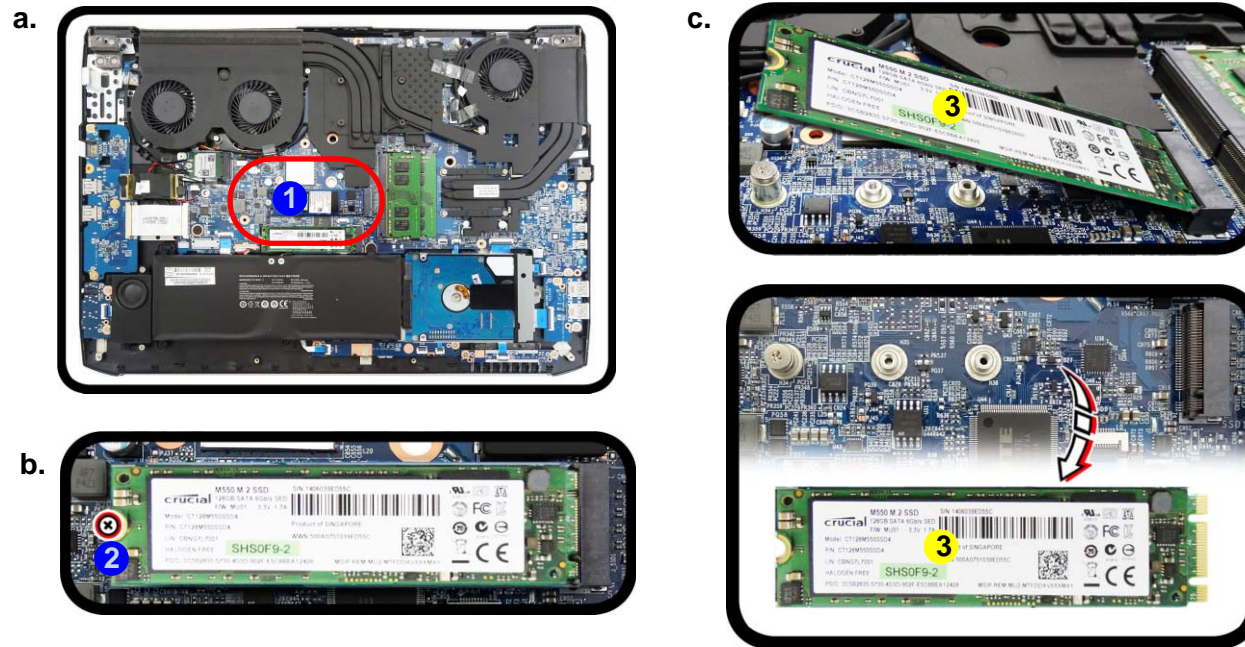

3.M2 SSD Module

- 1 Screw

M.2 SSD-2 Removal Procedure

1. Turn off the computer, turn it over, remove the keyboard ([page 2 - 5](#)) and battery ([page 2 - 6](#)).
2. The M.2 SSD module will be visible at point **1** on the mainboard ([Figure 7a](#)).
3. Remove the screw **2** ([Figure 7b](#)).
4. The M.2 SSD module **3** ([Figure 7c](#)) will pop-up, and you can remove it from the computer.
5. Reverse the process to install a new module (do not forget to replace the screws and thermal pad).

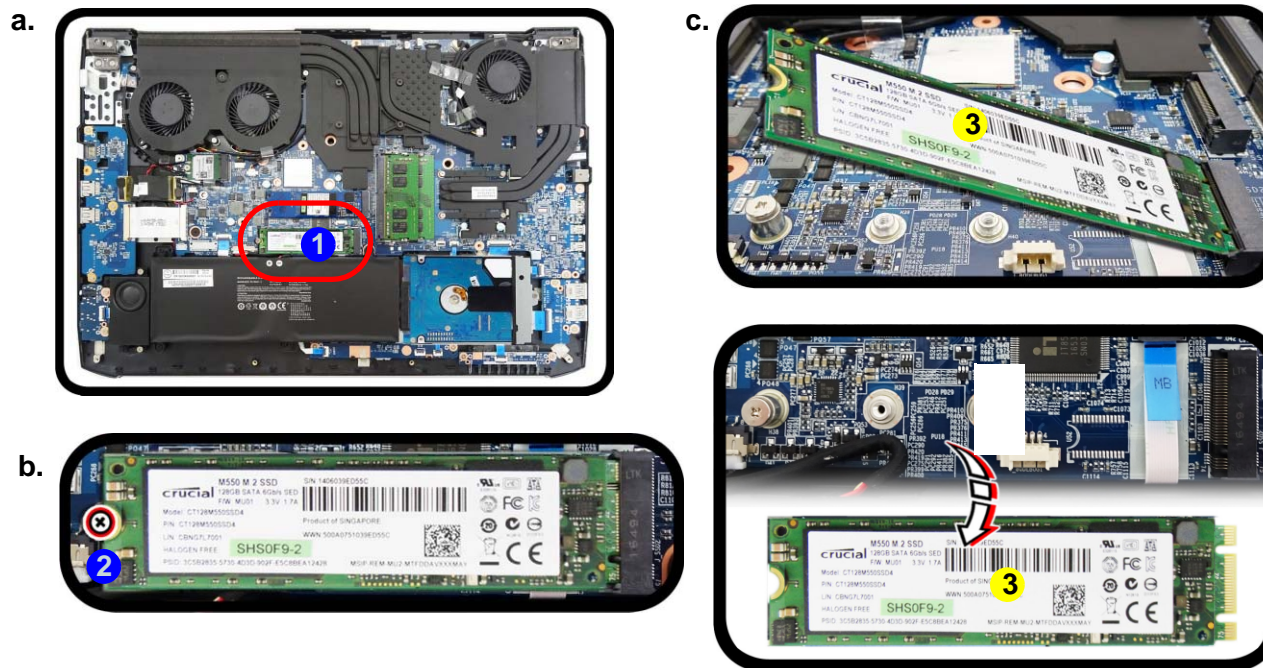

- Figure 9*
M.2 SSD-2 Module Removal
- Locate the M.2 SSD.
 - Remove the screw.
 - The M.2 SSD module will pop up.

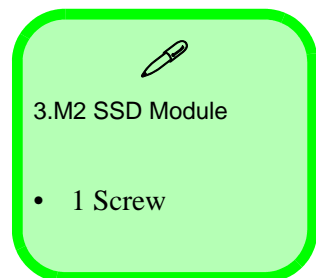

Disassembly

Figure 10
**Wireless LAN
 Module Removal**

- Locate the WLAN.
- Disconnect the cables **2** and remove the screw **4**.
- The WLAN module will pop up.

Note: Make sure you reconnect the antenna cable to the “1 + 2” socket (*Figure 10b*).

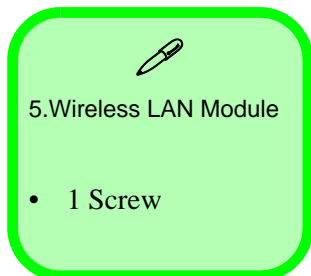

Removing the Wireless LAN Module

- Turn **off** the computer, turn it over, remove the keyboard (*page 2 - 5*) and battery (*page 2 - 6*).
- The Wireless LAN module will be visible at point **1** on the mainboard (*Figure 10a*).
- Carefully disconnect the cables **2** & **3**, and then remove the screw **4** (*Figure 10b*).
- The Wireless LAN module **5** (*Figure 10c*) will pop-up, and you can remove it from the computer.

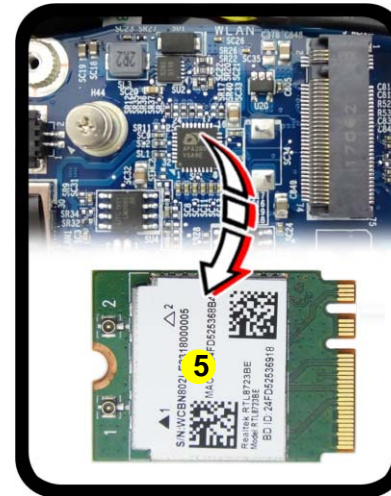
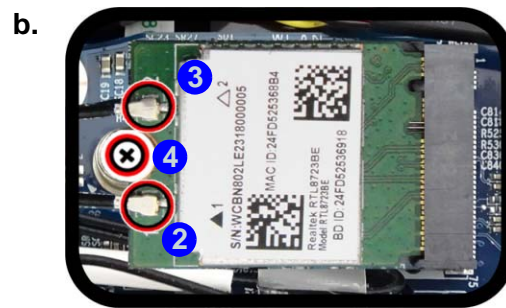
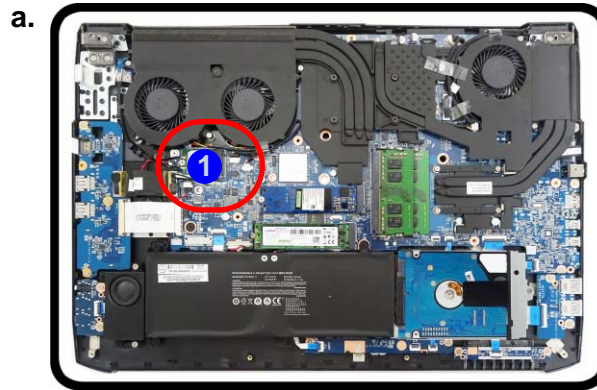

Wireless LAN, Combo Module Cables

Note that the cables for connecting to the antennae on WLAN, WLAN & Bluetooth Combo, and LTE modules are not labelled. The cables/covers (each cable will have either a black or transparent cable cover) are color coded for identification as outlined in the table below.

Module Type	Antenna Type	Cable Color	Cable Cover Type
WLAN/WLAN & Bluetooth Combo	WM 1	Black	Transparent
	WM 2	Black	White

Cable 1 is usually connected to antenna 1 (Main) on the module, and cable 2 to antenna 2 (Aux).

Disassembly

Figure 11
CCD Removal

- a. Remove rubber and screws and then carefully release the inner frame of the LCD panel at the points indicated by the arrows.
- b. Remove the LCD front cover.

Removing the CCD

1. Turn **off** the computer, turn it over to remove the keyboard ([page 2 - 5](#)) and battery ([page 2 - 6](#)).
2. Lay the computer down on a flat surface with the top case up forming a 120 degree angle. Carefully remove the mylar covers **1** - **2** and screws **3** - **4**.
3. Run your fingers around the inner frame of the LCD panel to lift it up at points **5** - **6** as indicated by the arrows, run your fingers again around the inner frame at point **7** to lift from one corner to the other as indicated by the arrows, and then lift up the outer frame at point **8** as indicated by the arrows ([Figure 11e](#)).
4. Remove the LCD front cover **5** ([Figure 11b](#)).

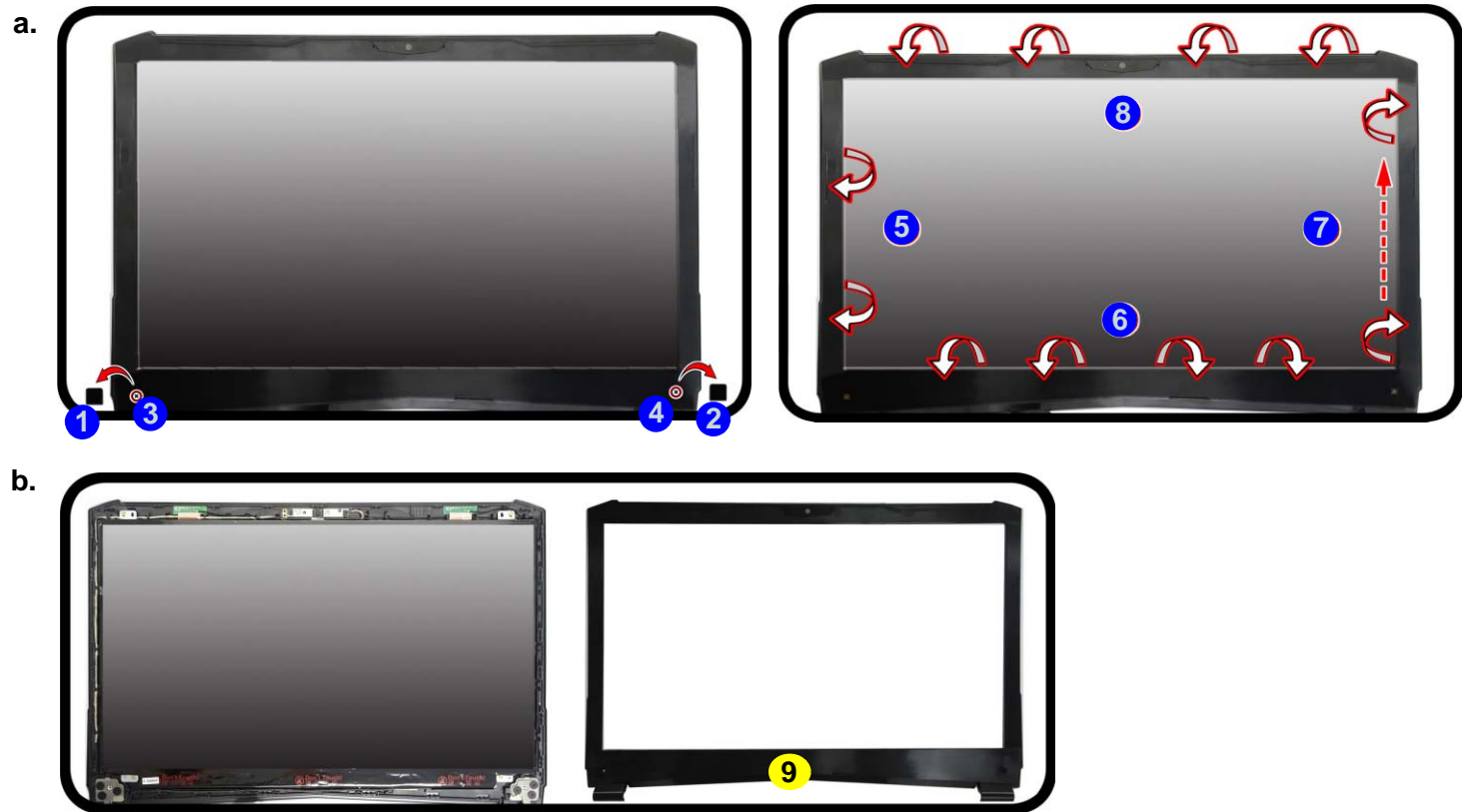

5. Disconnect the cable **10** (*Figure 12c*).
6. Remove the CCD module **11** (*Figure 12d*).
7. Reverse the process to install a new CCD module.

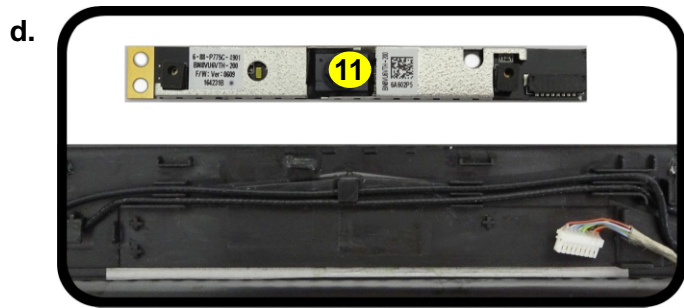
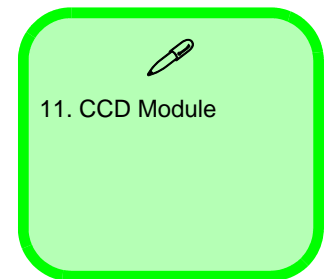

Figure 12
CCD Removal
(cont'd)

- c. Disconnect the cable.
- d. Remove the CCD module.



Disassembly

Figure 13

Top Case Removal

- a. Remove screws and heatsink then carefully release the inner frame of the LCD panel at the points indicated by the arrows.
- b. Remove the LCD front cover.

Removing the LCD Module

1. Turn **off** the computer, turn it over to remove the keyboard ([page 2 - 5](#)), battery ([page 2 - 6](#)), HDD ([page 2 - 8](#)), RAM ([page 2 - 10](#)), SSD module ([page 2 - 11](#)) and WLAN ([page 2 - 14](#)).
2. Lay the panel down on a flat surface (protection pad) with the top case open forming a 120 degree angle. Carefully disconnect the cables **1** - **4** and remove the screws **5** - **18** ([Figure 13a](#)).
3. Lift and remove the heatsink **19** from the mainboard ([Figure 13b](#)).

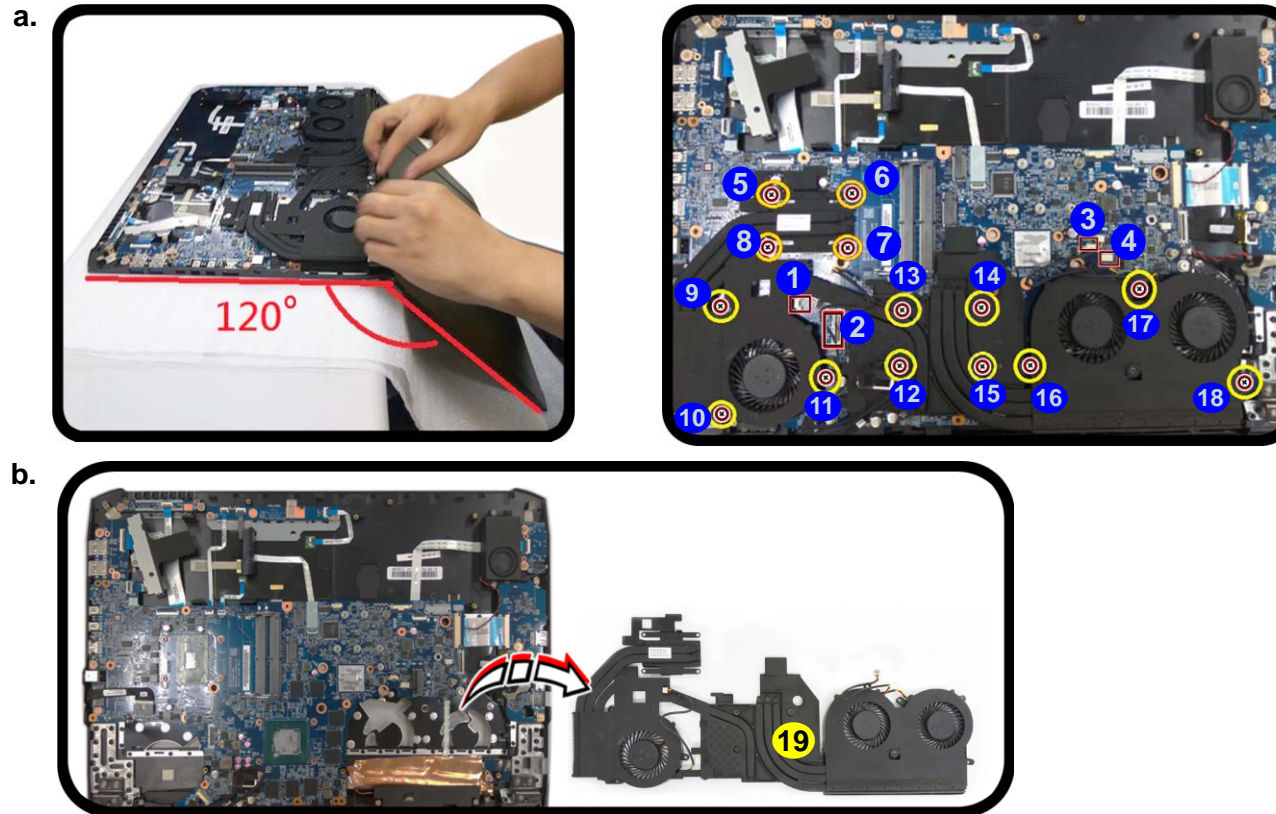

19. Heat sink

- 14 Screws

- Remove the screws 20 - 21 from the hinge cover and the screws 22 - 27 from the hinge (Figure 14c).
- Remove the LCD module 28 while it is open, still forming a 120 degree angle (Figure 14d).
- Reverse the process to install a new LCD module.

Figure 14
Top Case Removal
(cont'd)

- Remove the screws.
- Remove the LCD module.

c.

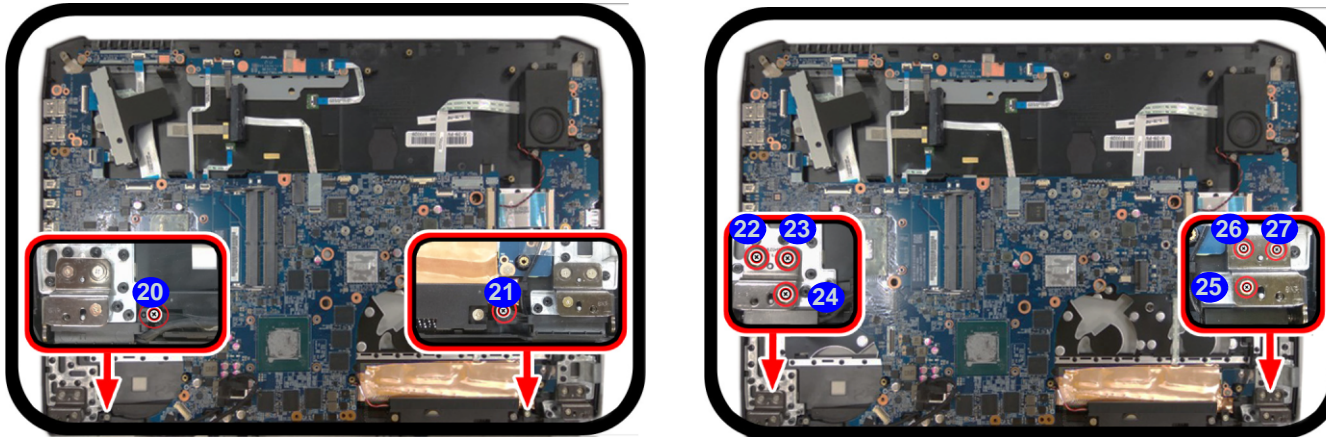

d.

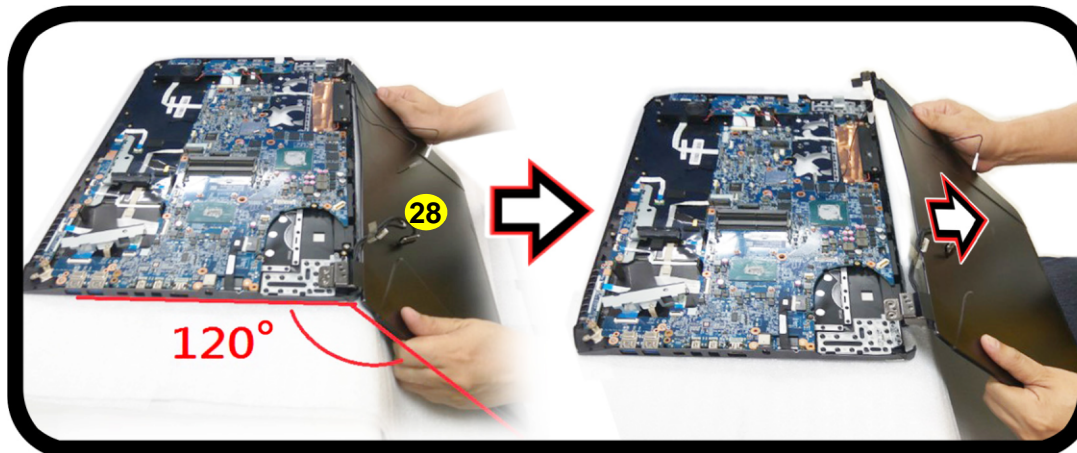



28. LCD Module

- 8 Screws

Disassembly

Figure 15
**LCD Module
Removal**

- e. Remove rubber and screws and then carefully release the inner frame of the LCD panel at the points indicated by the arrows.
- f. Remove the LCD front cover.

7. Lay the LCD module down on a flat surface. Carefully remove the mylar covers **29** - **30** and screws **31** - **32**.
8. Run your fingers around the inner frame of the LCD panel to lift it up at points **33** - **34** as indicated by the arrows, run your fingers again around the inner frame at point **35** to lift from one corner to the other as indicated by the arrows and then lift up the outer frame at point **36** as indicated by the arrows (*Figure 15e*).
9. Remove the LCD front cover **37** (*Figure 15f*).

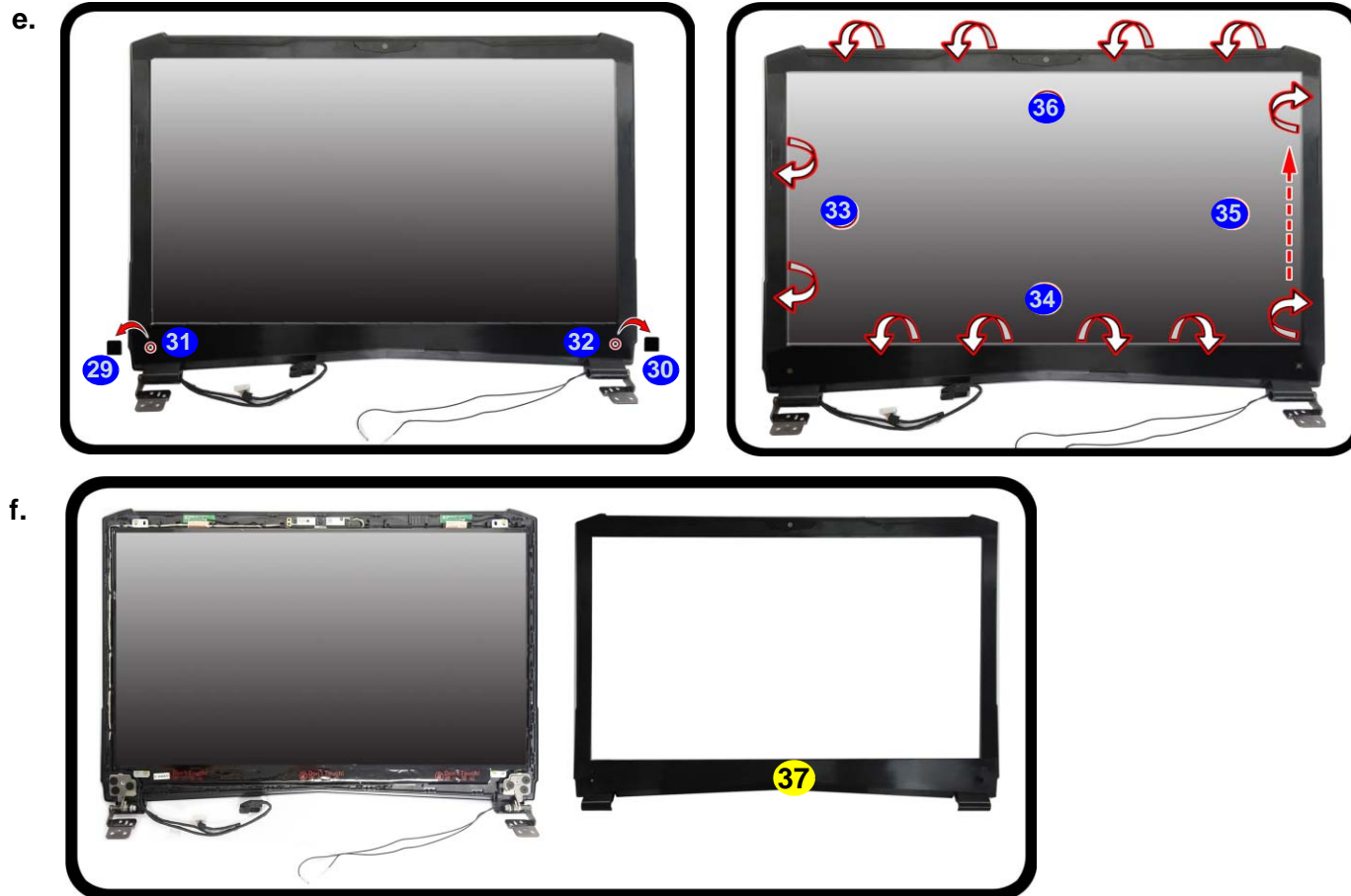

37. LCD Front Cover

- 2 Screws

Disassembly

10. Remove the screws 38 - 41 (Figure 12c).
11. Remove the LCD panel 42 (Figure 16b).
12. Reverse the process to install a new LCD panel.



Figure 16
**LCD Module
Removal (cont'd)**

- g. Remove the screws.
- h. Remove the LCD panel.



42. LCD Panel

- 4 Screws

Appendix A:Part Lists

This appendix breaks down the *PA70HP6(-G) / PA71HP6* series notebook's construction into a series of illustrations. The component part numbers are indicated in the tables opposite the drawings.

Note: This section indicates the *manufacturer's* part numbers. Your organization may use a different system, so be sure to cross-check any relevant documentation.

Note: Some assemblies may have parts in common (especially screws). However, the part lists DO NOT indicate the total number of duplicated parts used.

Note: Be sure to check any update notices. The parts shown in these illustrations are appropriate for the system at the time of publication. Over the product life, some parts may be improved or re-configured, resulting in *new* part numbers.

Part List Illustration Location

The following table indicates where to find the appropriate part list illustration.

Table A - 1
**Part List Illustration
Location**

Part	
Top	<i>page A - 3</i>
Bottom	<i>page A - 4</i>
Main Board	<i>page A - 5</i>
HDD	<i>page A - 6</i>
LCD	<i>page A - 7</i>

Top

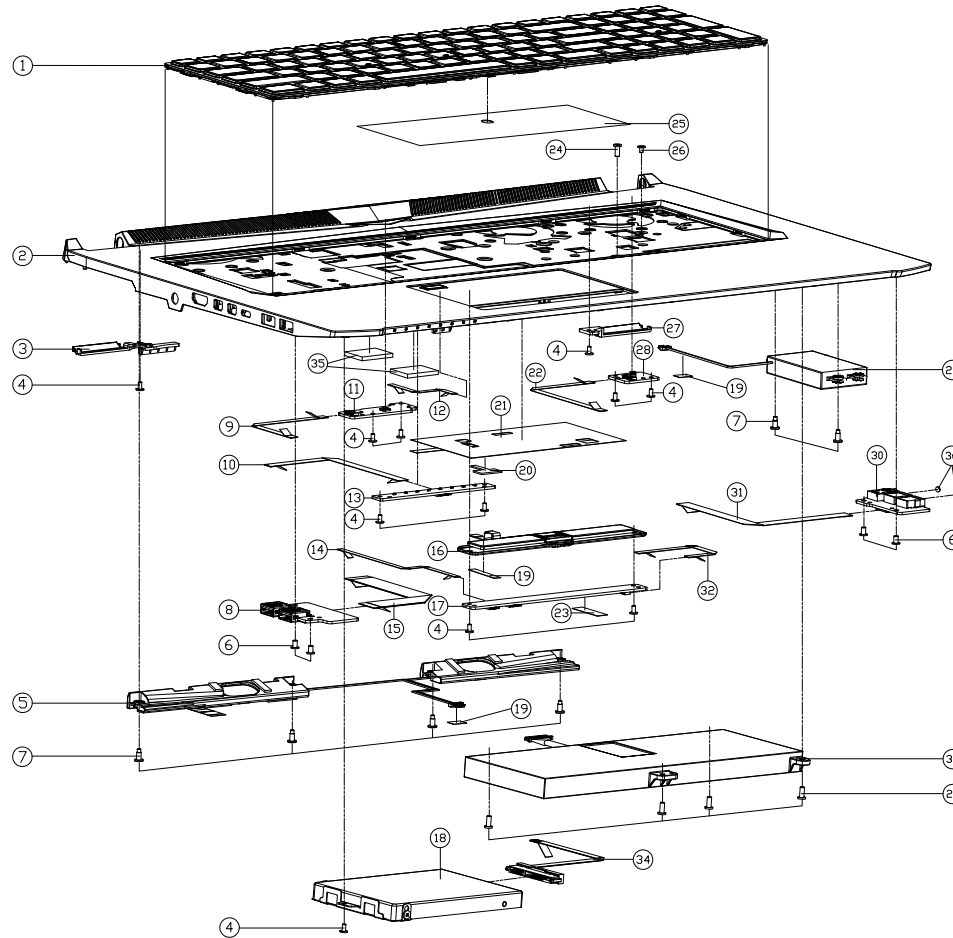

ITEM	PART NAME	PART NO	REMARK
1	NYLON GRID (25*25) BLACK FOR TOP COVER (100*100*1.5) (100*100*1.5)	6-80-N8500-011-1	
1	NYLON GRID (25*25) BLACK FOR TOP COVER (100*100*1.5) (100*100*1.5)	6-80-N7500-012-1	
2	OPRE-PROCESS TOP CASE MODULE (W/D FP) PA70HS	6-78-PA70HS02-010	
2	OPRE-PROCESS TOP CASE MODULE (W/FP) PA70HS	6-78-PA70HS02-020	
2	OPRE-PROCESS TOP CASE MODULE (W/D FP) PA70HS	6-78-PA71HS02-010	
2	OPRE-PROCESS TOP CASE MODULE (W/FP) PA70HS	6-78-PA71HS02-020	
3	HINGE COVER-L(PC+ABS) PA70HS	6-42-PA702-022	
3	HINGE COVER-L(PC+ABS) PA71HS	6-42-PA712-021	
4	SCREW M2*4L KI NI ICT NY (00-#4.5,DT-0.4)	6-35-B1120-4RE	
5	SPK+CABLE RLL R 97.5MM L 115.5MM 2V 4T PA70HS	6-23-5PA70-0S3	
6	SCREW M2.5*4L KI NI ICT NY	6-35-21125-4R0	
7	SCREW M2*6.2L NI ICT NY FOR SPEAKER	6-35-Z1120-6R2	
8	USB3.0 BOARD/W/REDRIVER V2.0 PA70HS	6-77-PA703-D02	
8	USB3.0 BOARD V2.0A PA70HS	6-77-PA703-D12A	
9	FFC CABLE POWER TO MB (P-110) 4 PIN (L-98) MPA70HS	6-43-PA700-012	
10	FFC CABLE LED TO MB (P-45) 12 PIN (L-185) MPA70HS	6-43-PA700-032	
11	POWER SWITCH BOARD V2.0A PA70HS	6-77-PA705-D02A	
12	FFC CABLE TRFP TO MB (P-45) 4 PIN (L-57) MPA70HS	6-43-PA700-052	ONLY FOR W/FINGER
13	LED BOARD V2.0A PA70HS	6-77-PA704-D02A	
14	FFC CABLE CLICK TO MB (P-45) 6 PIN (L-183) MPA70HS	6-43-PA700-022	
15	FFC CABLE USB TO MB (P-45) 30 PIN (L-116) MPA70HS	6-43-PA700-082	
16	FUNCTION KEY FOR CLICK BUTTON MODULE W/O FINGER (P-60)	6-23-KPA70-010	FOR PA70HS/HP6-/G
16	FUNCTION KEY FOR CLICK BUTTON MODULE W/O FINGER (P-60)	6-23-KP65R-022	FOR PA70HS/HP6-/G
17	CLICK BOARD V2.0A PA70HS	6-77-PA702-D02A	
18	W/D HDD ASS'Y PA70HS	6-79-PA70HSJ-010	
18	W/HDD ASS'Y PA70HS	6-79-PA70HSJ-020	
19	TAPE MYLAR TRANSPARENT (20*10*0.05) P160MM	6-40-P1803-020	
20	SPONGE(25*25) FOR 7 MM HDD PA70HS	6-47-0019A-25D	ONLY FOR 7MM HDD
21	MYLAR FOR TOUCHPAD(108*46) PA70HS	6-40-PA702-012	
22	FFC CABLE HALL SENSOR TO MB (P-110) 4 PIN (L-85) MPA70HS	6-43-PA700-062	
23	CONDUCTIVE CLOTH -B PA70HS	6-47-PA702-050	
24	SCREW M2.5*6L K BZ ICT NY	6-35-82125-6RA	
25	BACKLIGHT KB THERMAL(0.8*1.4) AL FILL(0.6*1) NS306	6-47-N5507-010	
26	SCREW M2*3L KI BZ ICT NY (00-#4.5,DT-0.4)	6-35-B6120-3RD	
27	HINGE COVER-R(PC+ABS) PA70HS	6-42-PA702-012	
27	HINGE COVER-R(PC+ABS) PA71HS	6-42-PA712-011	
28	LID BOARD V2.0A PA70HS	6-77-PA706-D02A	
29	SPK+CABLE SUBWOOFER 55*32 107MM 40W 4T PA70HS	6-23-5PA70-0W1	
30	AUDIO BOARD V2.0A PA70HS	6-77-PA708-D02A	
31	FFC CABLE AUDIO TO MB (P-45) 16 PIN (L-170) MPA70HS	6-43-PA700-042	
32	FFC CABLE TP TO CLICK (P-45) 8 PIN (L-83) MPA70HS	6-43-PA700-092	
33	NYLON SPRING FOR TOUCHPAD (108*46) (108*46*1.5) (108*46*1.5)	6-87-PA705-61B01	
33	NYLON SPRING FOR TOUCHPAD (108*46) (108*46*1.5) (108*46*1.5)	6-87-PA705-62B01	
34	HDD CONDUCTIVE CABLE CODE FFC CABLE (22.5*40) (22.5*40)	6-23-FPA70-011	
35	SPONGE(25*25) FOR 7 MM HDD PA70HS	6-47-0019A-25F	
36	MYLAR (0.3*0.5) BLACK FOR PA70HS	6-40-PA702-0A0	

Figure A - 1
Top

Bottom

Figure A - 2
Bottom

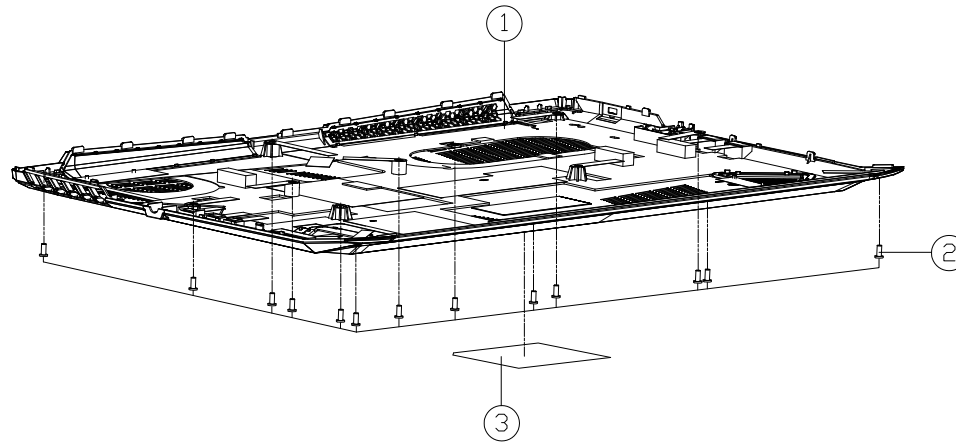

ITEM	PART NAME	PART NO	REMARK
1	BOTTOM CASE MODULE PA70HS	6-39-PA703-012	
1	BOTTOM CASE MODULE PA71HS	6-39-PA713-011	
1	BOTTOM CASE MODULE PA70HS-GM	6-39-PA703-011-M	
2	SCREW M2.5*6L K BZ ICT NY	6-35-B2125-6RA	
3	PRODUCT LABEL FOR PA70HS	6-45-PA70HS03-010	
3	PRODUCT LABEL FOR PA70HS-G	6-45-PA70HSG3-010	
3	PRODUCT LABEL FOR PA70HP6	6-45-PA70HP63-010	
3	PRODUCT LABEL FOR PA70HP6-G	6-45-PA70HP6G-010	
3	PRODUCT LABEL FOR PA71HS	6-45-PA71HS03-010	
3	PRODUCT LABEL FOR PA71HP6	6-45-PA71HP63-010	
3	PRODUCT LABEL FOR PA71HS-G	6-45-PA71HSG3-010	
3	PRODUCT LABEL FOR PA71HP6-G	6-45-PA71HP6G-010	
3	PRODUCT LABEL MEDIUM ERASER X785X FOR PA70HS-GM	6-45-PA70HSGM-010	
3	PRODUCT LABEL MEDIUM ERASER X785X FOR PA70HP6-GM	6-45-PA70HP6GM-010	

HDD

Figure A - 4
HDD

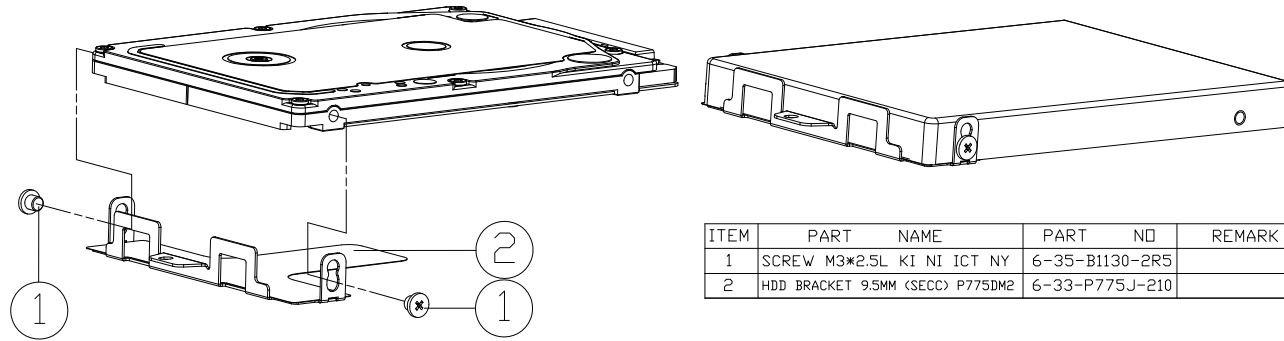

ITEM	PART NAME	PART NO	REMARK
1	SCREW M3*2.5L KI NI ICT NY	6-35-B1130-2R5	
2	HDD BRACKET 9.5MM (SECC) P775DM2	6-33-P775J-210	

LCD

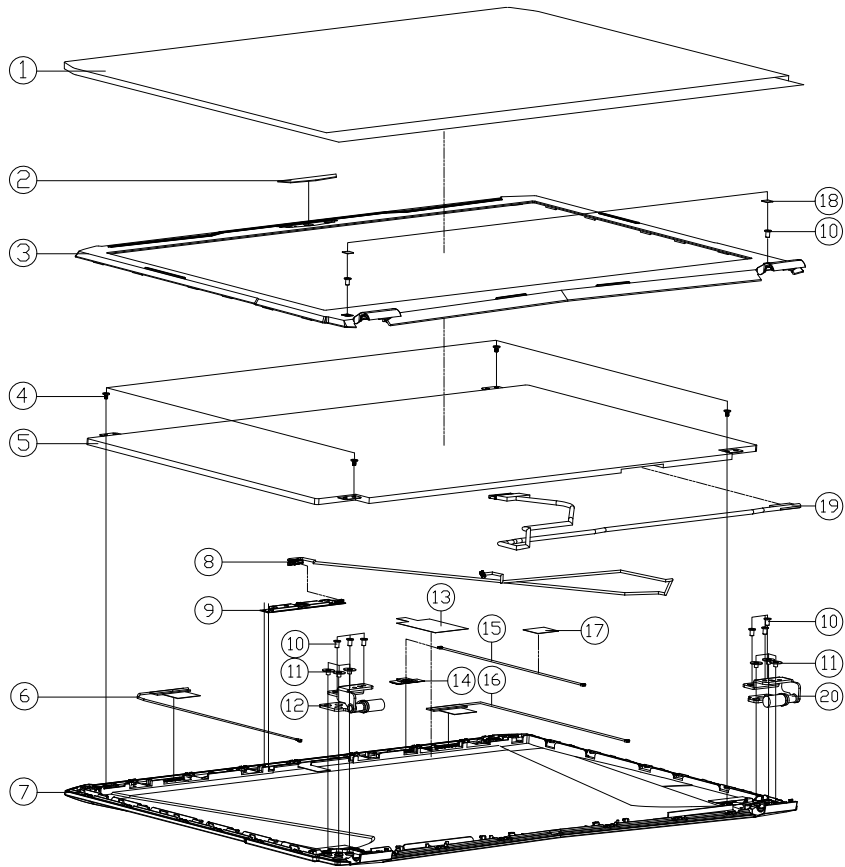

ITEM	PART NAME	PART NO	REMARK
1	BCPP MYLAR 272*437*T=0.05 FDR P670RS	6-40-P67S1-010	
2	CCD LENS PC PA70HS	6-42-PA701-011-1	
3	FRONT COVER MODULE PA70HS	6-39-PA701-013	
4	SCREW M2*4L K1 NI ICT NY (DD=04.5,DT=0.4)	6-35-B3120-3R0	
5	LCD 17.3" 190 / IPS 0H/AD / EIP AU B1732M10 2P SUPPORT 5V+ G-SINC * LED 40M	6-50-N1240-G00	
5	LCD 17.3" FHD/ AAS / M7/EIP INNELUX N1734EE-E31 (LED) 4.0 MM	6-50-NB240-V00	
5	LCD 17.3" FHD/120HZ/MS/NDN G1/EIP INNELUX N1734EE-G32 (LED) 4.0 MM	6-50-NBB40-V070	
5	LCD 17.3" QHD/120HZ/MS/NDN G-SYNCA7/EIP AU B1730T1010 LED 40MM	6-50-N6240-G00	
5	LCD 17.3" FHD / IPS /5V G-SYNCA7N G1/ EIP LG L973W4-SPE3 (LED)50 LED 40MM	6-50-NBB40-L081	
6	ANTENNA IPEX4 WLAN WGT WL1 PCB AR 2.4G/5G L-800MM PA70HS	6-23-7PA70-010	
7	LCD BACK COVER MODULE PA70HS	6-39-PA701-022	
7	LCD BACK COVER MODULE PA71HS	6-39-PA711-021	
8	WIRE CABLE FOR CCD D-MIC 650MM 3.3V 8P (HL) PA70HS	6-43-PA70T-010	
9	INC CAMERA CABLE TX OF 5P/20003011 ON FIB OPTIC W/SDC FIBER WHITE-LED V20-MIC	6-88-W65DC-5100	
9	INC CAMERA CABLE TX 20006570-20 ON FIB OPTIC P7750 FIBER WHITE-LED V20-MIC	6-88-P775C-4901	
10	SCREW M2.5*4L K1 NI ICT NY	6-35-21125-4R0	
11	SCREW M2.5*2.5L K1 BK/Z ICT NY(08,T=0.6)	6-35-B6125-2R5	
12	HINGE L SK7 PA70HS	6-33-PA701-0L1	
13	802.11AD COPPER FOIL P775DM2	6-47-P7751-211	
14	802.11AD MODULE UCI SPANOR 8 500-4002-R2 FOR SPANOR 82-220 MODULE P870M2	6-88-P8722-8100	
15	802.11AD CABLE 640MM M/JA02JAG400TE MURATA CONNECTOR P870M2	6-23-7P872-010	
16	ANTENNA IPEX4 WLAN WGT WL2 PCB AR 2.4G/5G/L2-550MM NCS01V2	6-23-7N350-040	
17	802.11AD TAPE MYLAR(BLACK)X20*15*0.127*P655SRP6	6-40-P655S-P10	
18	FRONT COVER SCREW MYLAR PC P750ZM	6-40-P7508-030	
19	WIRE CABLE FOR EIP 45MM 15V 30PIN (D) 017LV CONN(TC01060200) NOTING	6-43-N8701-010-2N	
19	WIRE CABLE FOR EIP 4K 45MM 15V 30PIN (D) 017LV CONN(V204-202-16) NOTING	6-43-N87K1-010-1N	
19	WIRE CABLE FOR MDCR EIP 4K 45MM 15V 4PIN (D) CONN(LS CONN)SR02 PA70HS	6-43-PA701-011-1S	
20	HINGE R SK7 PA70HS	6-33-PA701-0R1	

Figure A - 5
LCD



Appendix B: Schematic Diagrams

This appendix has circuit diagrams of the *PA70HP6(-G) / PA71HP6* notebook's PCB's. The following table indicates where to find the appropriate schematic diagram.

Diagram - Page	Diagram - Page	Diagram - Page	Diagram - Page
System Block Diagram - Page B - 2	Frame Buffer Partition C_D - Page B - 23	AR Power - Page B - 44	FBVDDQ - Page B - 65
Processor 1/6 - Page B - 3	GPU Decoupling - Page B - 24	TPS65982ABZQZ - Page B - 45	LED Board - Page B - 66
Processor 2/6 - Page B - 4	Straps and XTAL - Page B - 25	USB 3.0 Type C - Page B - 46	LID Board - Page B - 67
Processor 3/6 - Page B - 5	IFP I/O Interface - Page B - 26	PS8338B - Page B - 47	DC Board - Page B - 68
Processor 4/6 - Page B - 6	Misc - GPIO, I2C and ROM - Page B - 27	TPM, CCD, TP - Page B - 48	Power Board - Page B - 69
Processor 5/6 - Page B - 7	NVIDIA Power Sequence - Page B - 28	Connectors - Page B - 49	Click Board - Page B - 70
Processor 6/6 - Page B - 8	GPU NVVDD, FBVDDQ - Page B - 29	Fan, LID, SATA HDD - Page B - 50	Audio Board - Page B - 71
DDR4 CHA SO-DIMM_0 - Page B - 9	GPU GND - Page B - 30	5V, 5VS, 3.3V, 3.3VS, 3.3VA - Page B - 51	USB Board - Page B - 72
DDR4 CHB SO-DIMM_0 - Page B - 10	PCH 1/5 - Page B - 31	I.0DX_VCCSTG/VCCSFR_OC/2.5V - Page B - 52	USB 3.0 Board - Page B - 73
Panel, Inverter - Page B - 11	PCH 2/5 - Page B - 32	IV8_RUN/AON, NV3V3 - Page B - 53	PA7 Card Reader Board 1/4 - Page B - 74
Mini DP Port (Back) - Page B - 12	PCH 3/5 - Page B - 33	PEX_VDD - Page B - 54	PA7 Card Reader Board 2/4 - Page B - 75
Mini DP Port (Front) - Page B - 13	PCH 4/5 - Page B - 34	VDD3, VDD5 - Page B - 55	PA7 Card Reader Board 3/4 - Page B - 76
HDMI Connector - Page B - 14	PCH 5/5 - Page B - 35	DDR 1.2V / 0.6VS - Page B - 56	PA7 Card Reader Board 4/4 - Page B - 77
VGA PCI Express - Page B - 15	KBC IT8587 - Page B - 36	Power 1.0V, VCCIO - Page B - 57	Power Sequence - Page B - 78
GPU Frame Buffer Partition - Page B - 16	RGB and White KB LED - Page B - 37	VCC_Core - Page B - 58	
Frame Buffer Partition A - Page B - 17	M.2 PCIE4X SSD - Page B - 38	VCore & VCCGT Output - Page B - 59	
Frame Buffer Partition B - Page B - 18	M.2 3G/LTE/WIGIG/WLAN+BT - Page B - 39	VCCSA - Page B - 60	
Frame Buffer Partition A_B - Page B - 19	Audio - Page B - 40	AC_In, Charger - Page B - 61	
GPU Frame Buffer Partition - Page B - 20	Audio Subwoofer - Page B - 41	NVVDDS - Page B - 62	
Frame Buffer Partition C - Page B - 21	Audio Port 1 - Page B - 42	NVVDD 1 - Page B - 63	
Frame Buffer Partition D - Page B - 22	AR_TBT - Page B - 43	NVVDD 2 - Page B - 64	

Table B - 1
**SCHEMATIC
DIAGRAMS**



Version Note

The schematic diagrams in this chapter are based upon version 6-7P-PA70C-001. If your mainboard (or other boards) are a later version, please check with the Service Center for updated diagrams (if required).

System Block Diagram

Sheet 1 of 77
System Block
Diagram

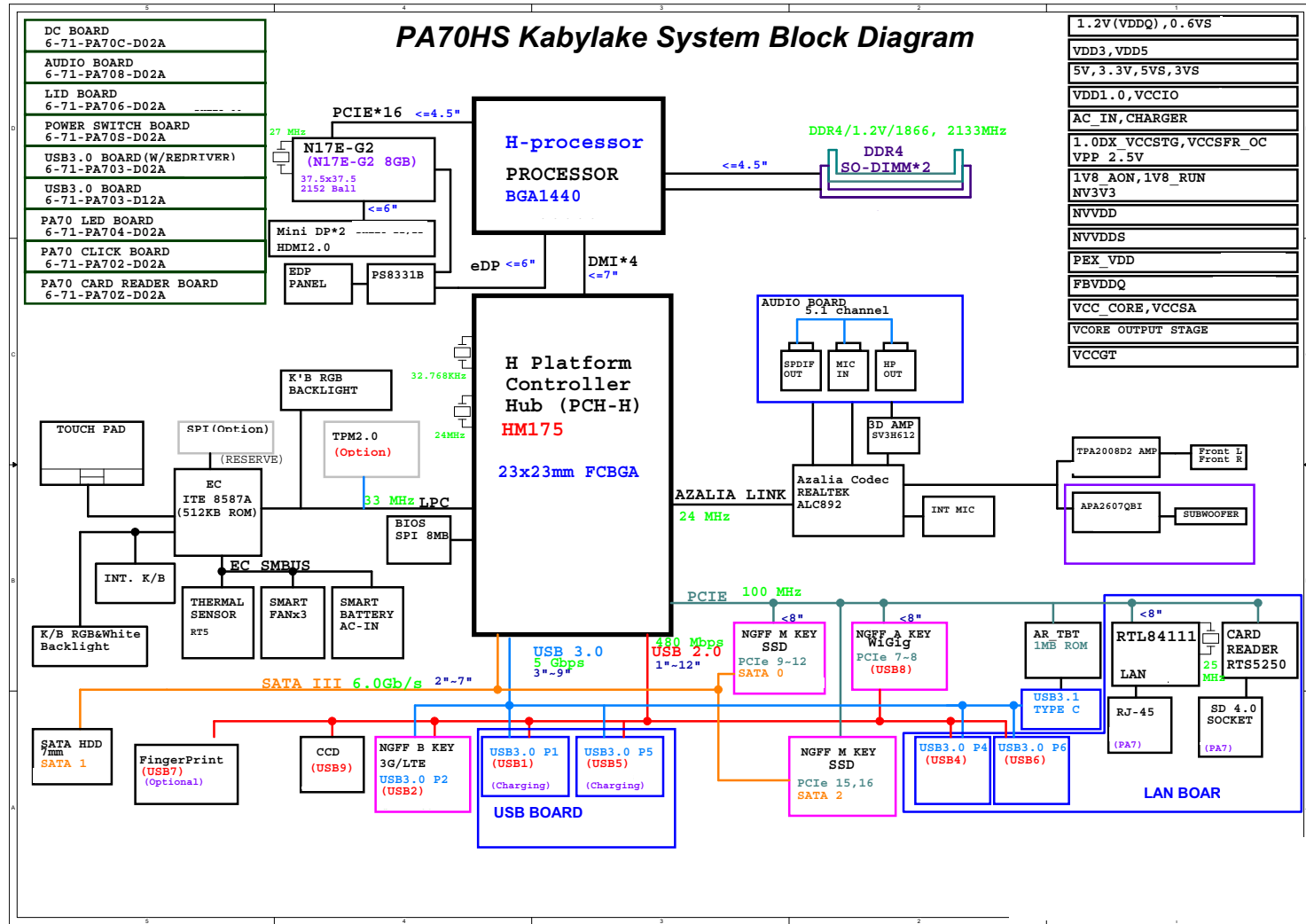

Processor 1/6

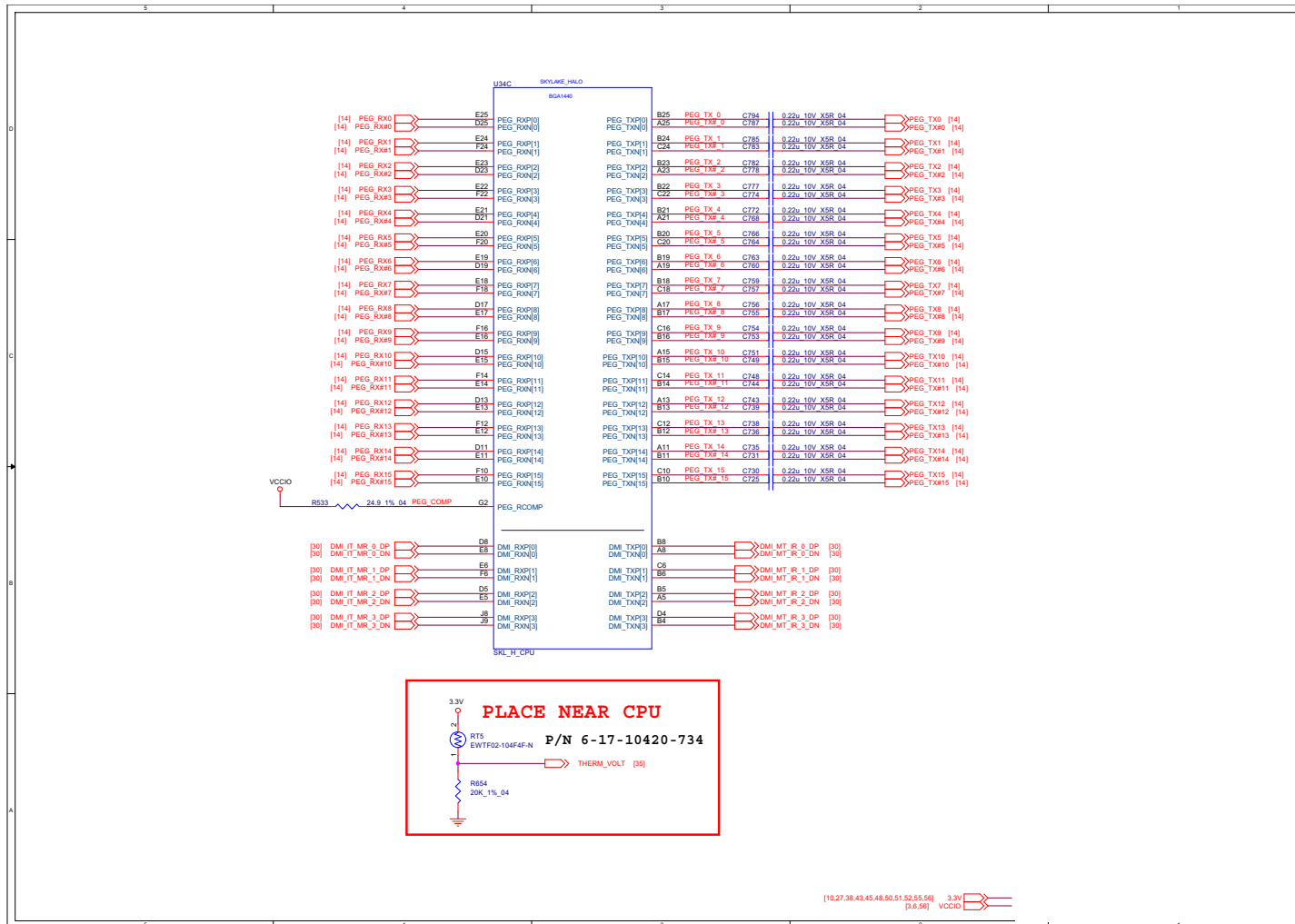

Sheet 2 of 77
Processor 1/6

B.Schematic Diagrams

Processor 2/6

Sheet 3 of 77
Processor 2/6

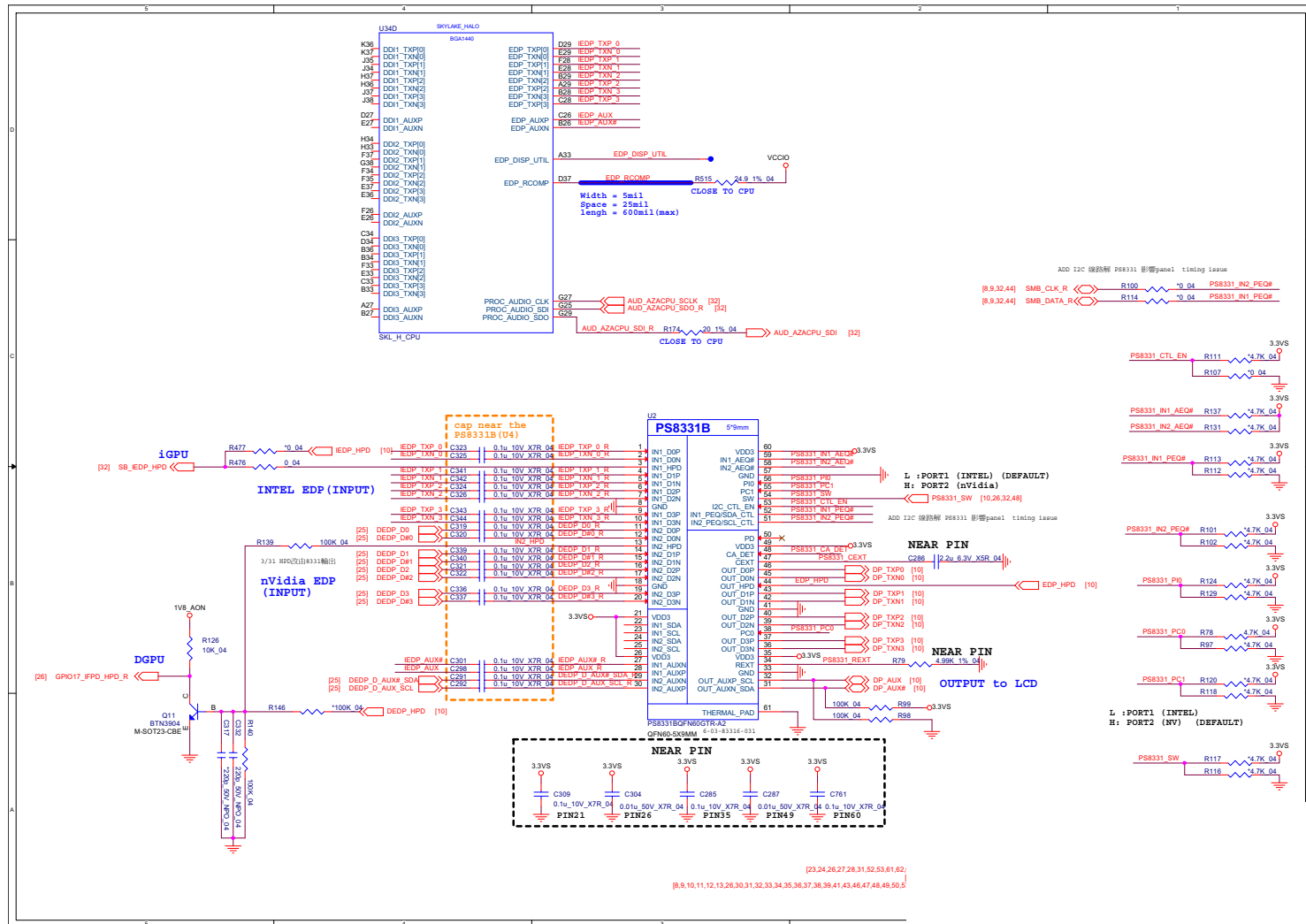

Processor 3/6

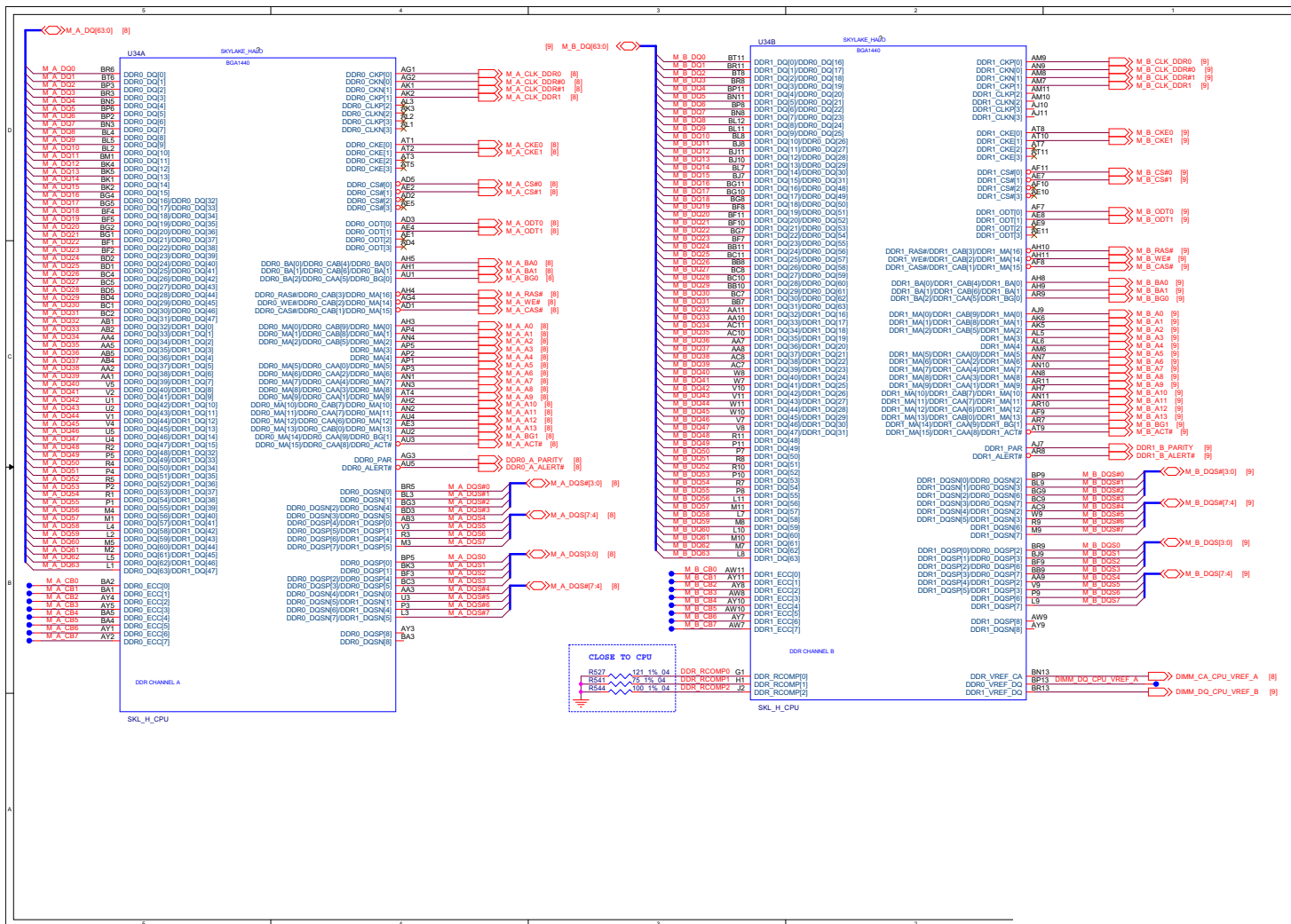

Sheet 4 of 77
Processor 3/6

B.Schematic Diagrams

Processor 4/6

Sheet 5 of 77
Processor 4/6

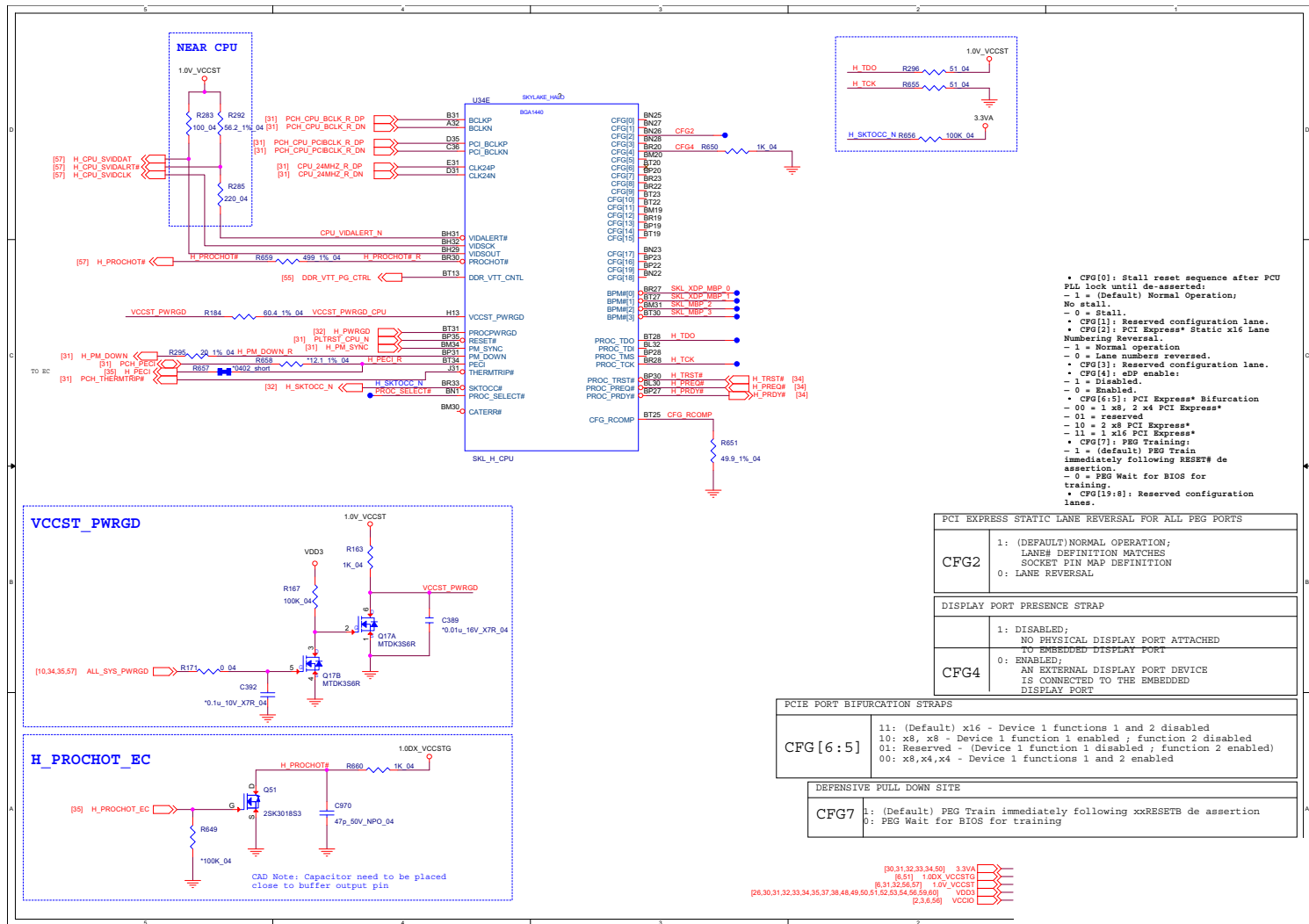

Processor 5/6

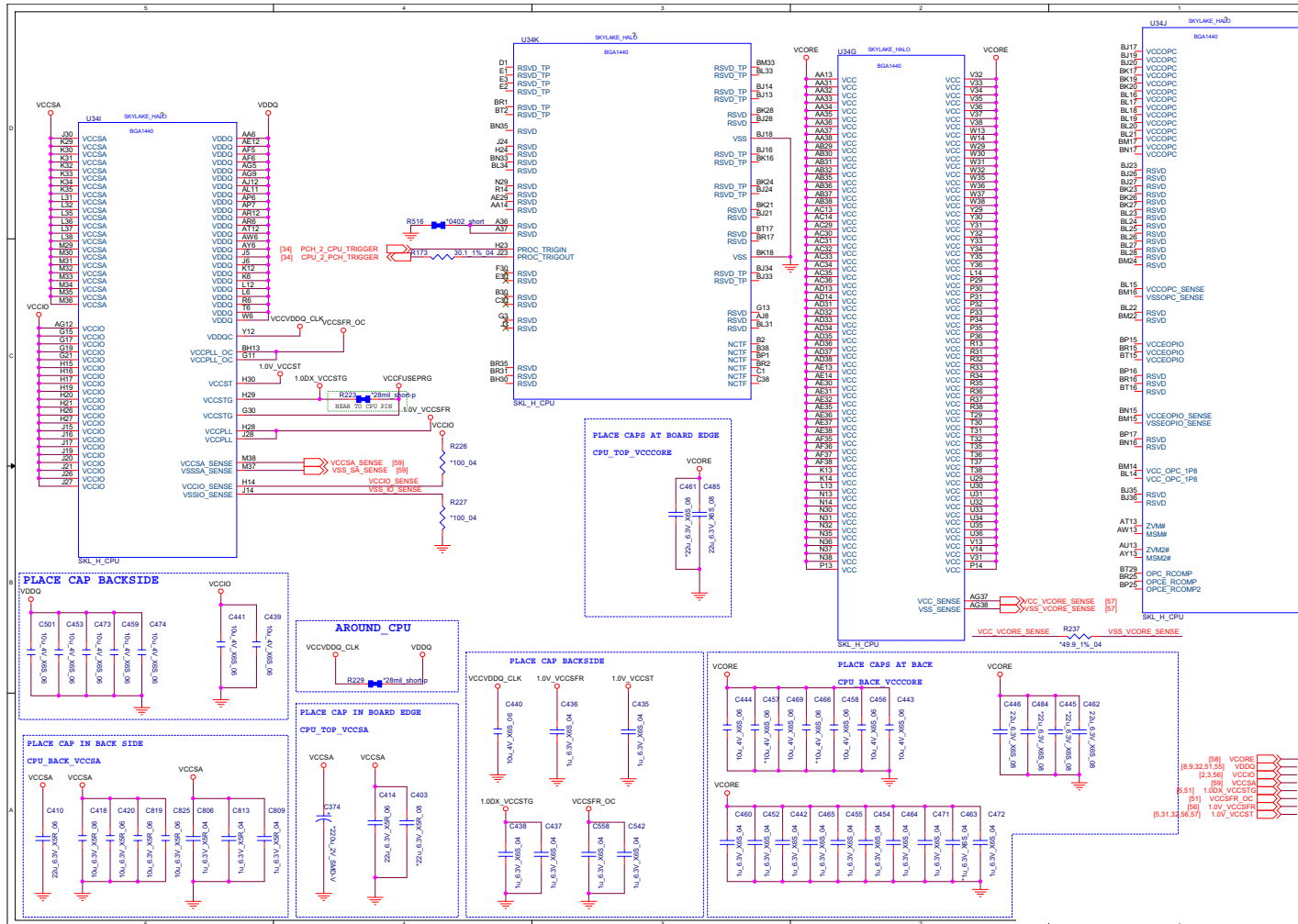

Sheet 6 of 77
Processor 5/6

Processor 6/6

Sheet 7 of 77
Processor 6/6

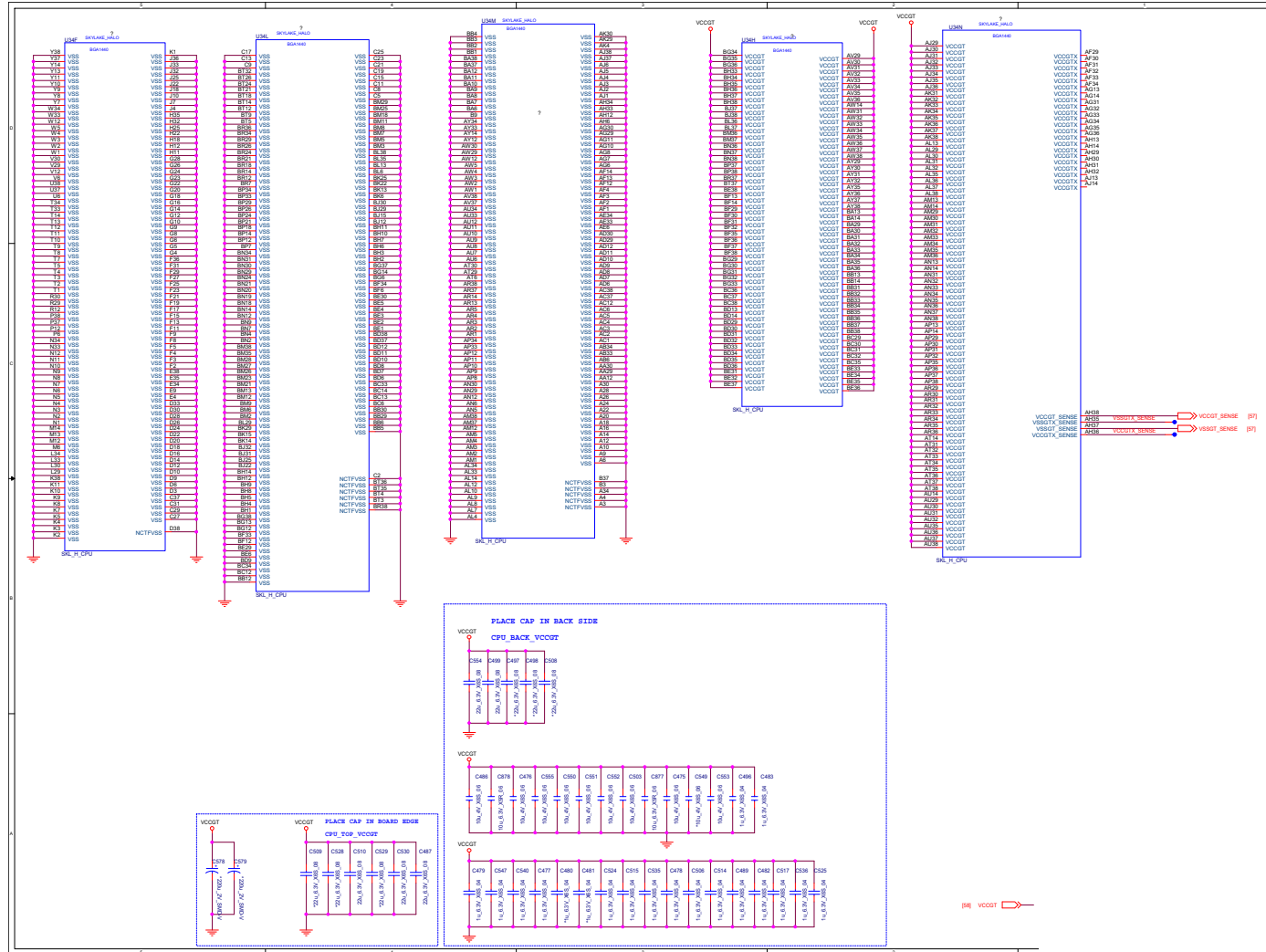

DDR4 CHA SO-DIMM_0

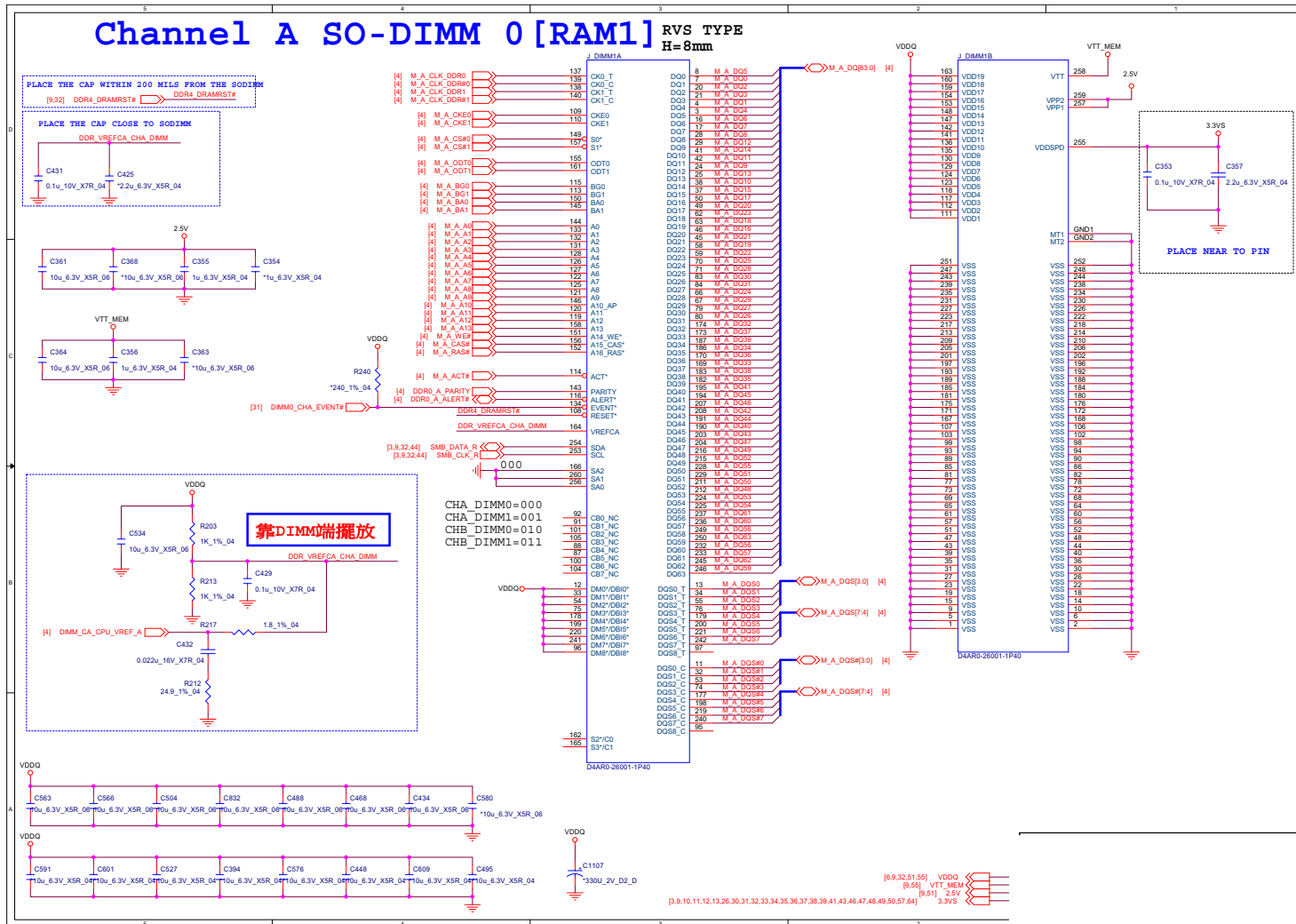

Sheet 8 of 77
DDR4 CHA SO-DIMM_0

B.Schematic Diagrams

Schematic Diagrams

DDR4 CHB SO-DIMM_0

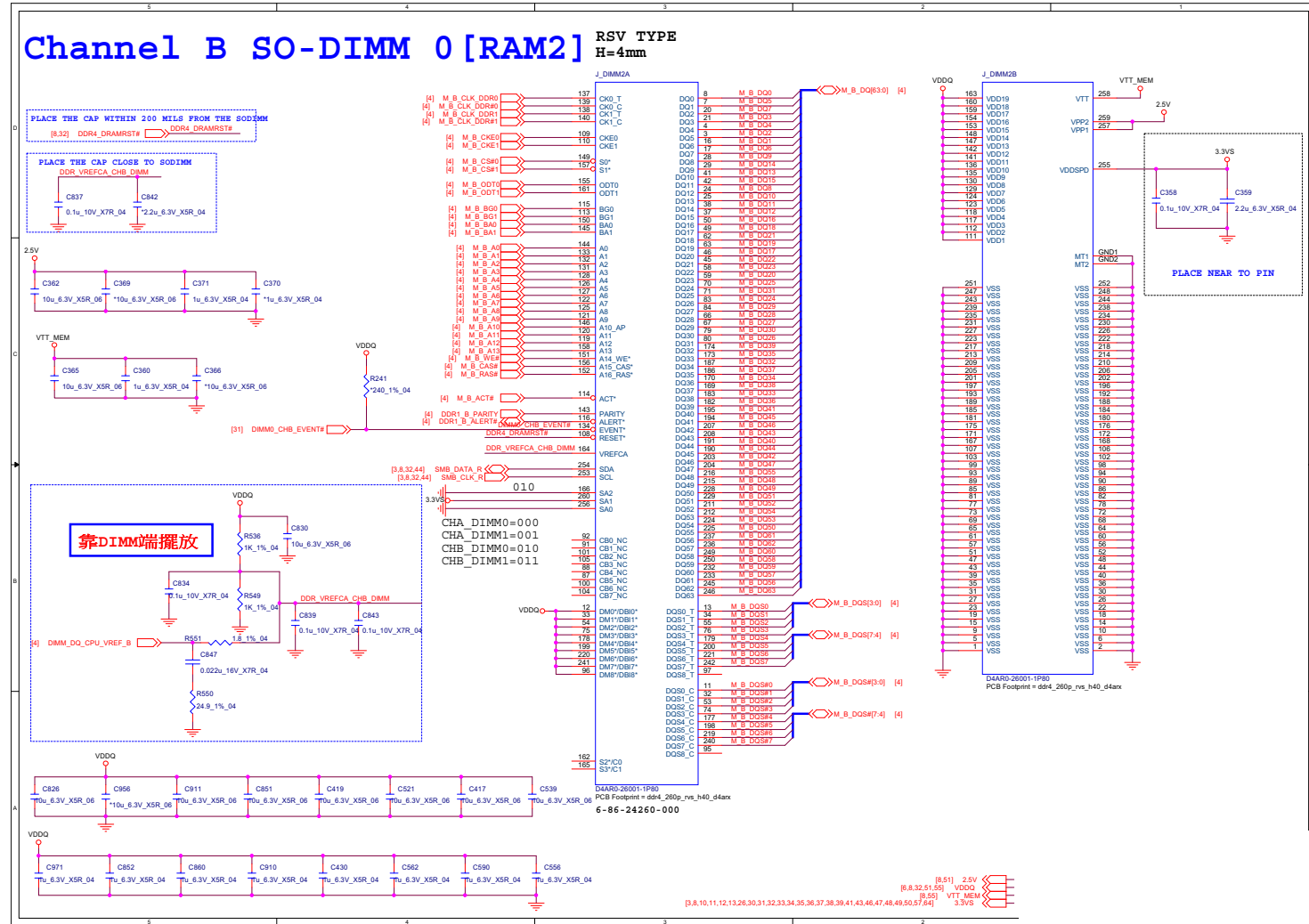

Panel, Inverter

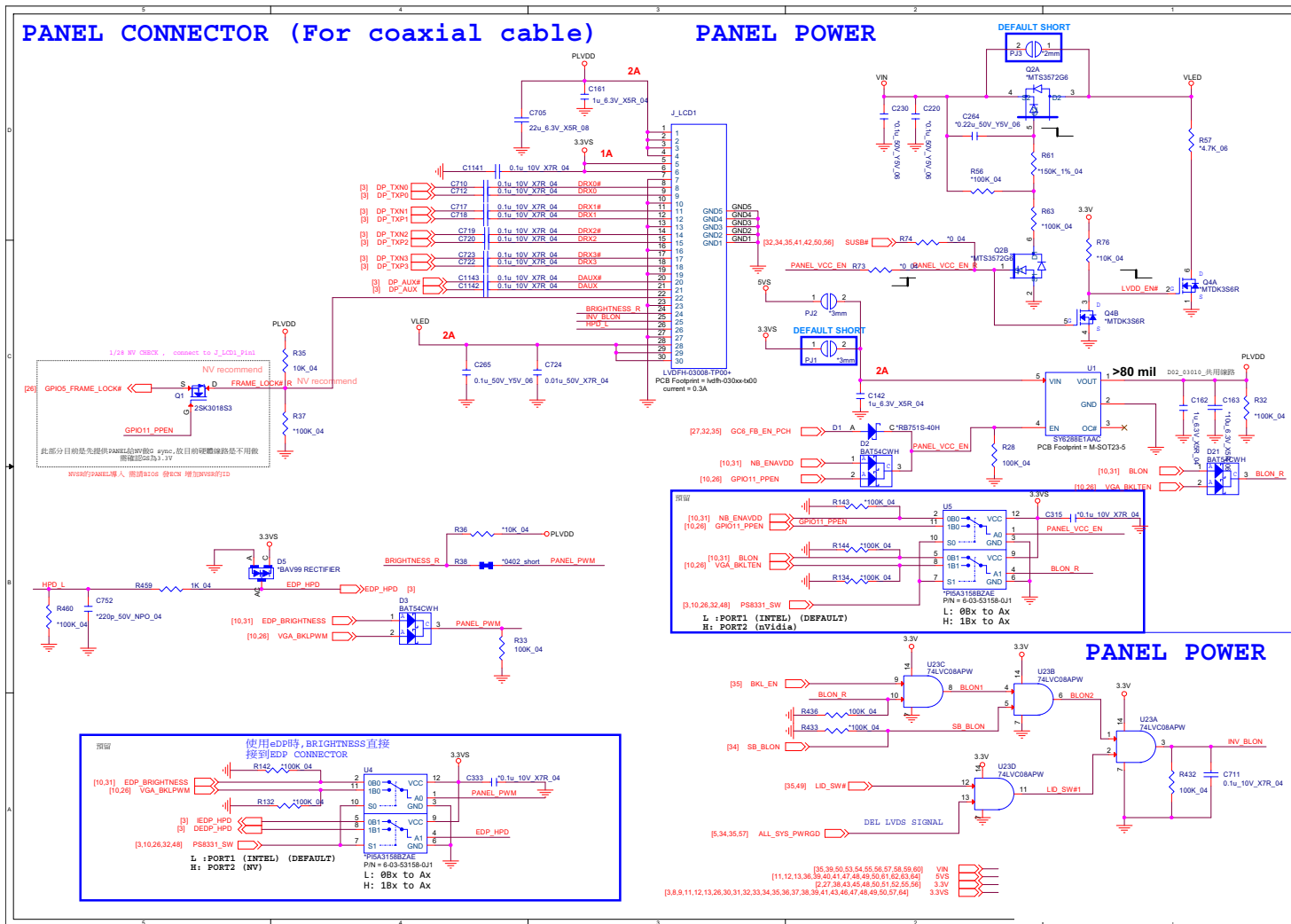

Sheet 10 of 77
Panel, Inverter

B.Schematic Diagrams

Mini DP Port (Back)

B.Schematic Diagrams

Sheet 11 of 77
Mini DP Port (Back)

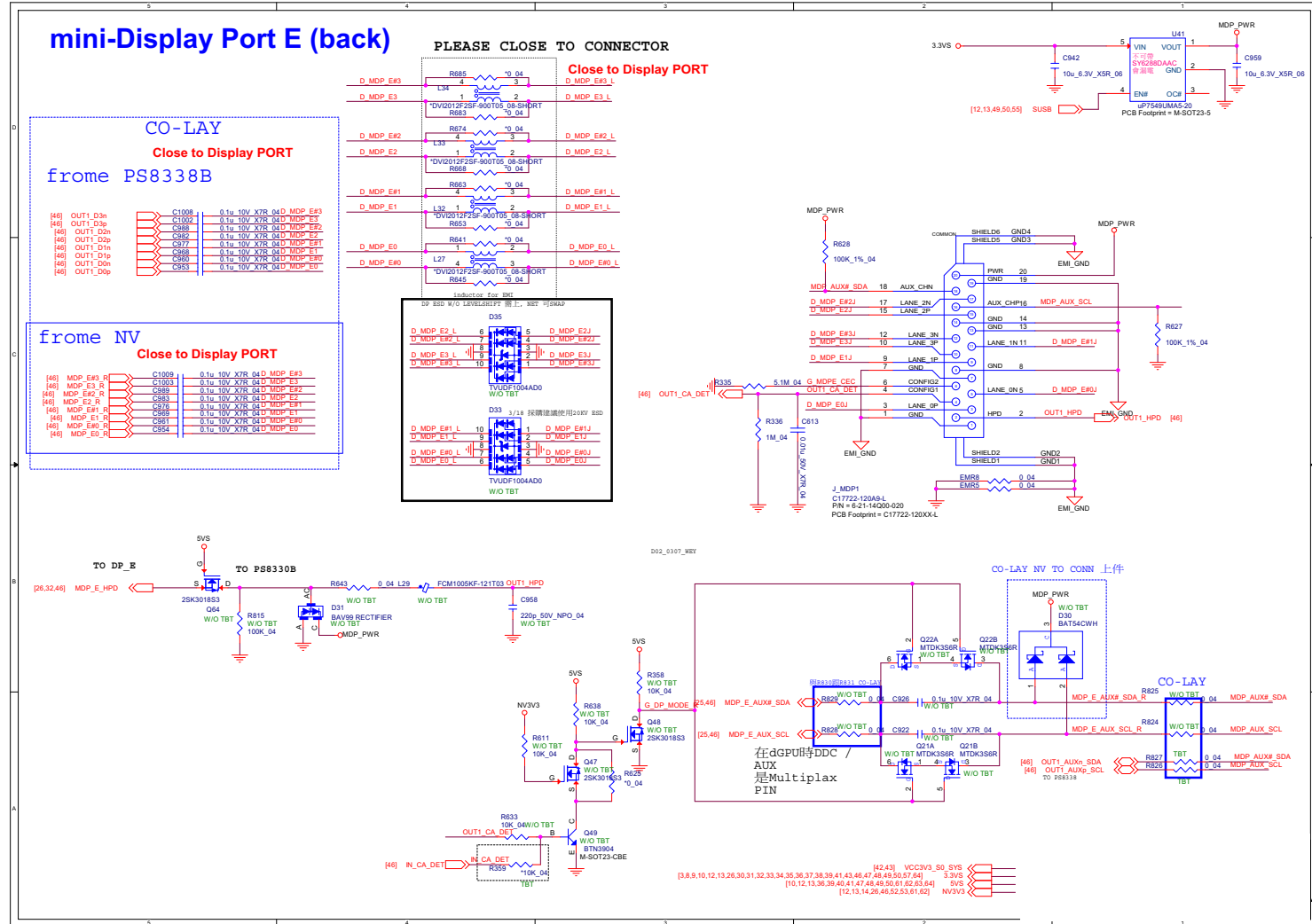

Mini DP Port (Front)

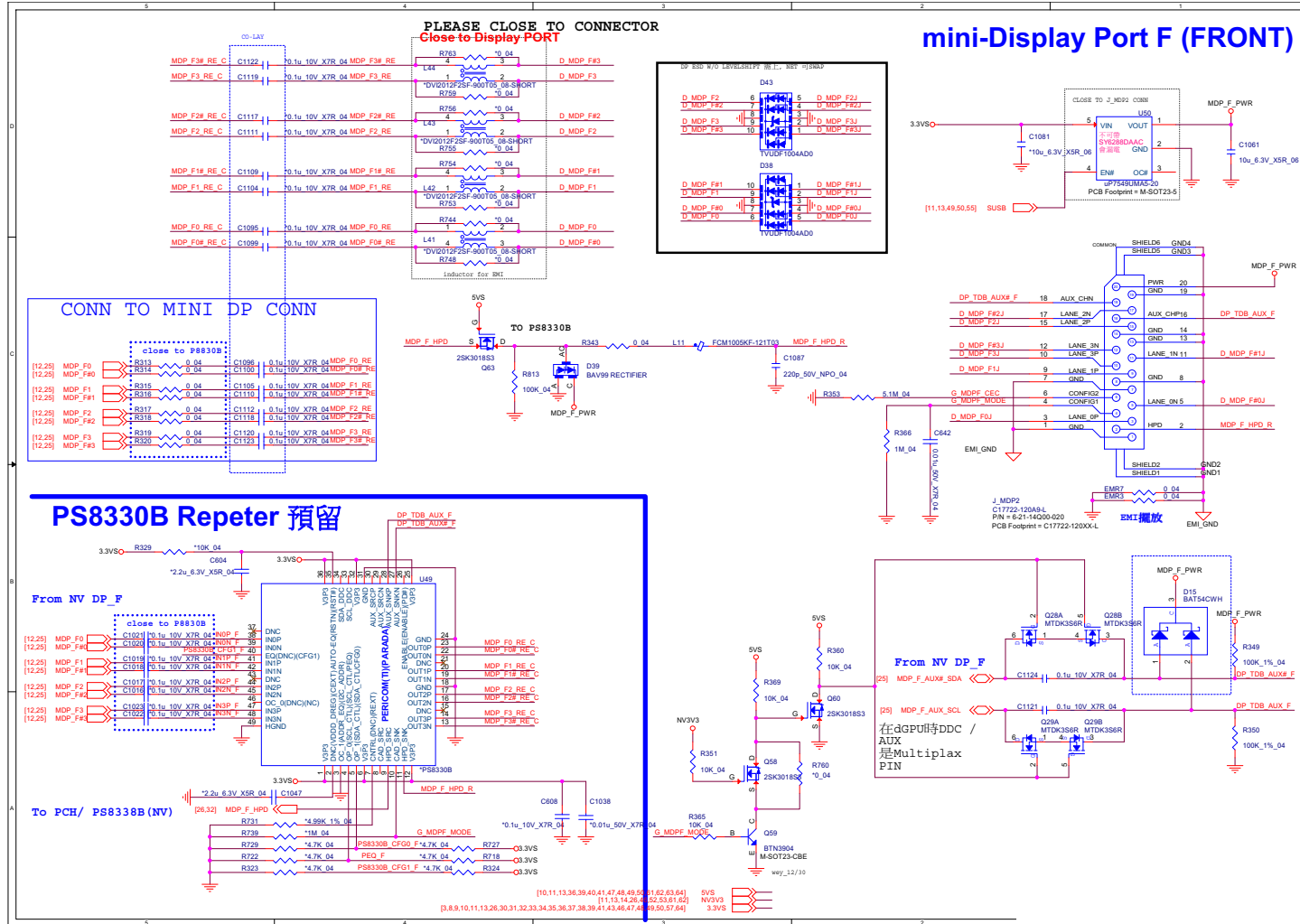

Sheet 12 of 77
Mini DP Port (Front)

B.Schematic Diagrams

HDMI Connector

Sheet 13 of 77
HDMI Connector

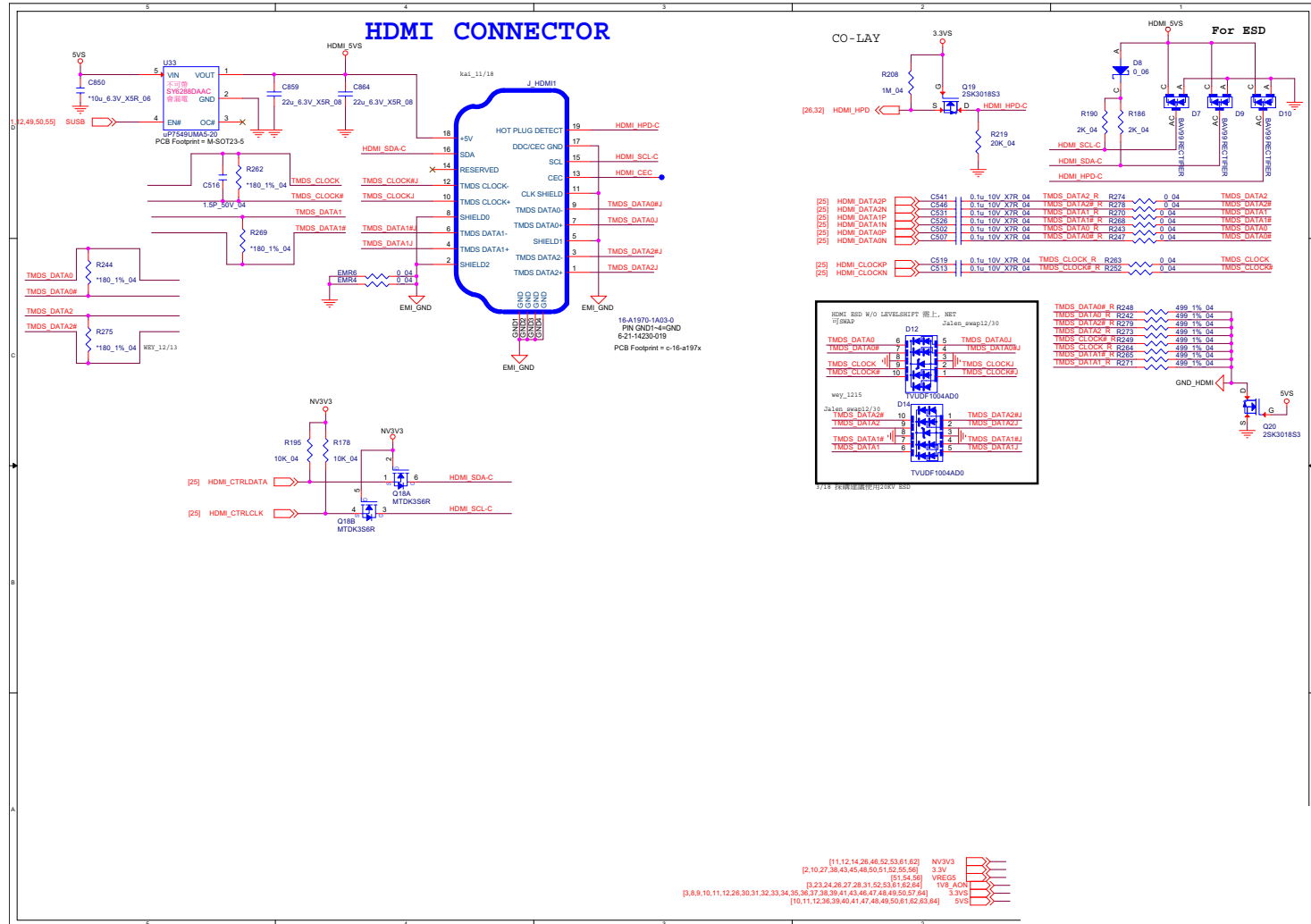

GPU Frame Buffer Partition

Sheet 15 of 77
GPU Frame Buffer Partition

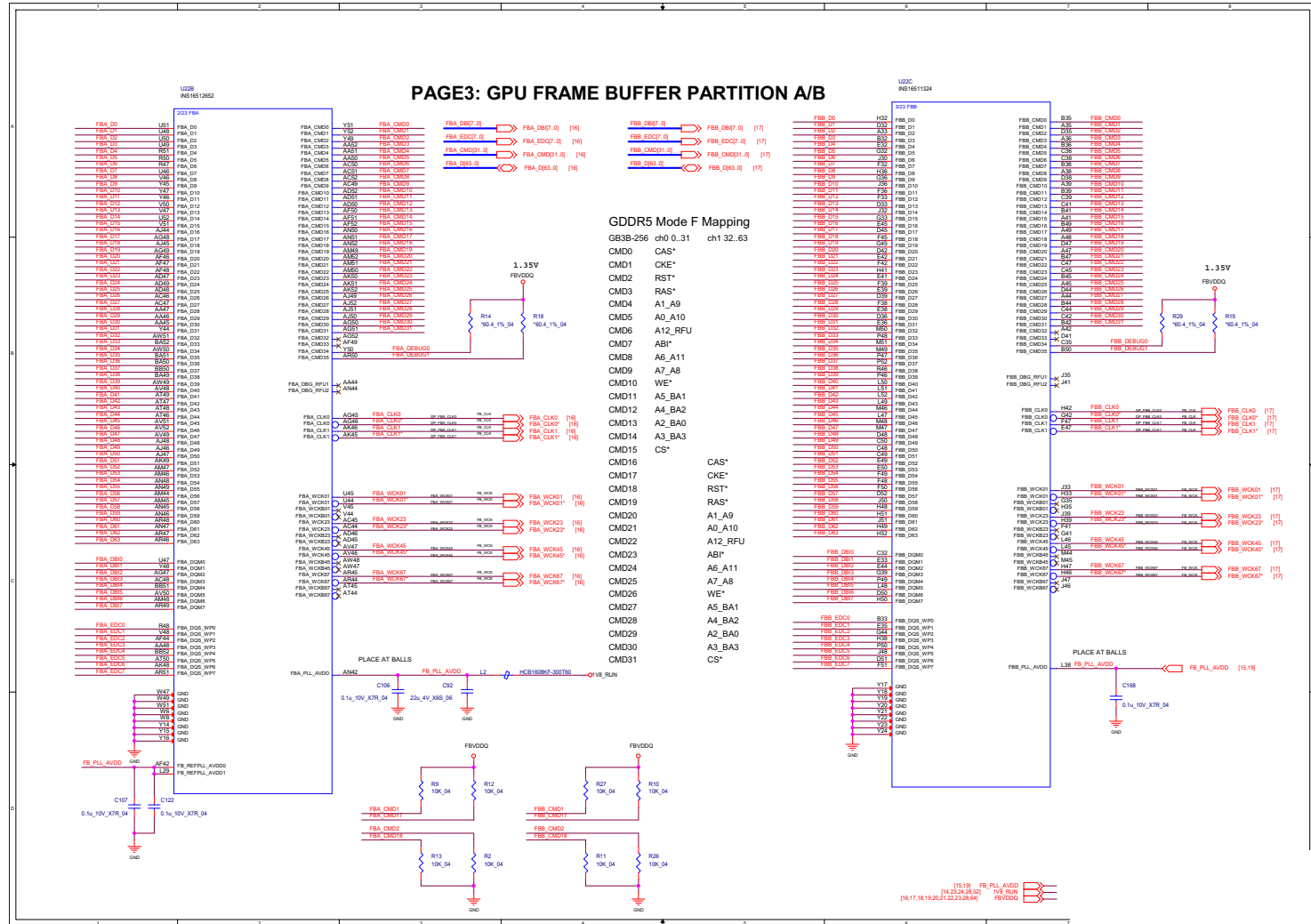

Frame Buffer Partition A

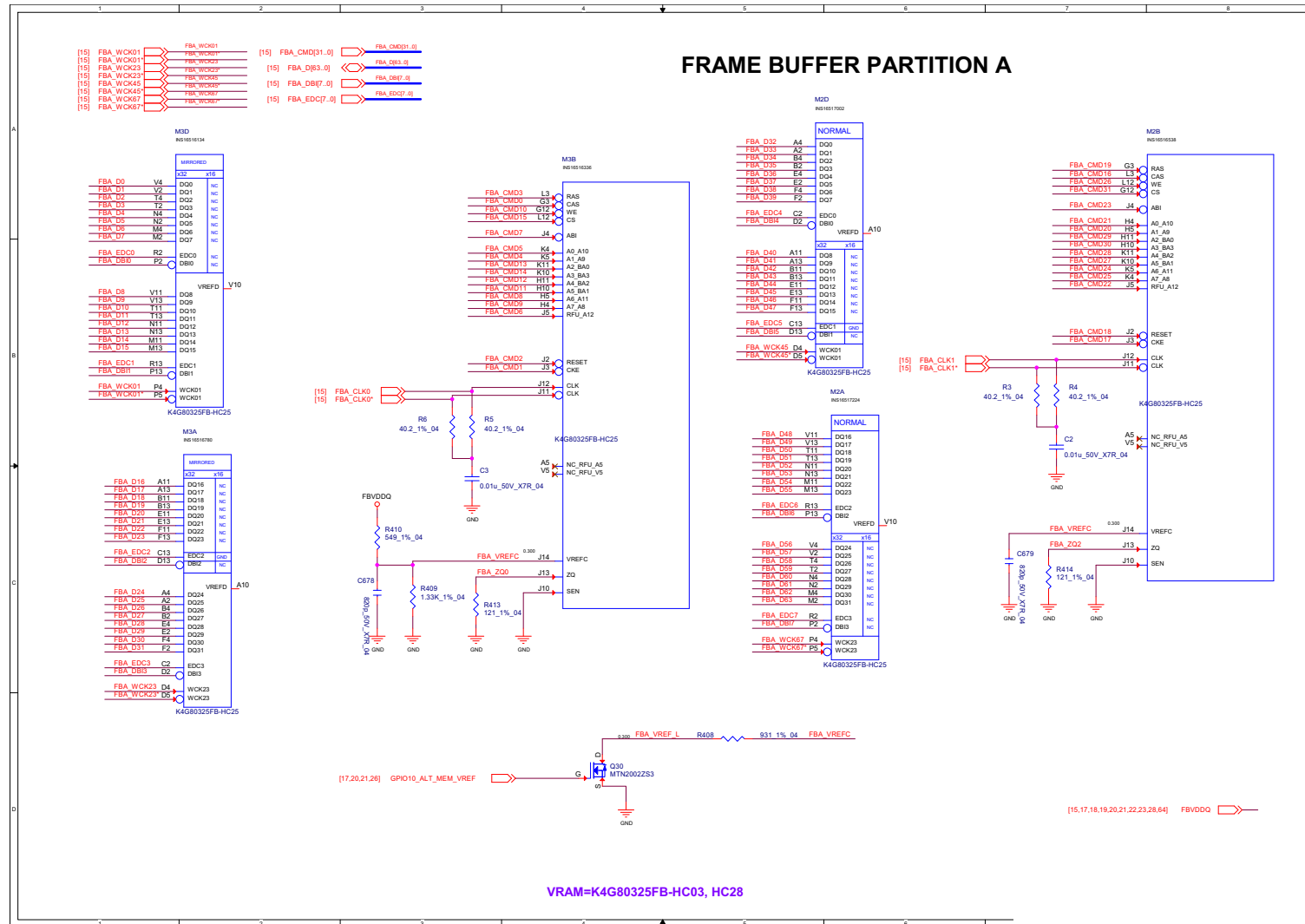

Sheet 16 of 77
Frame Buffer
Partition A

B.Schematic Diagrams

Frame Buffer Partition B

Sheet 17 of 77
Frame Buffer
Partition B

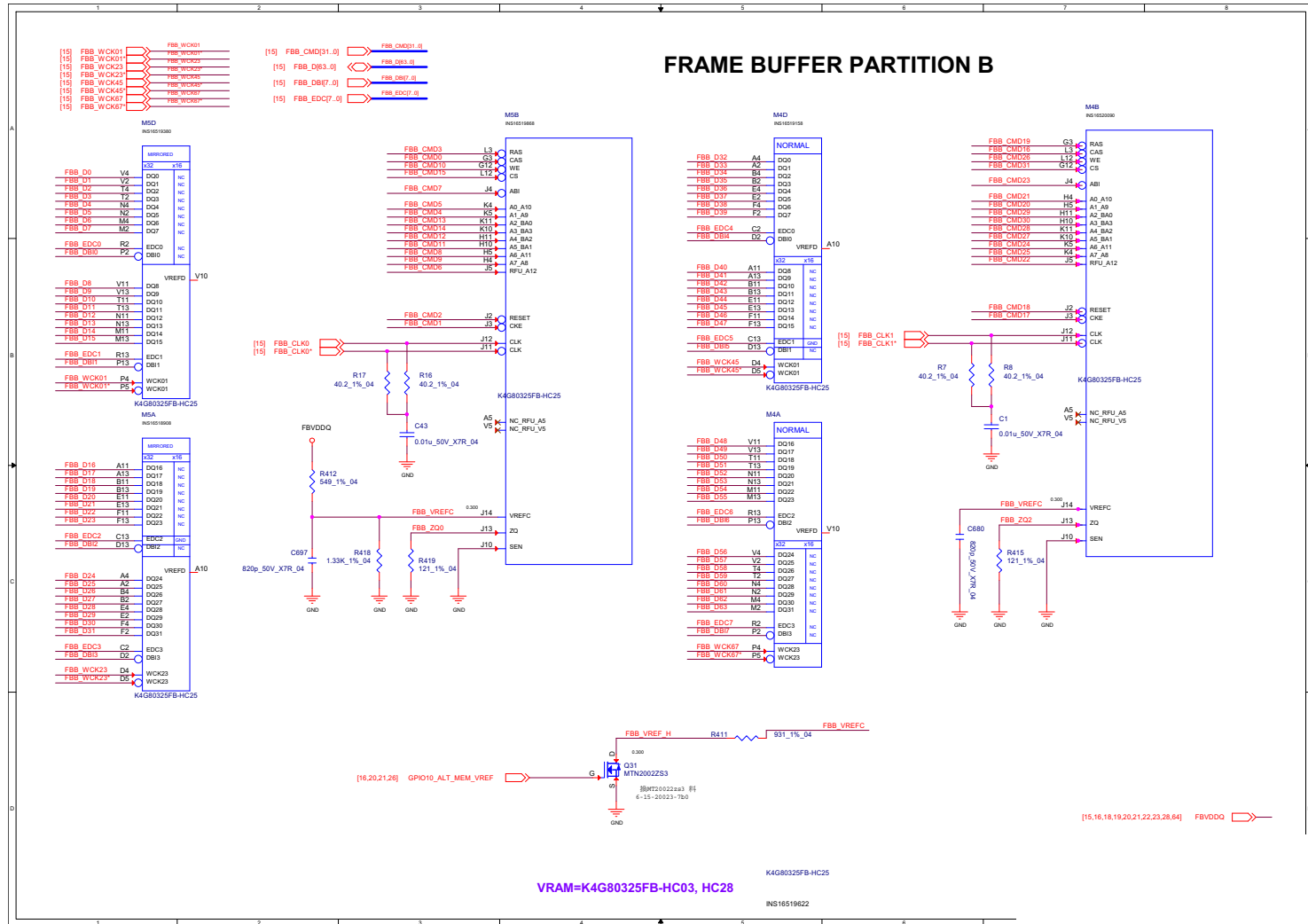

Frame Buffer Partition A_B

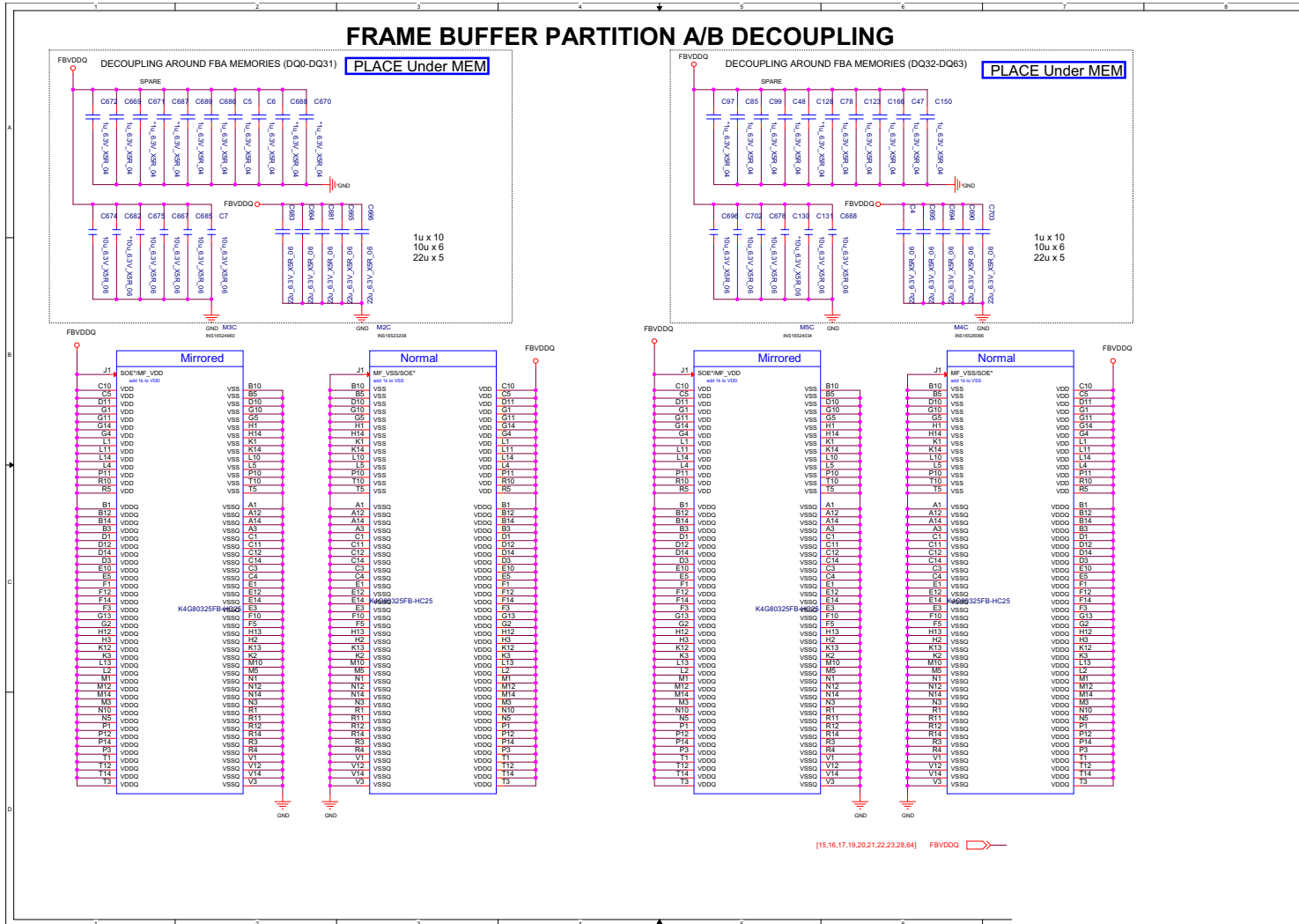

Sheet 18 of 77
Frame Buffer
Partition A_B

B.Schematic Diagrams

GPU Frame Buffer Partition

B.Schematic Diagrams

Sheet 19 of 77
GPU Frame Buffer Partition

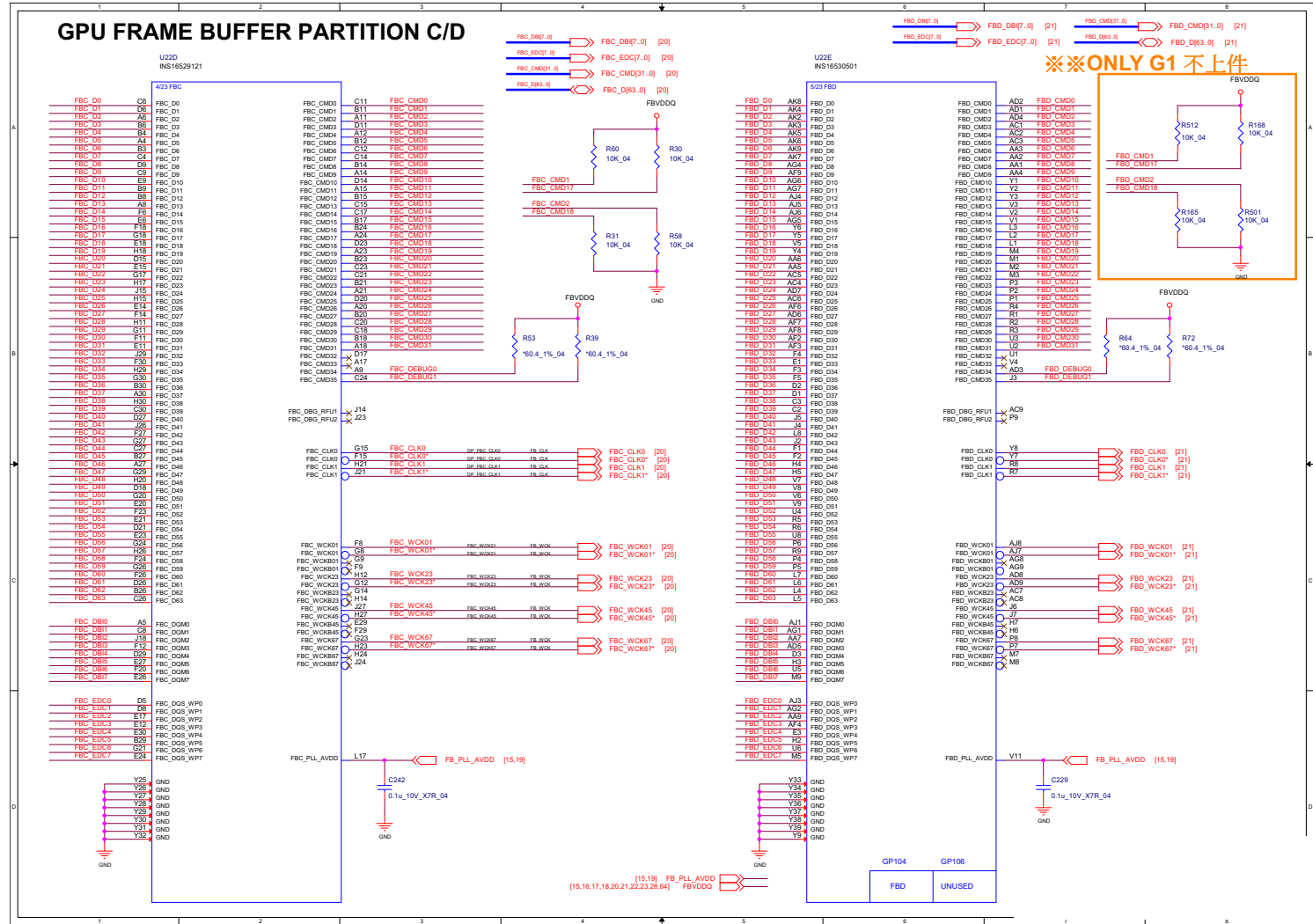

Frame Buffer Partition C

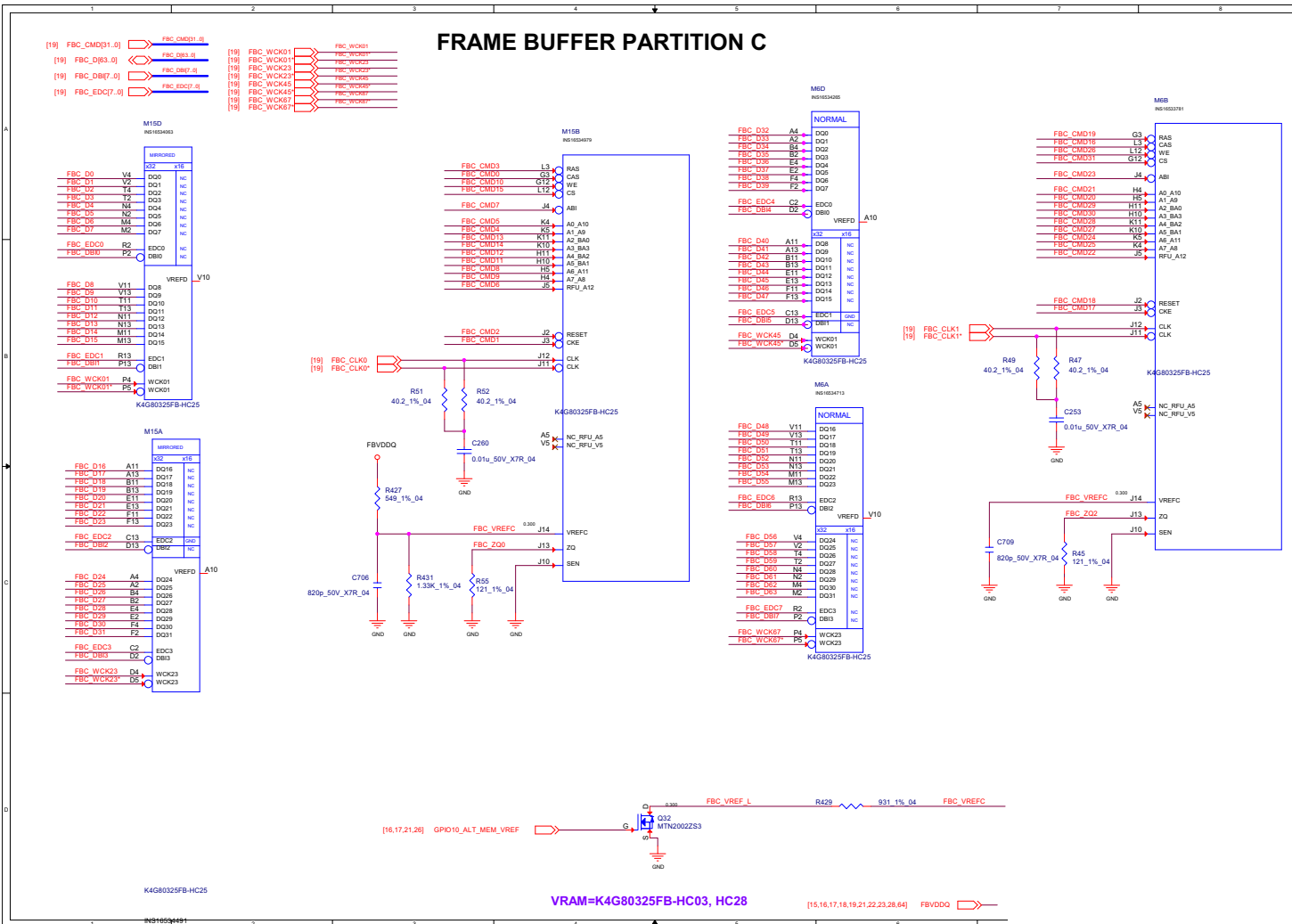

B.Schematic Diagrams

Frame Buffer Partition D

Sheet 21 of 77
Frame Buffer
Partition D

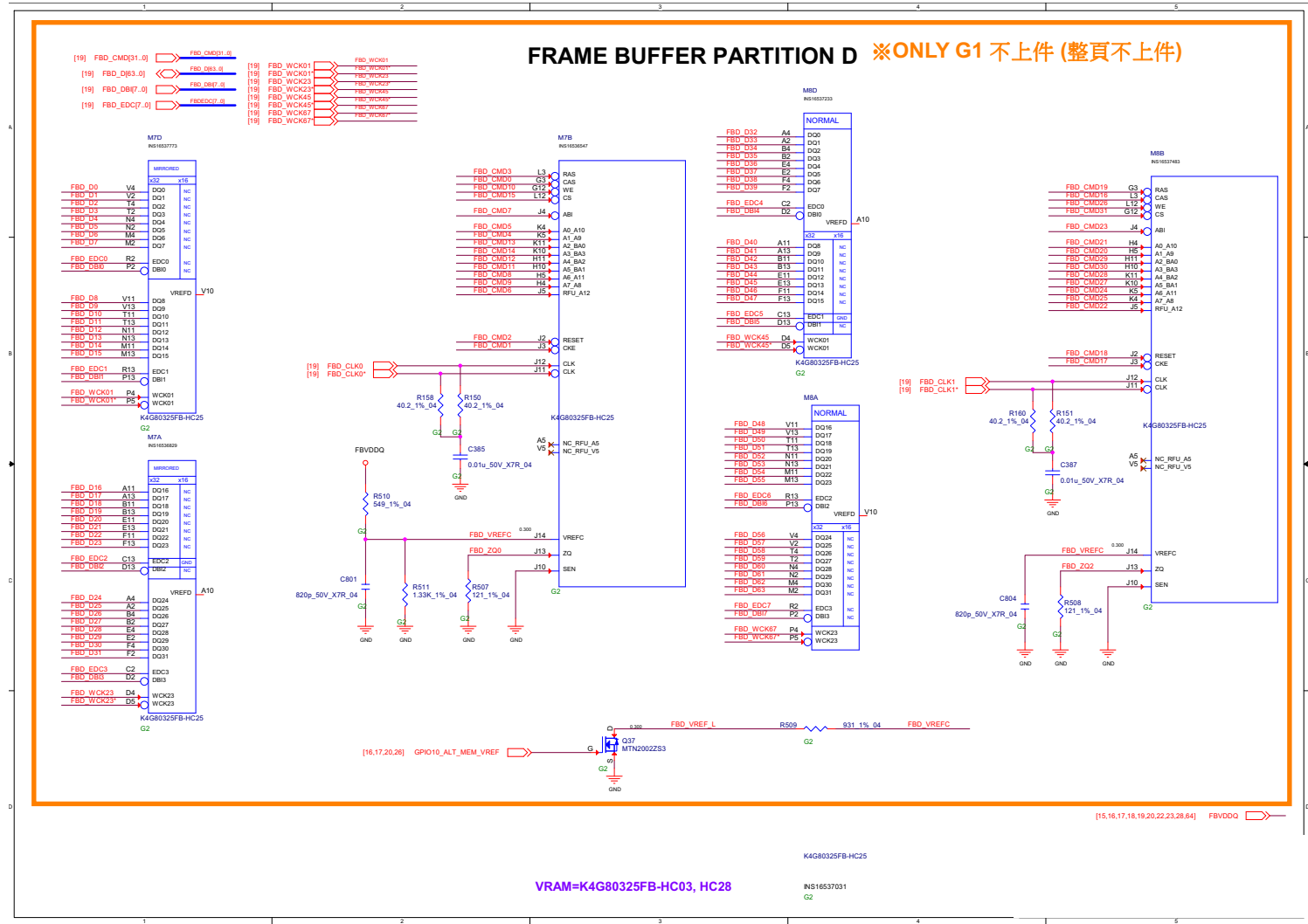

Frame Buffer Partition C_D

B.Schematic Diagrams

Sheet 22 of 77
Frame Buffer
Partition C_D

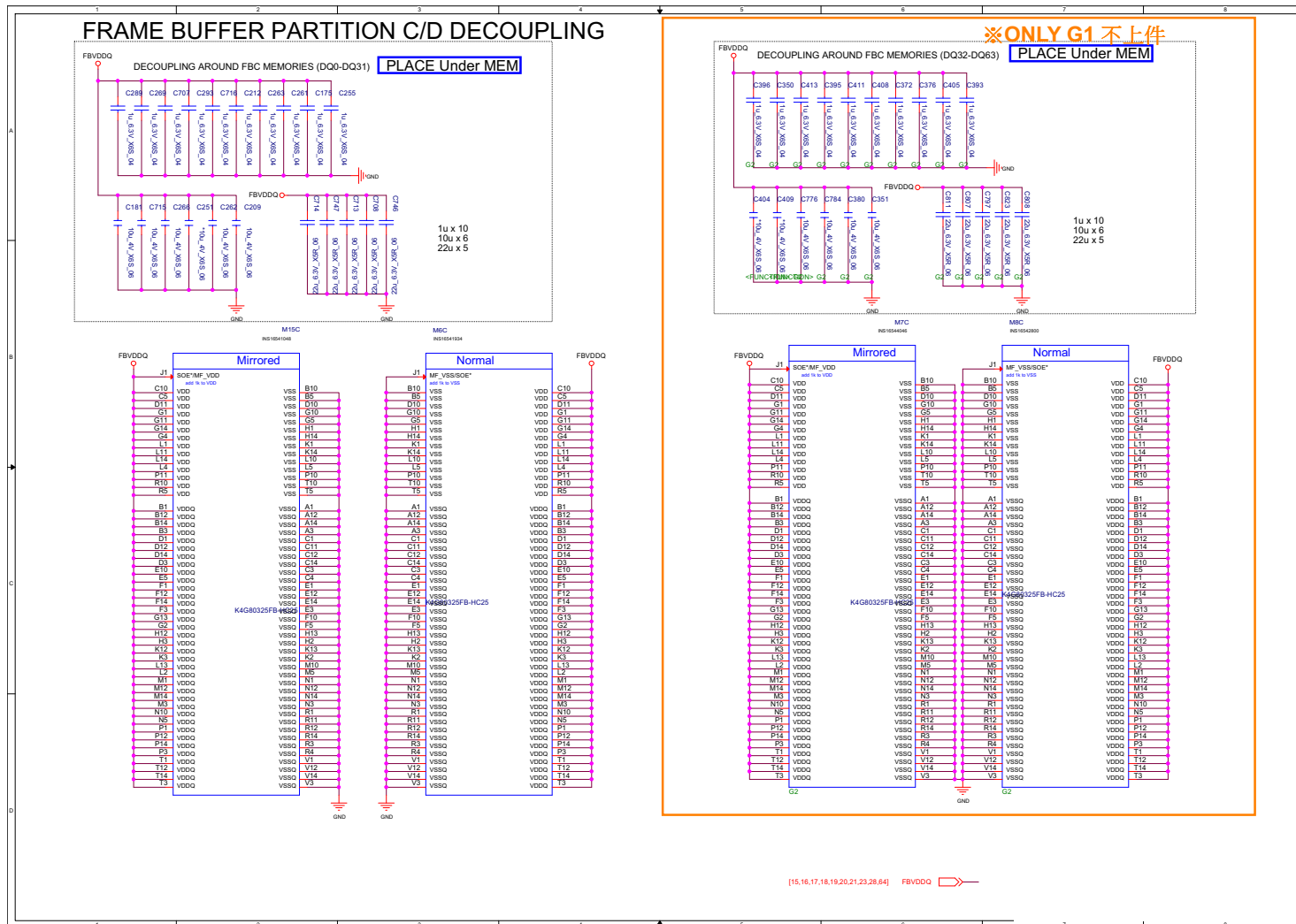

GPU Decoupling

Sheet 23 of 77
GPU Decoupling



Schematic Diagrams

IFP I/O Interface

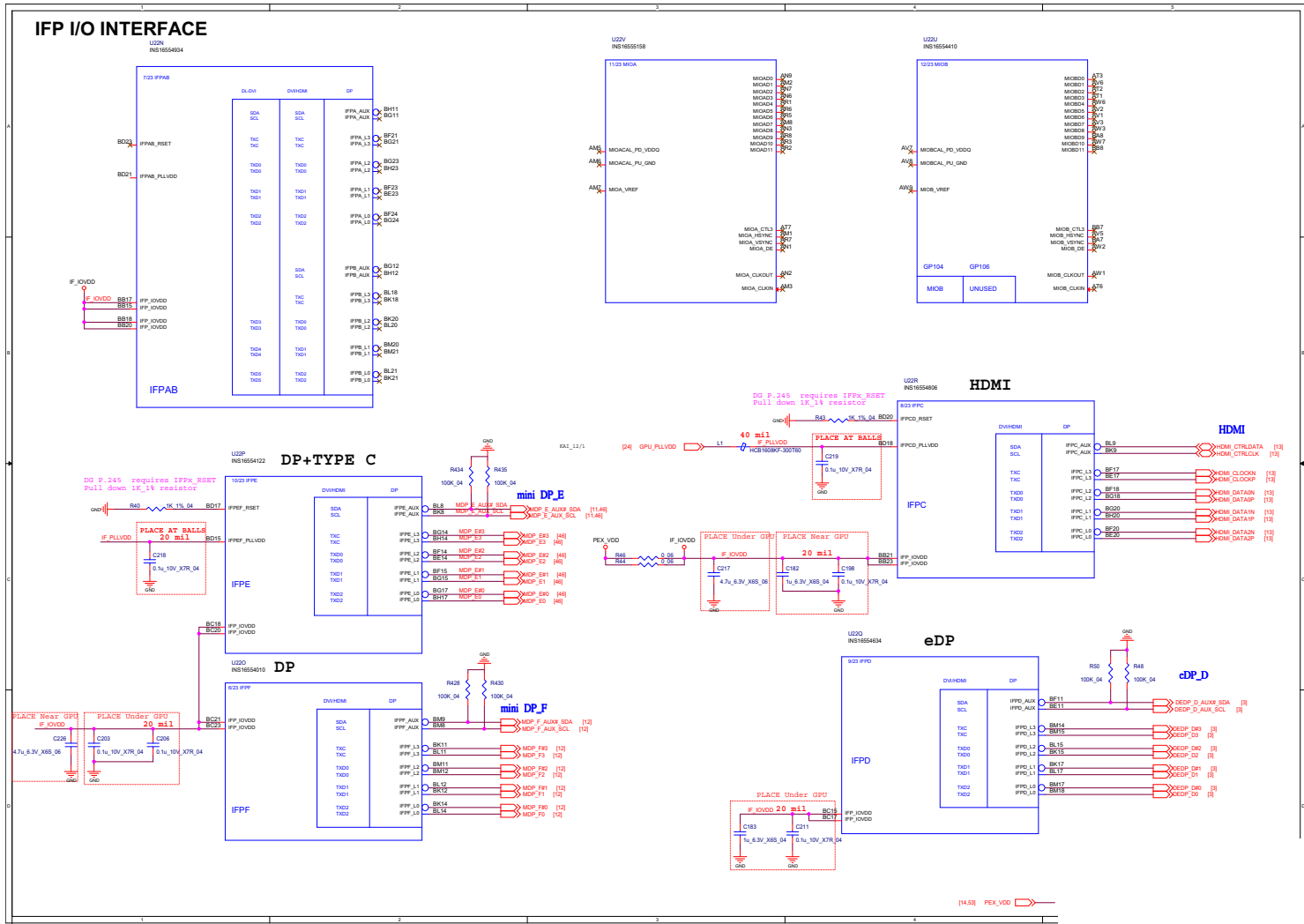

B.Schematic Diagrams

Sheet 25 of 77
IFP I/O Interface

NVIDIA Power Sequence

Sheet 27 of 77
NVIDIA Power
Sequence

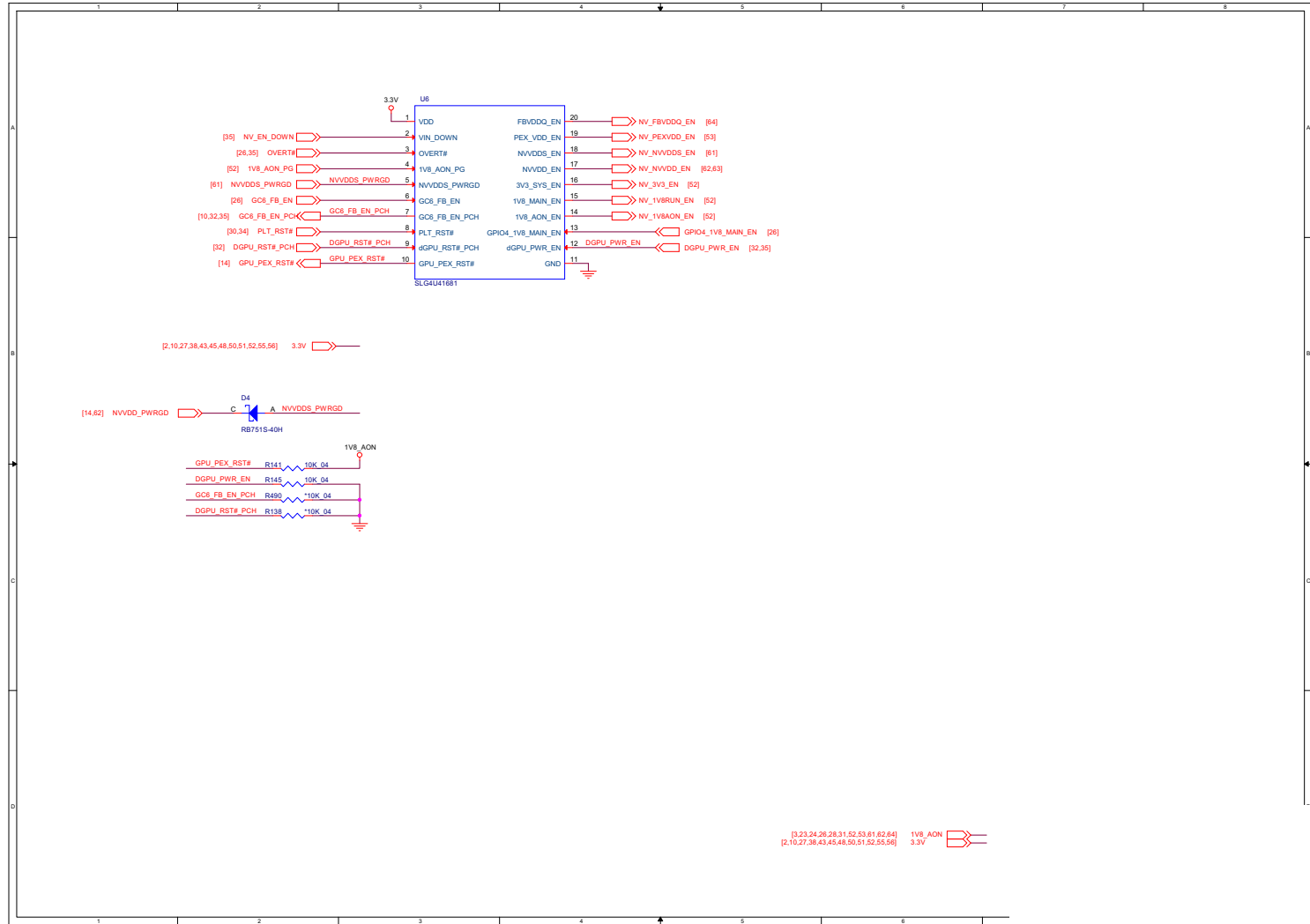

GPU NVVDD, FBVDDQ

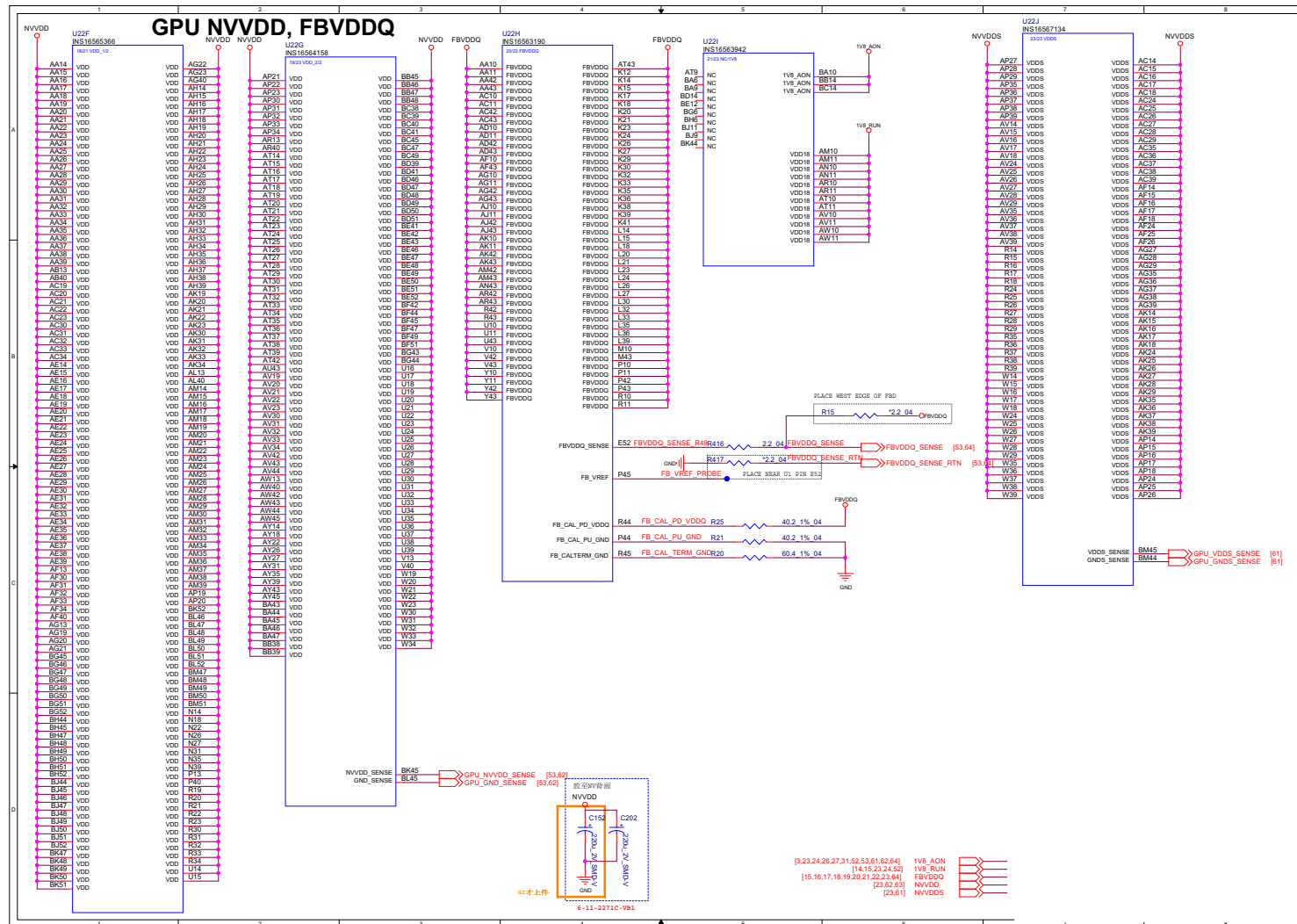

Sheet 28 of 77
GPU NVVDD,
FBVDDQ

B.Schematic Diagrams

PCH 5/5

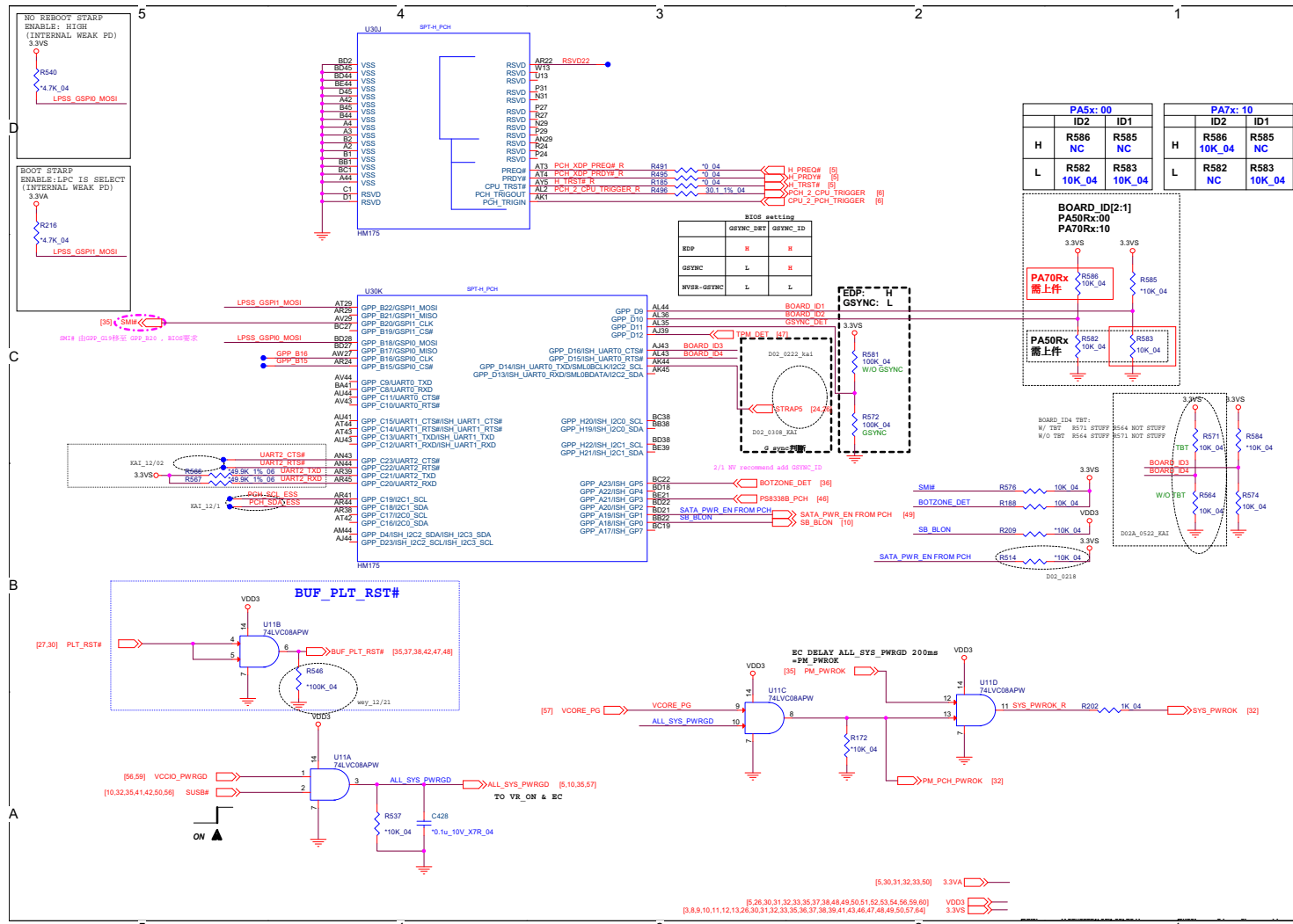

Sheet 34 of 77
PCH 5/5

KBC IT8587

Sheet 35 of 77
KBC IT8587

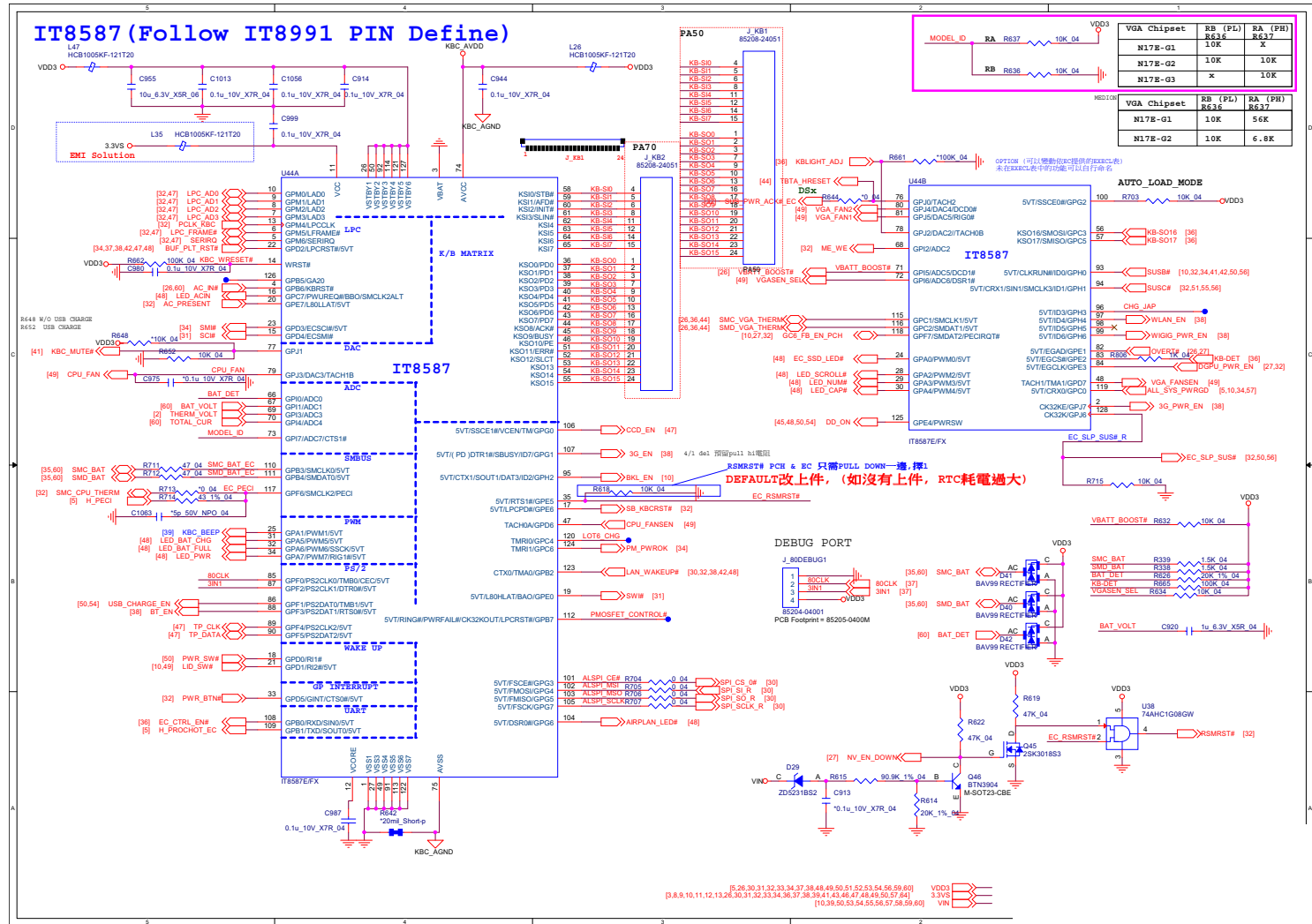

RGB and White KB LED

KEYBOARD RGB LED

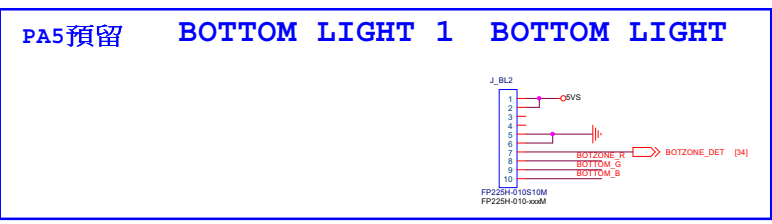
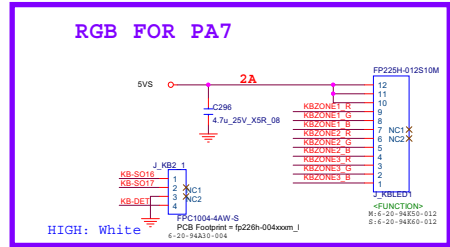
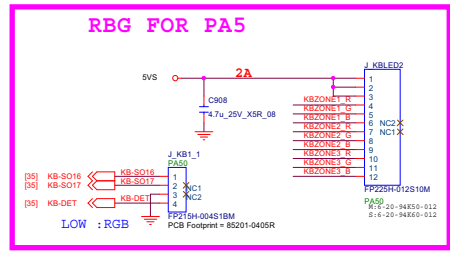
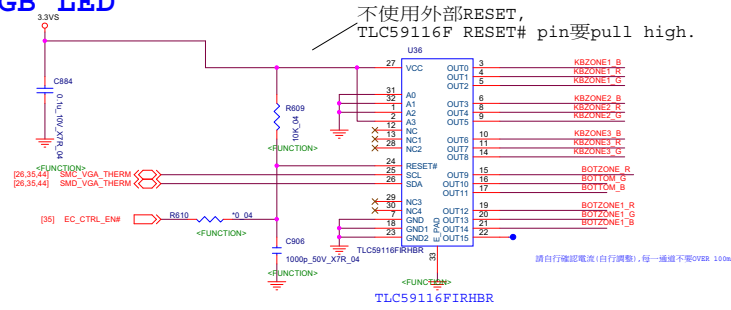

KEYBOARD WHITE LED

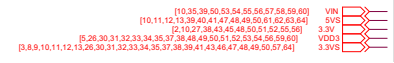
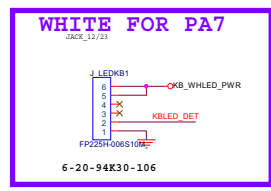
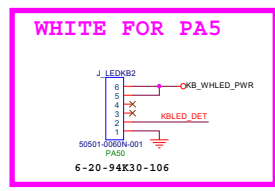
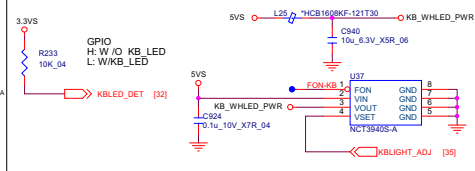

B.Schematic Diagrams

Sheet 36 of 77
RGB and White KB LED

M.2 PCIe4X SSD

Sheet 37 of 77
M.2 PCIe4X SSD

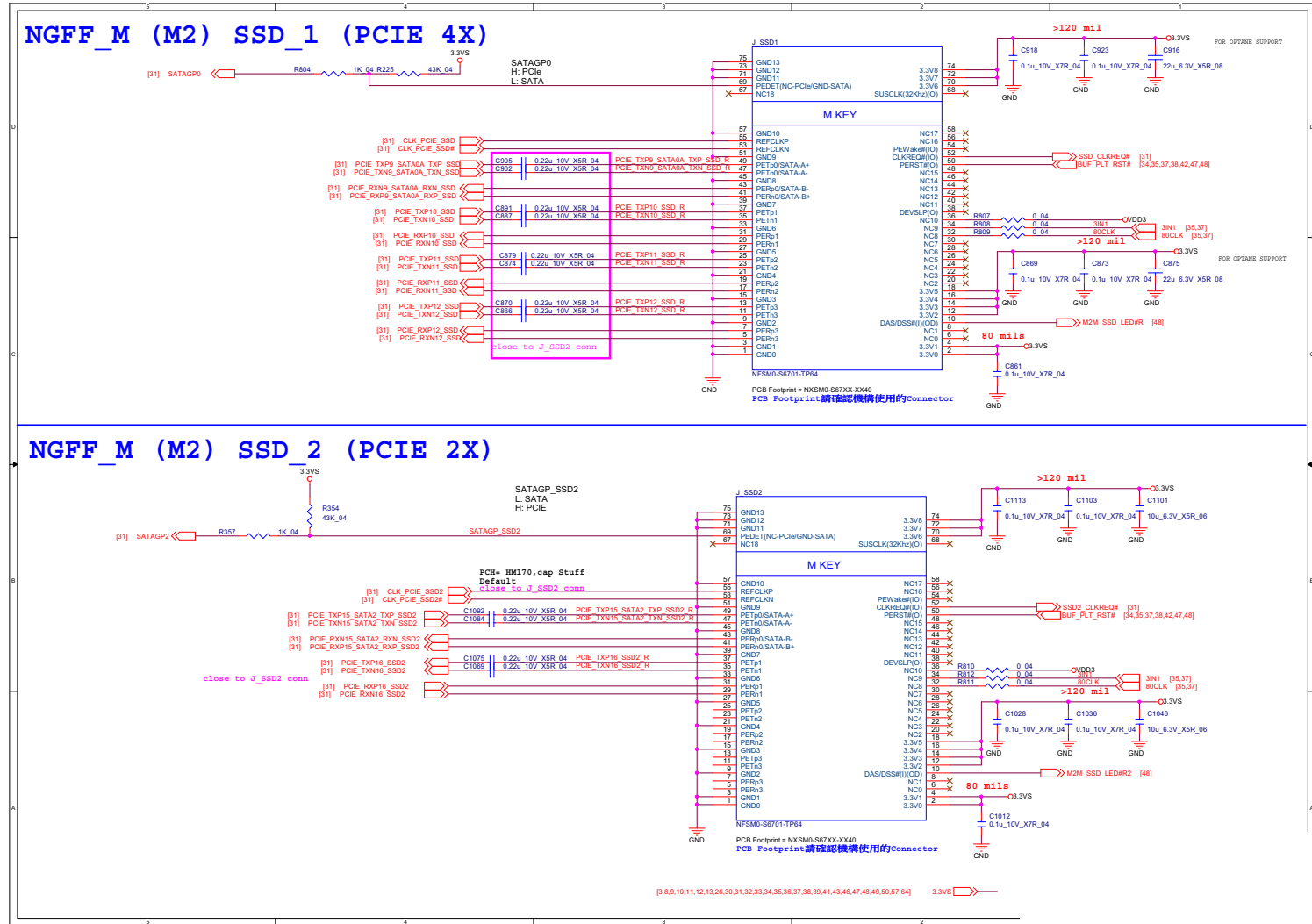

M.2 3G/LTE/WIGIG/WLAN+BT

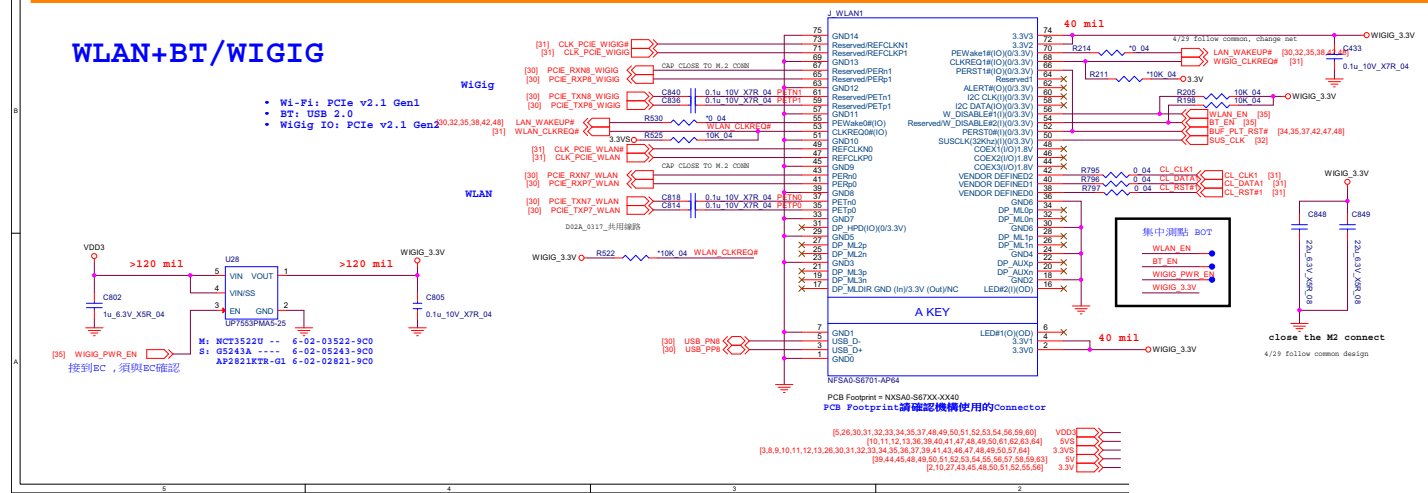
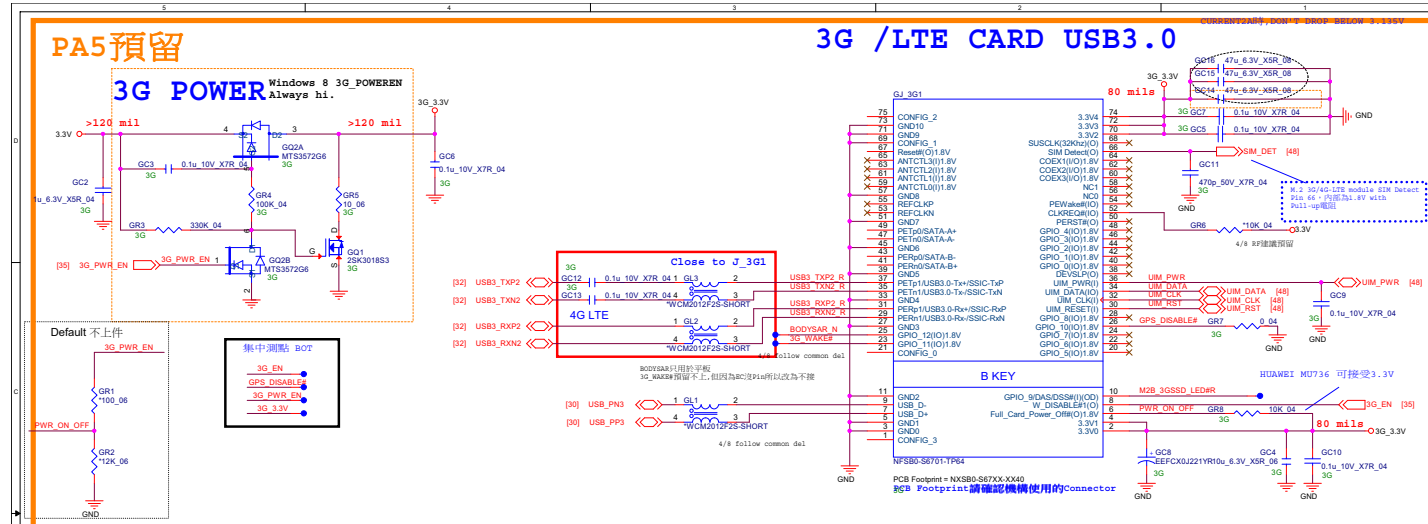

Sheet 38 of 77
M.2 3G/LTE/WIGIG/
WLAN+BT

B.Schematic Diagrams

Schematic Diagrams

Audio

Sheet 39 of 77
Audio

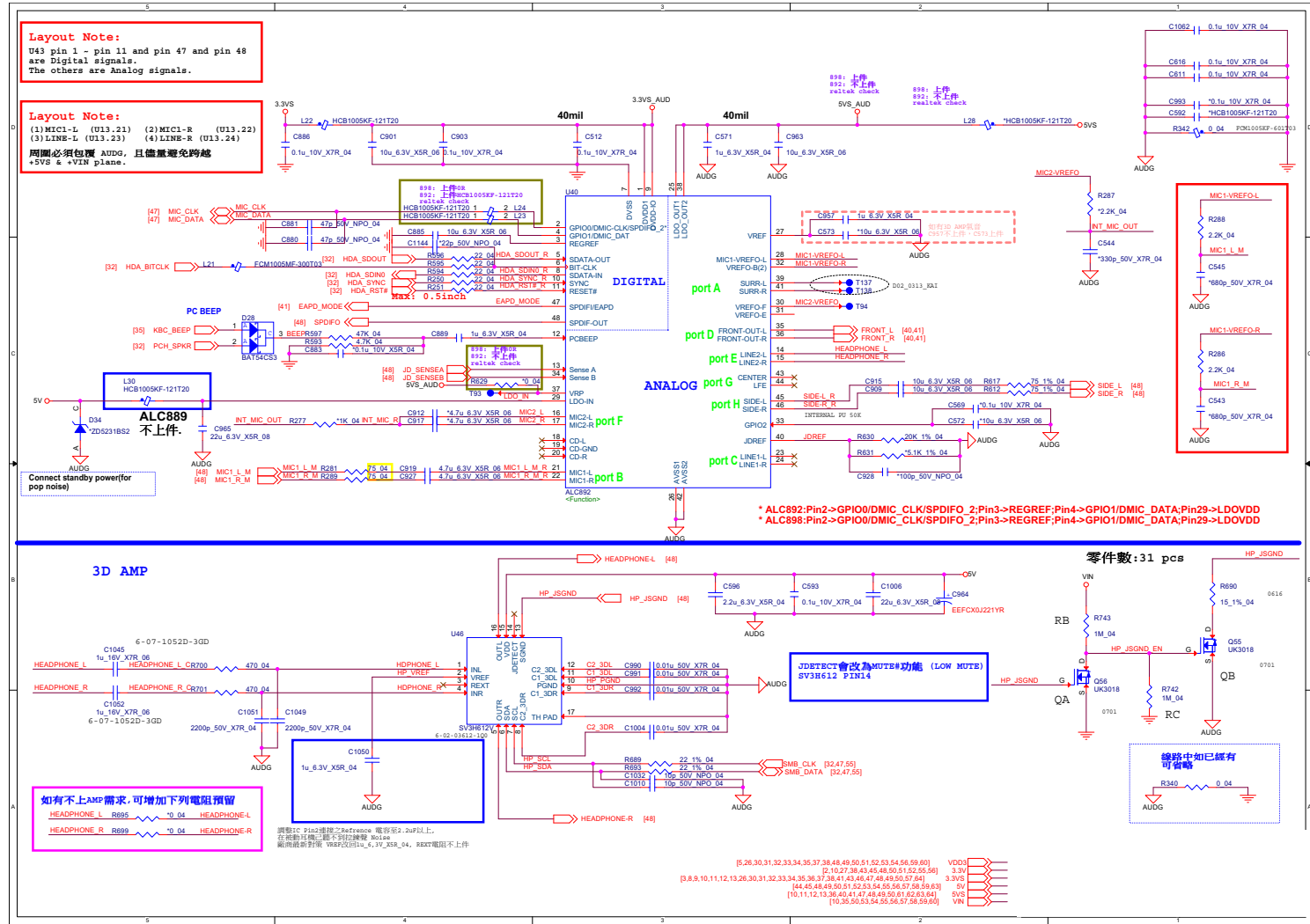

Audio Subwoofer

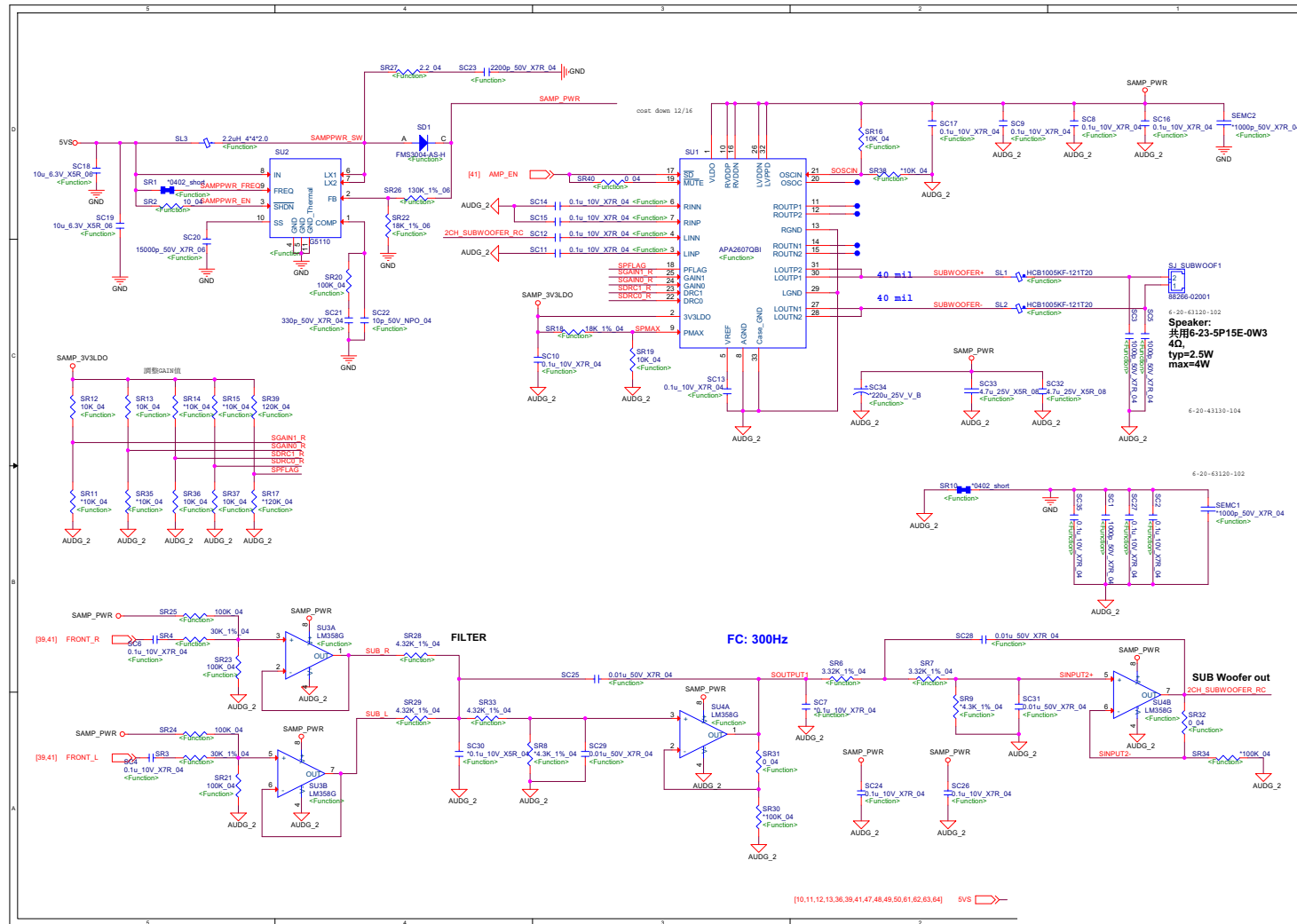

Sheet 40 of 77
Audio Subwoofer

B.Schematic Diagrams

Audio Port 1

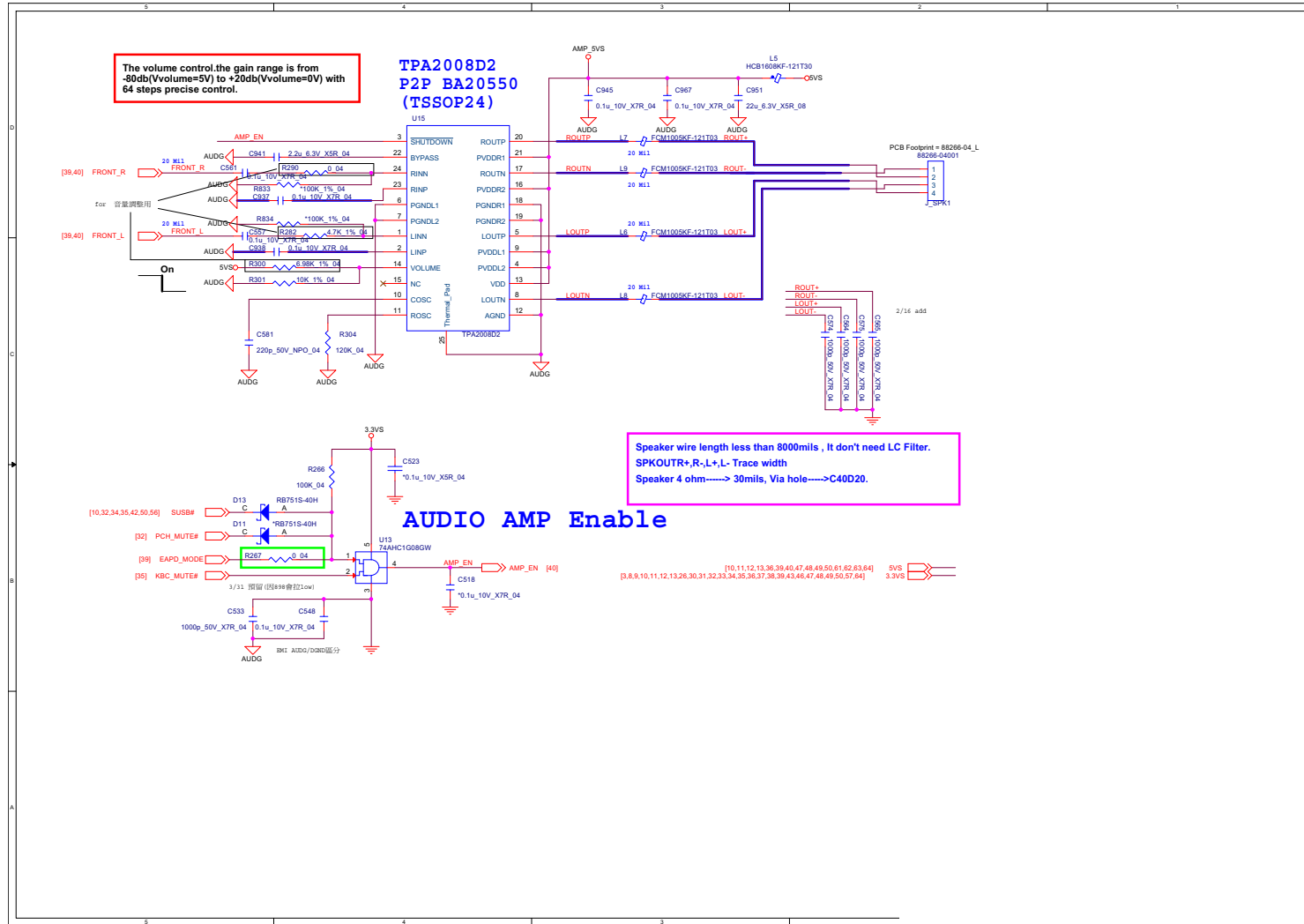

Sheet 41 of 77
Audio Port 1

B.Schematic Diagrams

AR_TBT

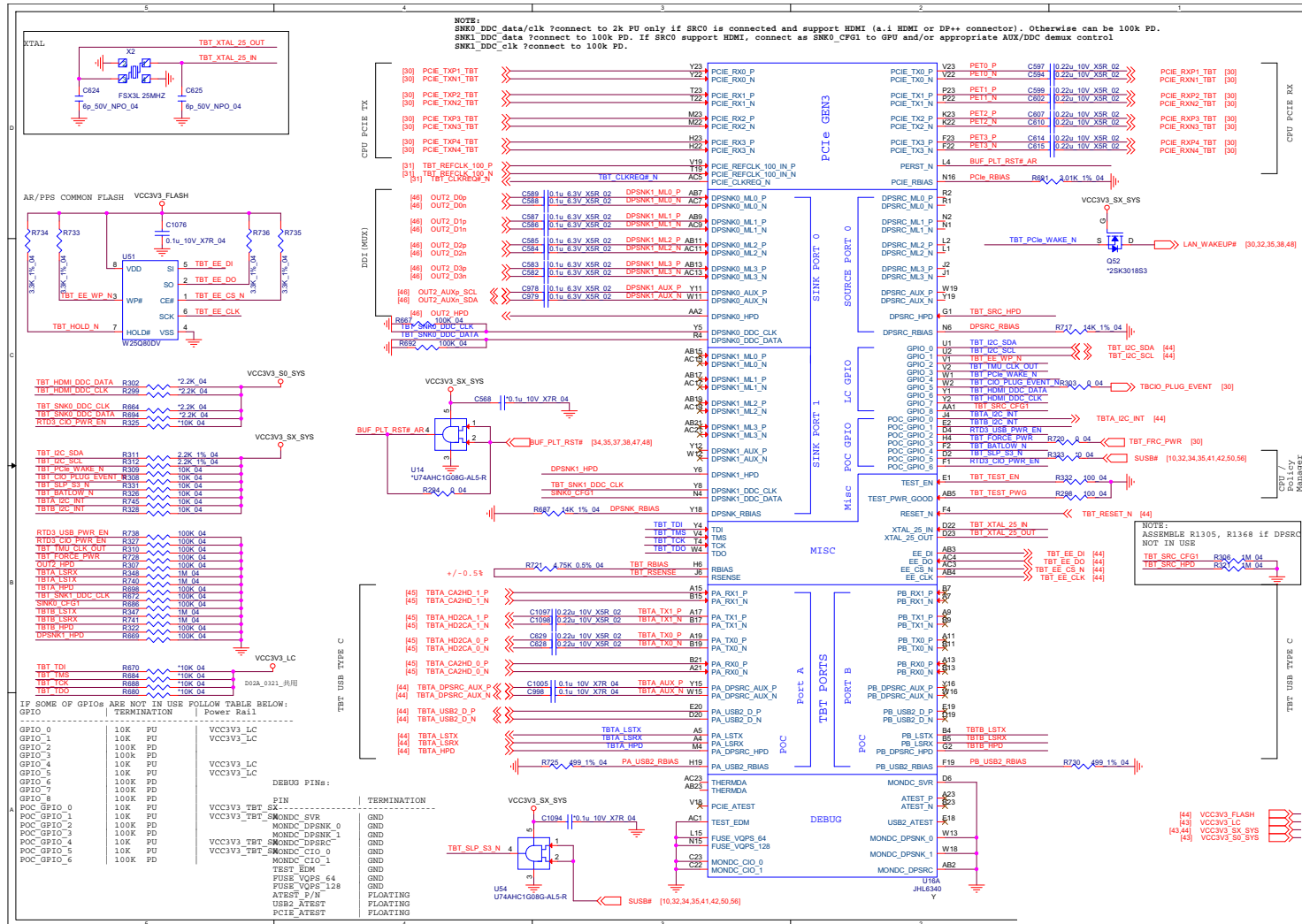

Sheet 42 of 77
AR_TBT

B.Schematic Diagrams

AR Power

Sheet 43 of 77
AR Power

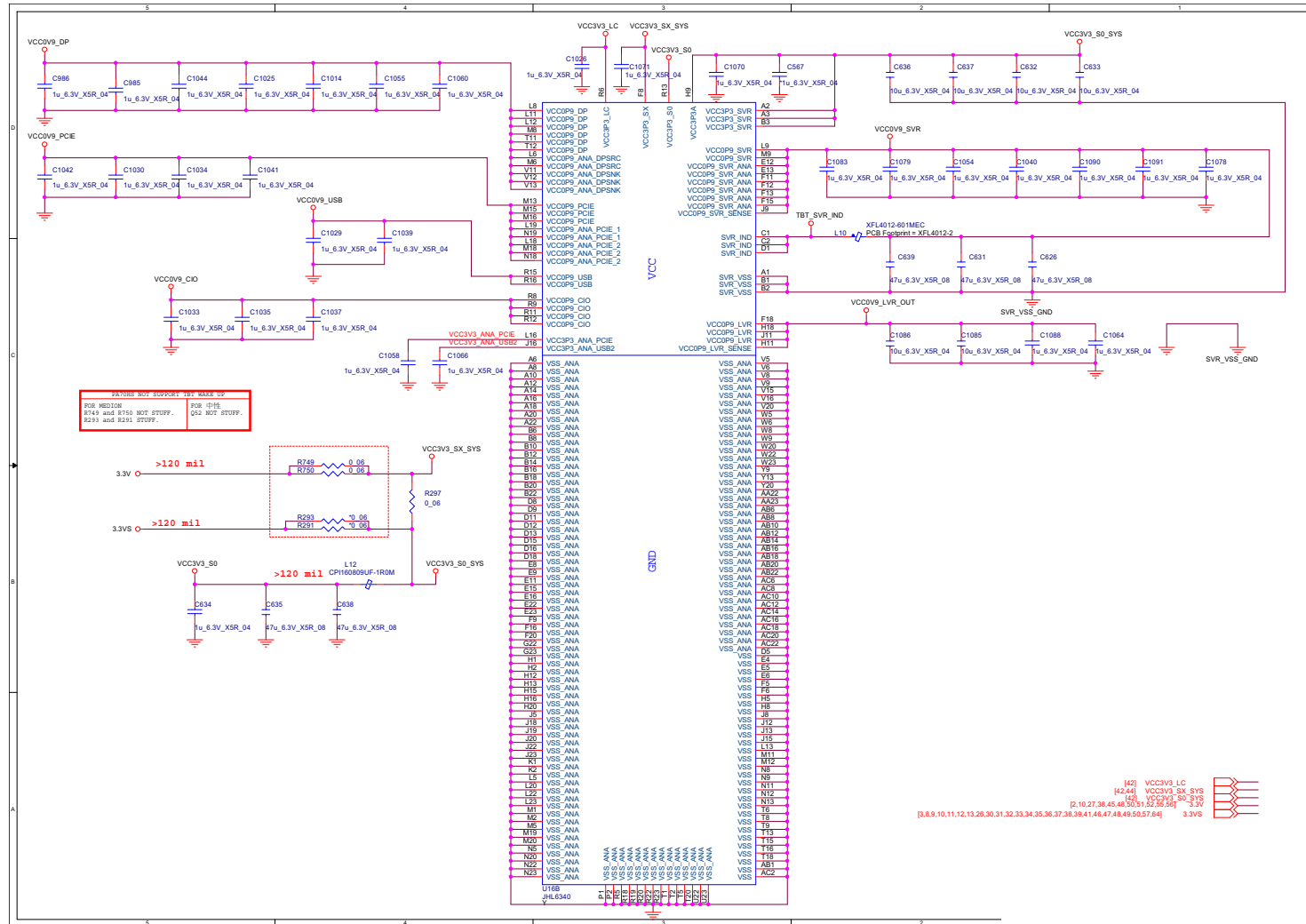

TPS65982ABZQZ

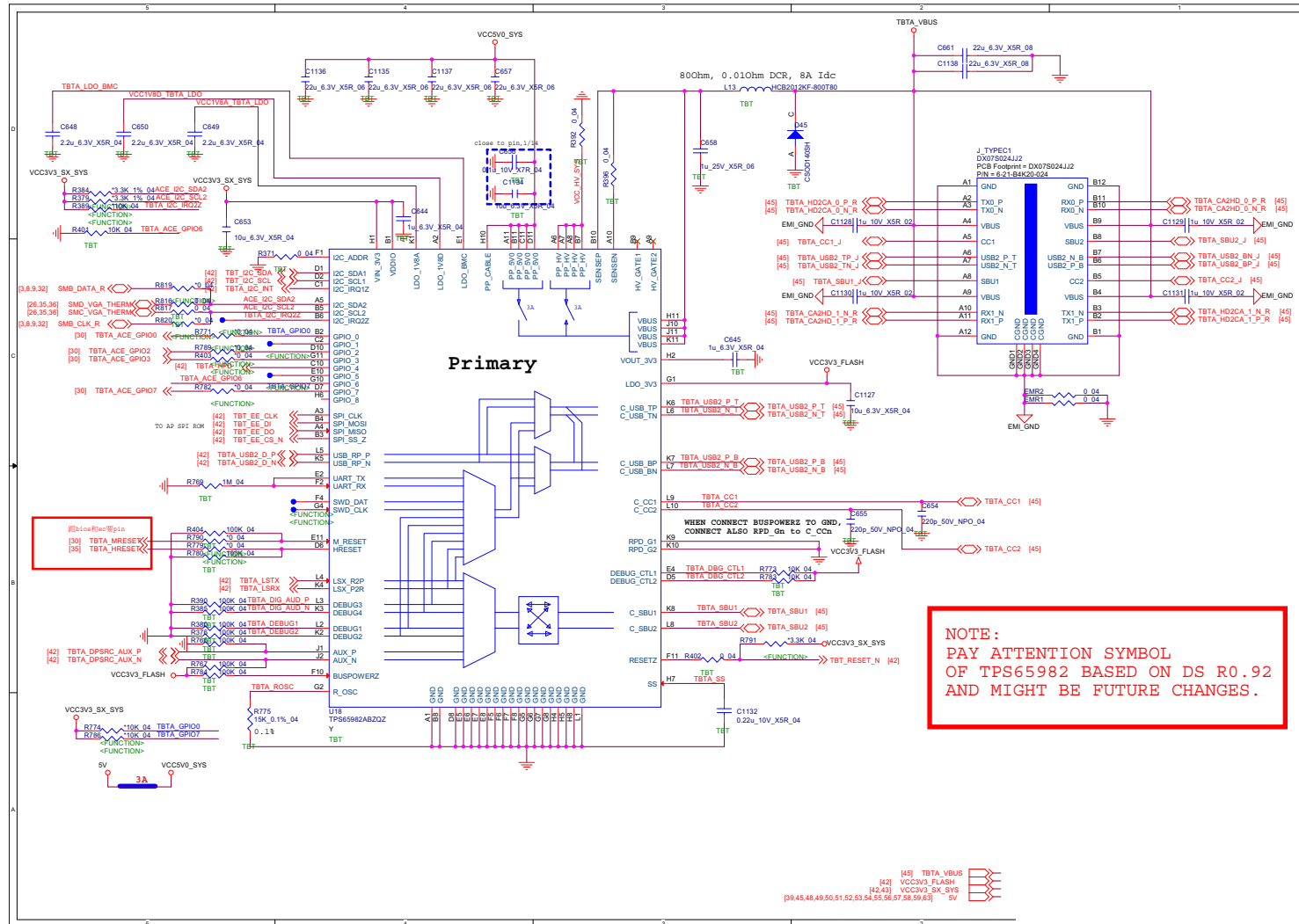

B.Schematic Diagrams

Sheet 44 of 77
 TPS65982ABZQZ

USB 3.0 Type C

Sheet 45 of 77
USB 3.0 Type C

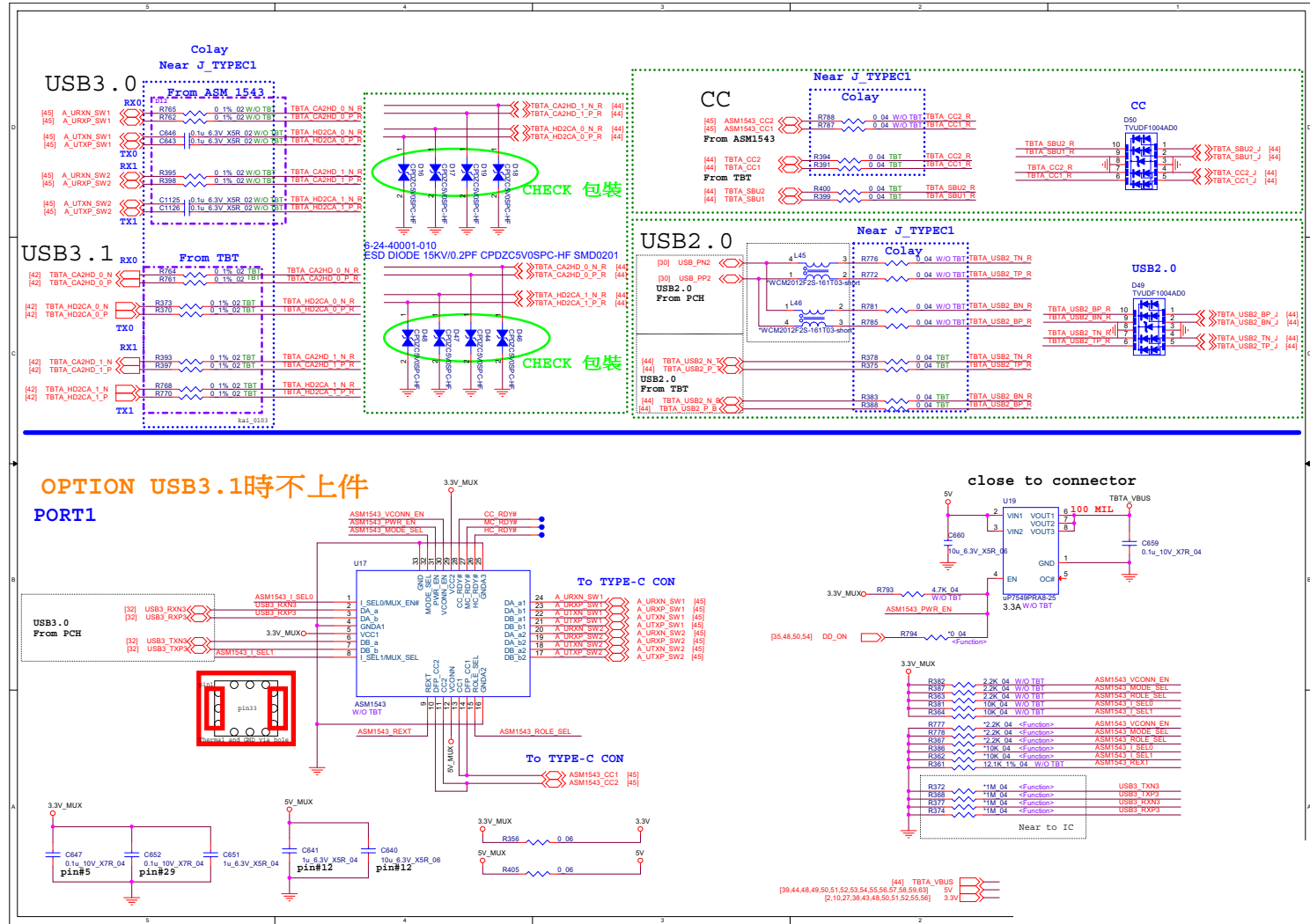

PS8338B

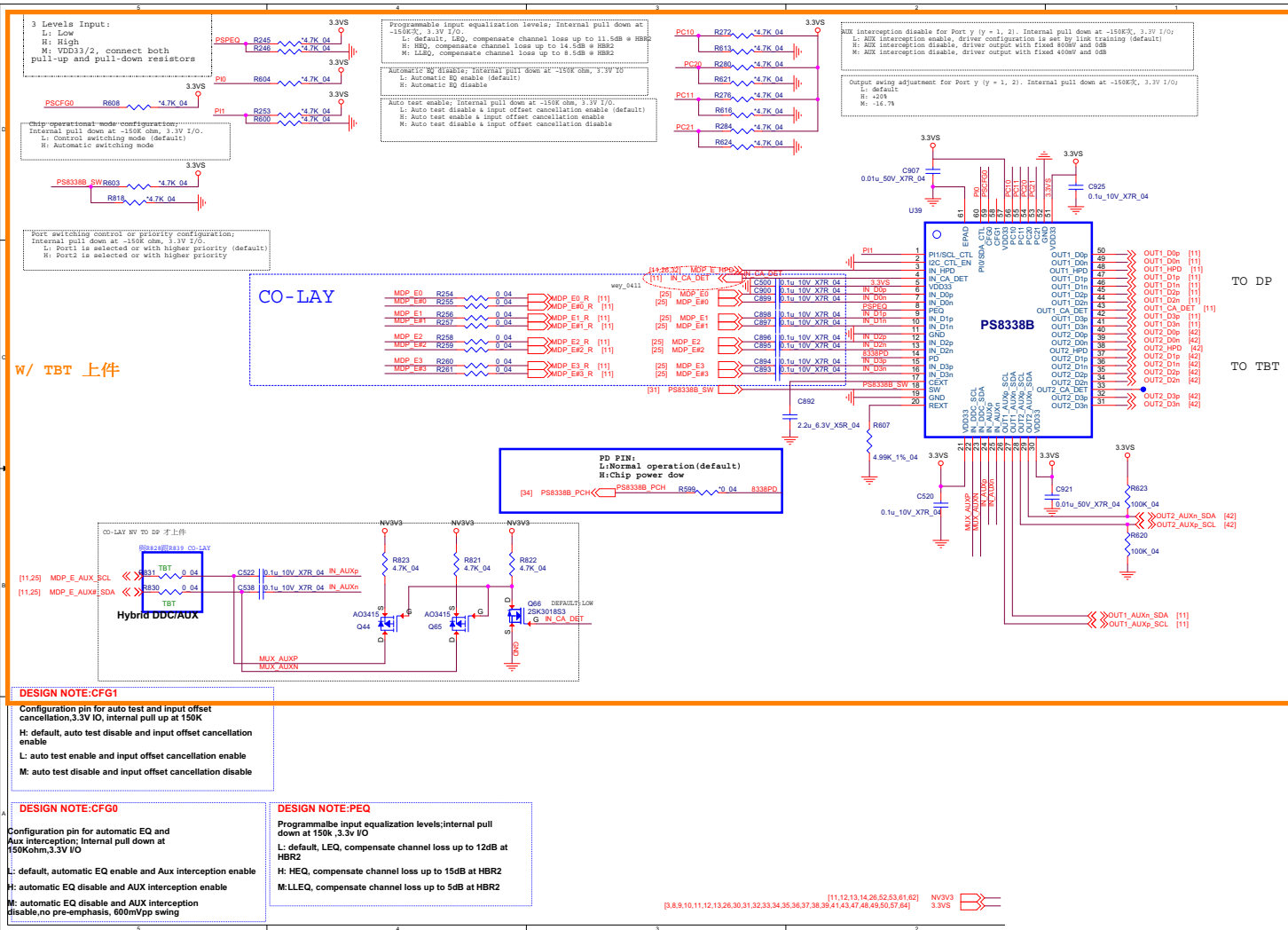

W/ TBT 上件

TO DP
TO TBT

Sheet 46 of 77
PS8338B

B.Schematic Diagrams

TPM, CCD, TP

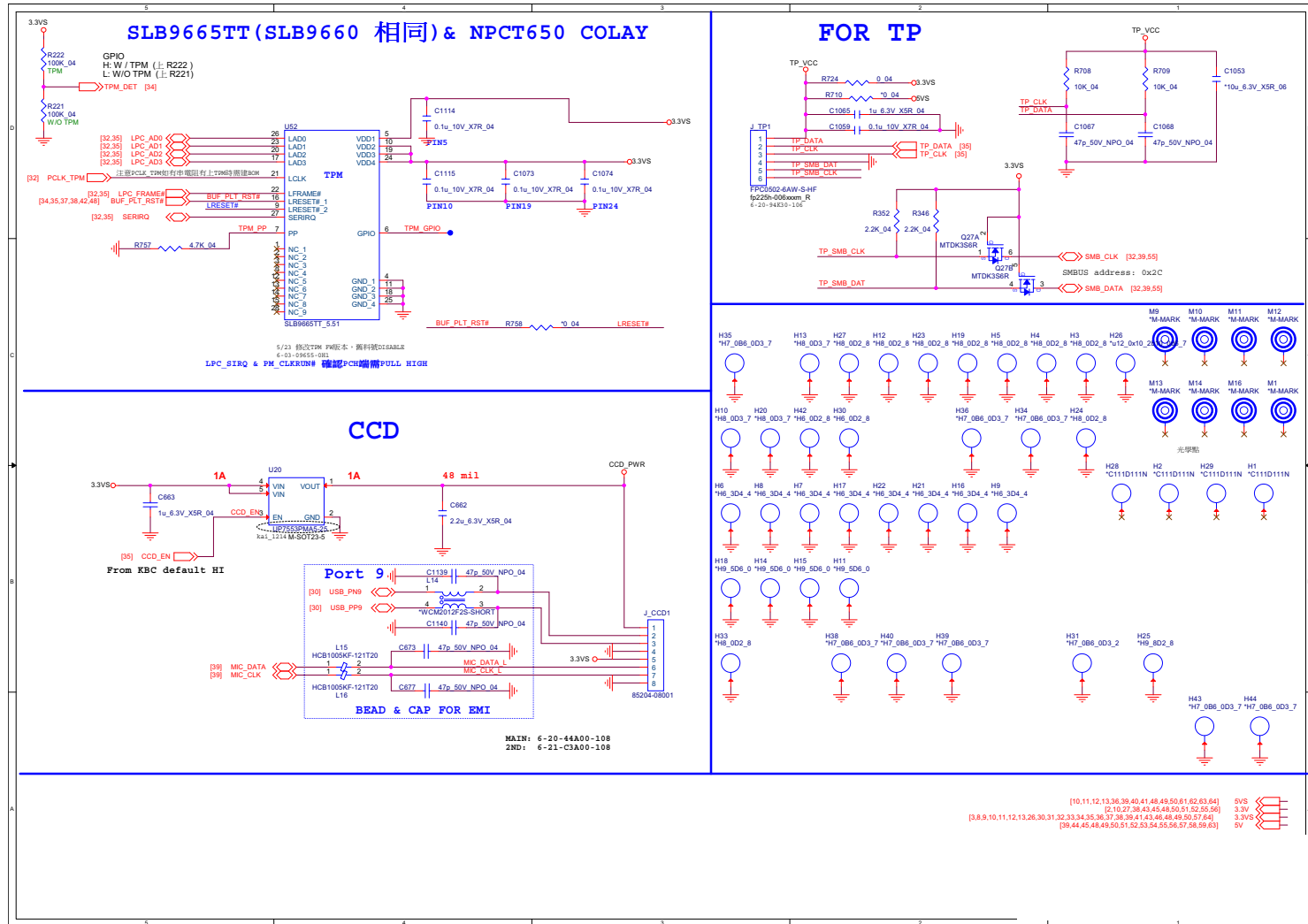

B.Schematic Diagrams

Connectors

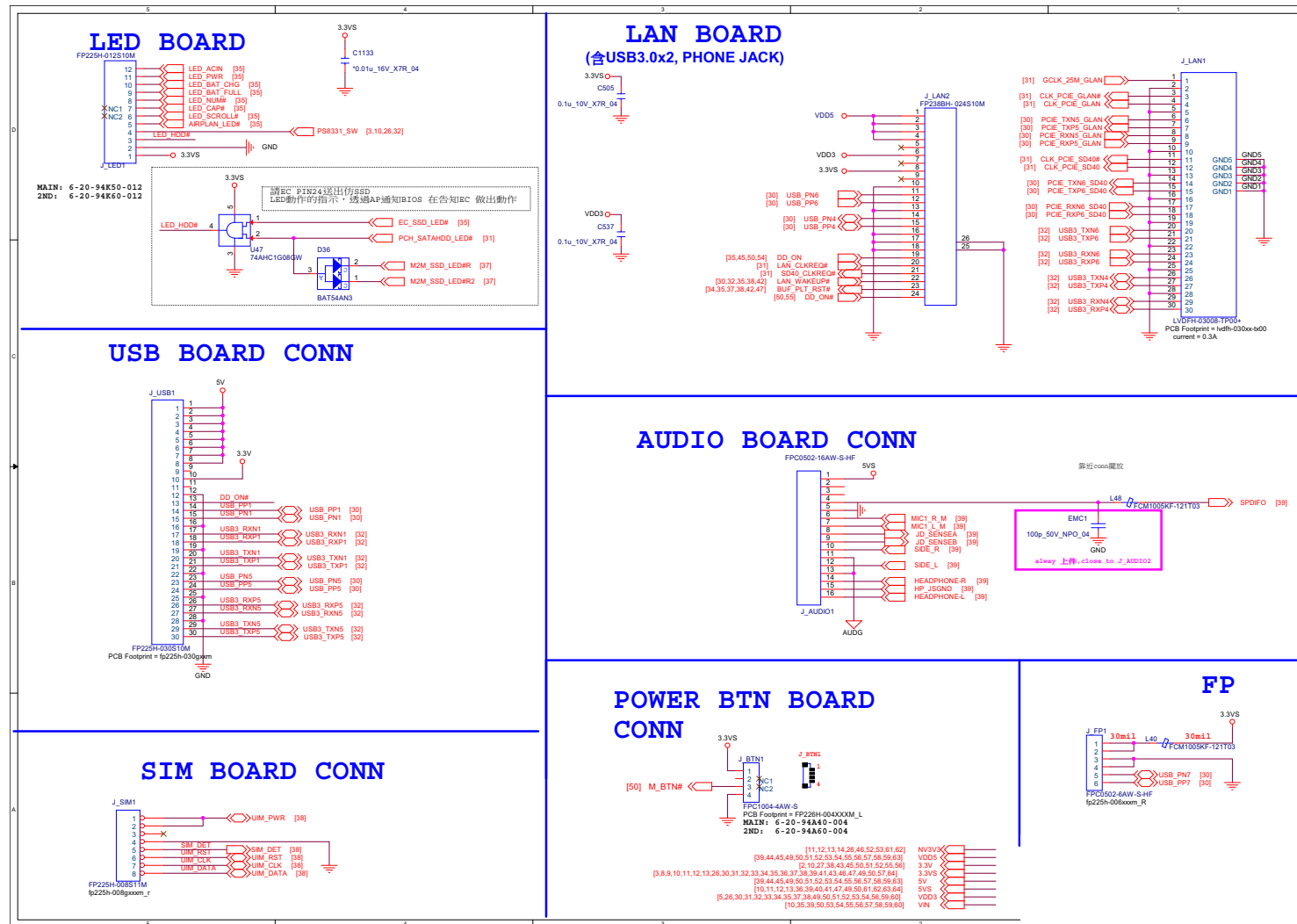

Sheet 48 of 77
Connectors

B.Schematic Diagrams

5V, 5VS, 3.3V, 3.3VS, 3.3VA

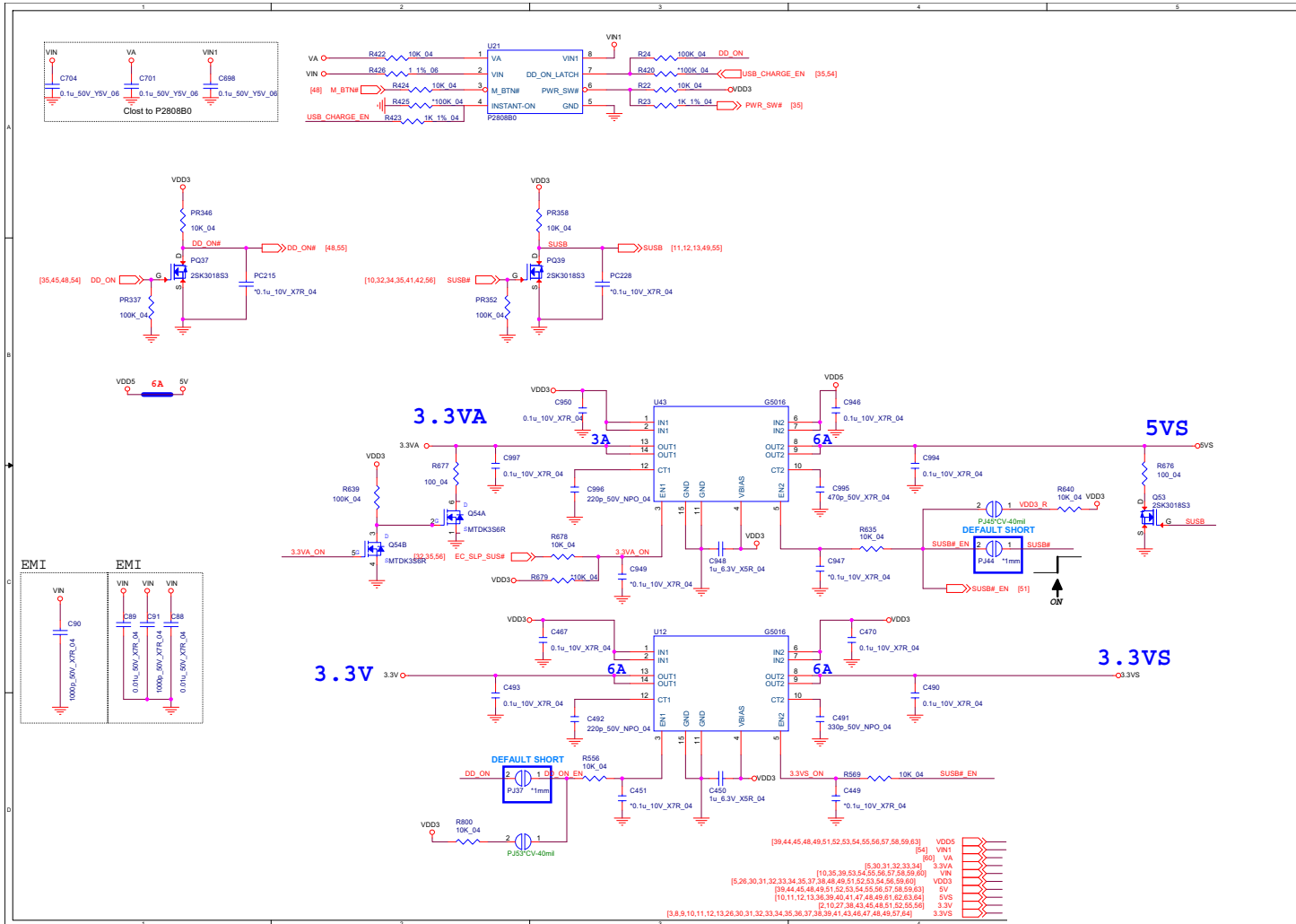

Sheet 50 of 77
5V, 5VS, 3.3V,
3.3VS, 3.3VA

B.Schematic Diagrams

Schematic Diagrams

1.0DX_VCCSTG/VCCSFR_OC/2.5V

Sheet 51 of 77
1.0DX_VCCSTG/
VCCSFR_OC/2.5V

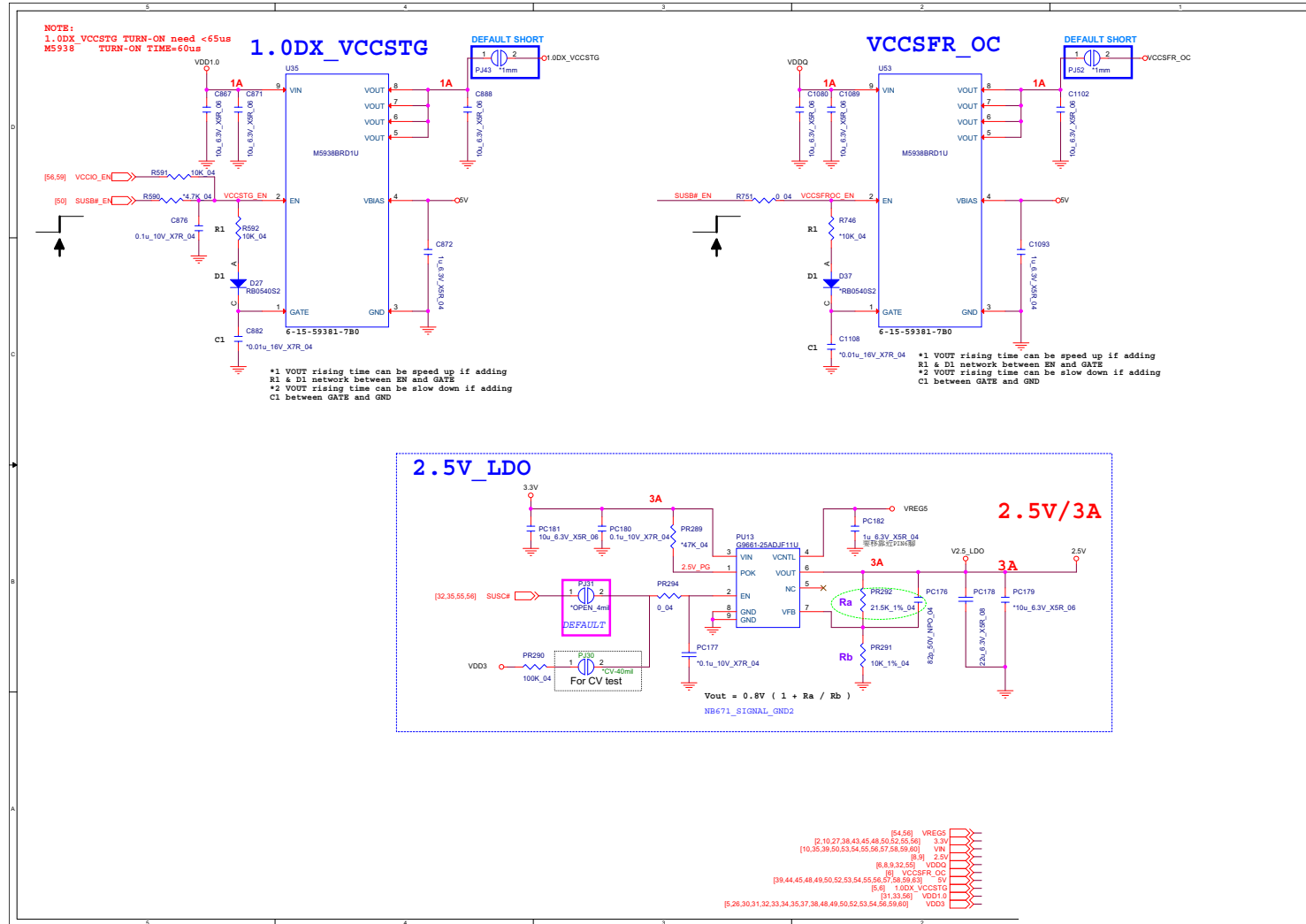

1V8_RUN/AON, NV3V3

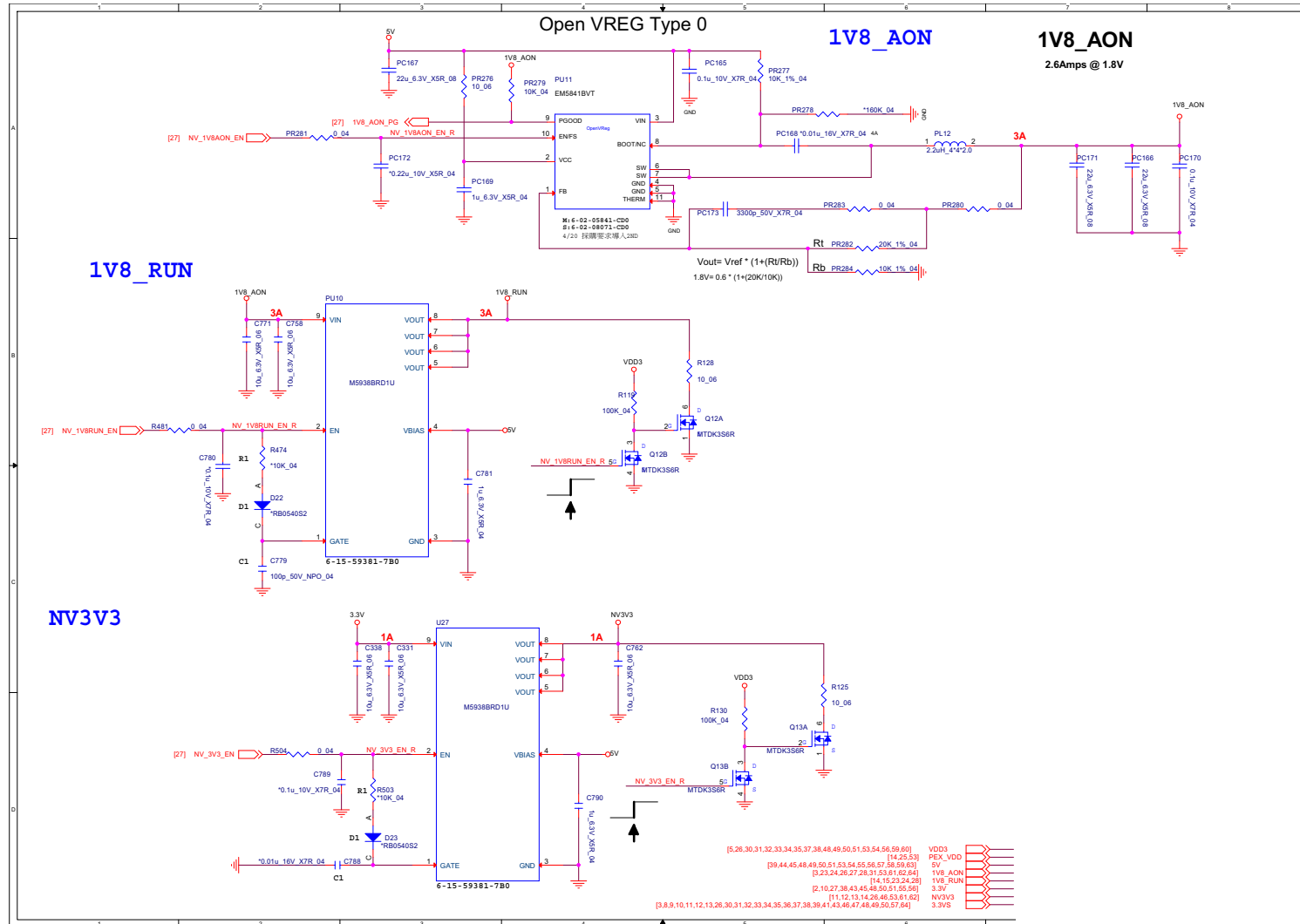

Sheet 52 of 77
1V8_RUN/AON,
NV3V3

PEX_VDD

Sheet 53 of 77
PEX_VDD

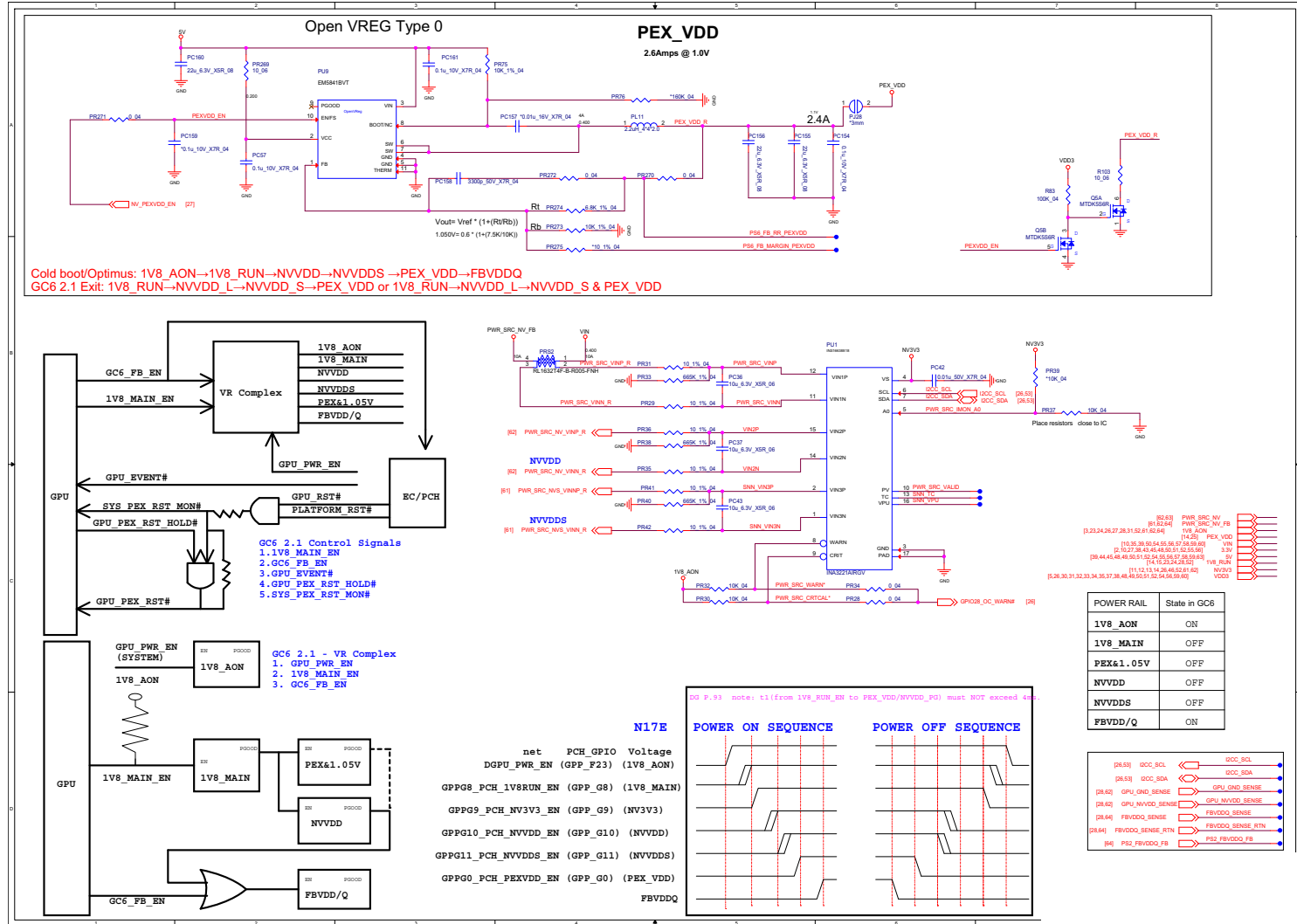

VDD3, VDD5

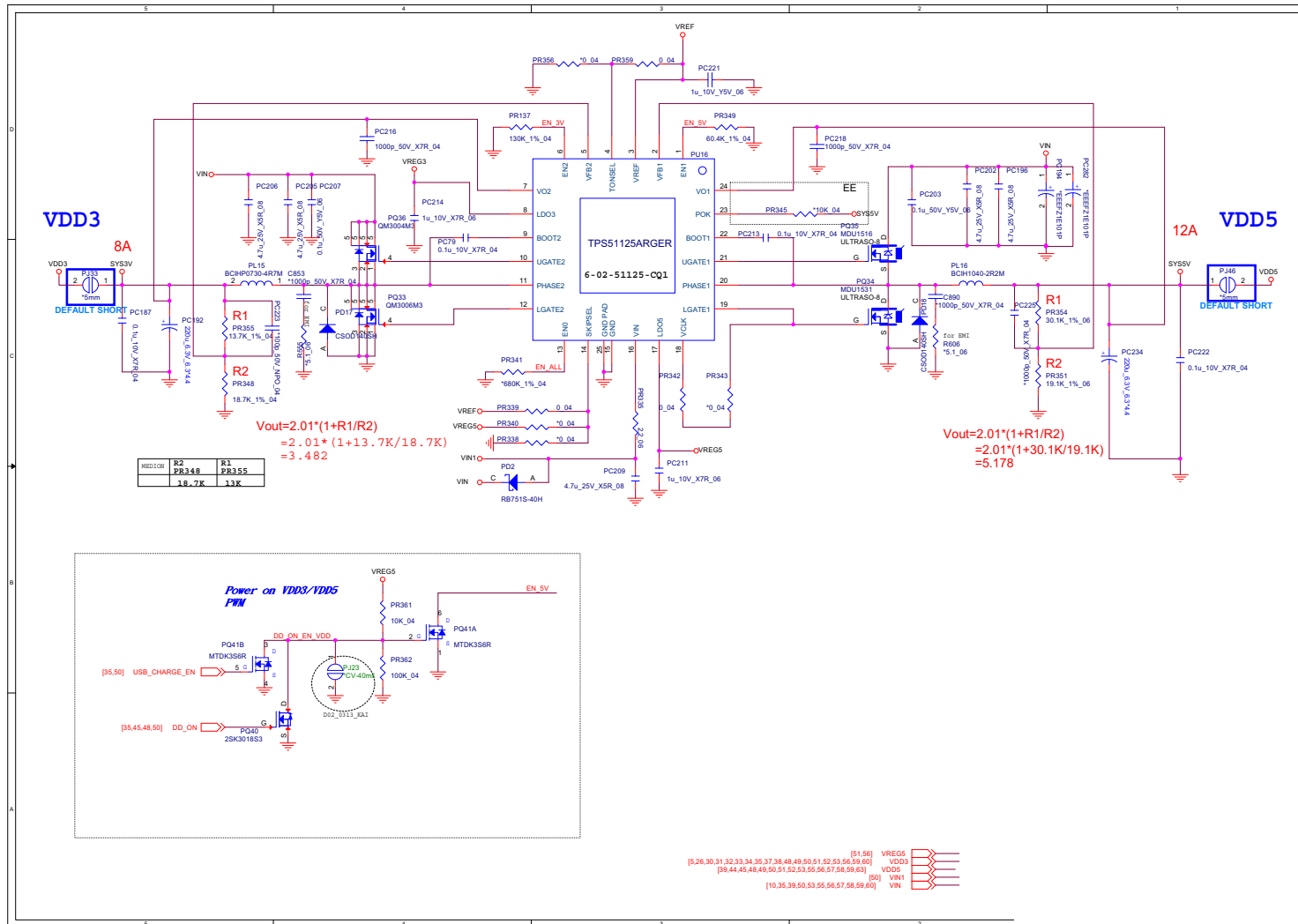

Sheet 54 of 77
VDD3, VDD5

Schematic Diagrams

DDR 1.2V / 0.6VS

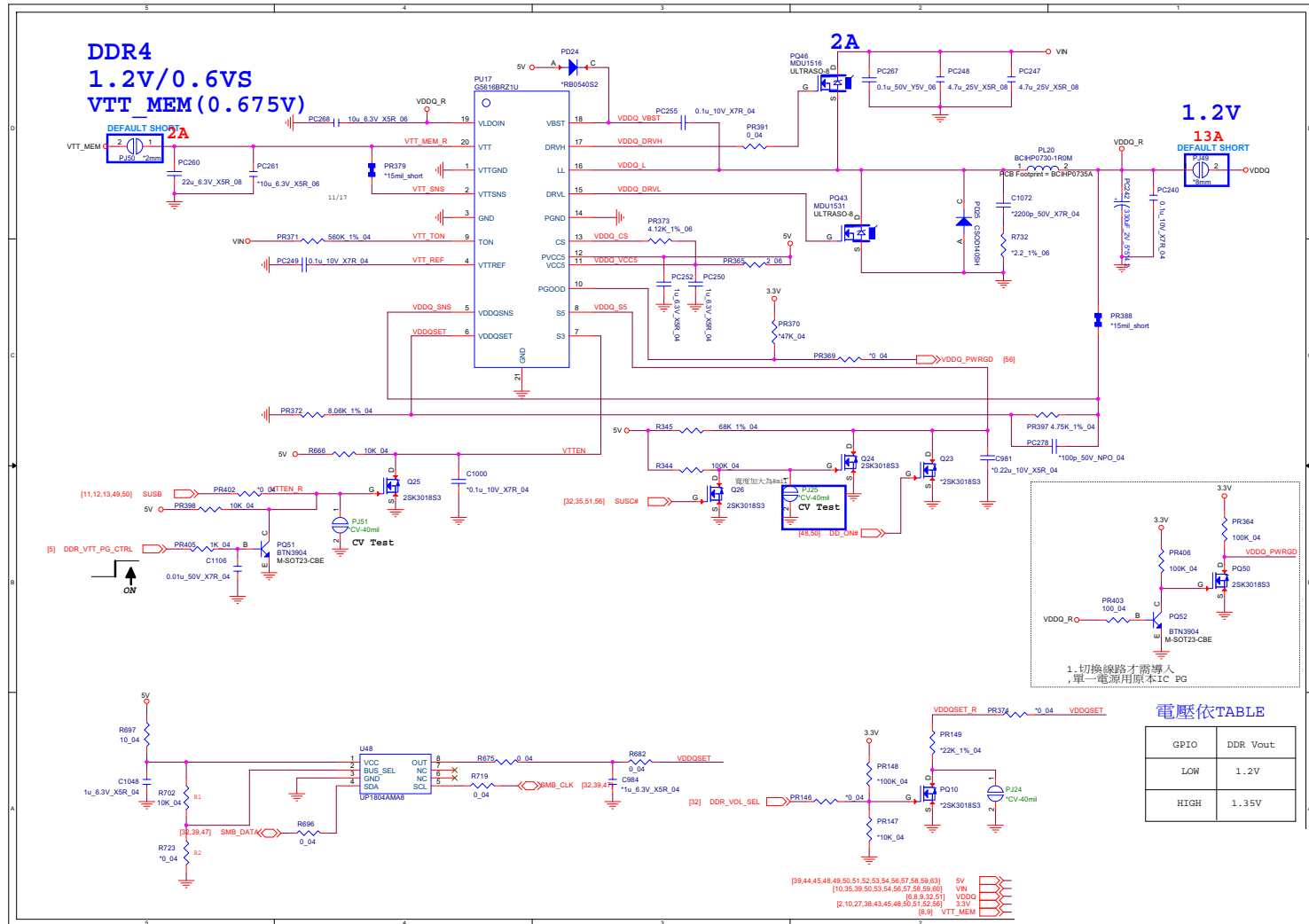

GPIO	DDR_Vout
LOW	1.2V
HIGH	1.35V

B.Schematic Diagrams

Sheet 55 of 77
DDR 1.2V / 0.6VS

Power 1.0V, VCCIO

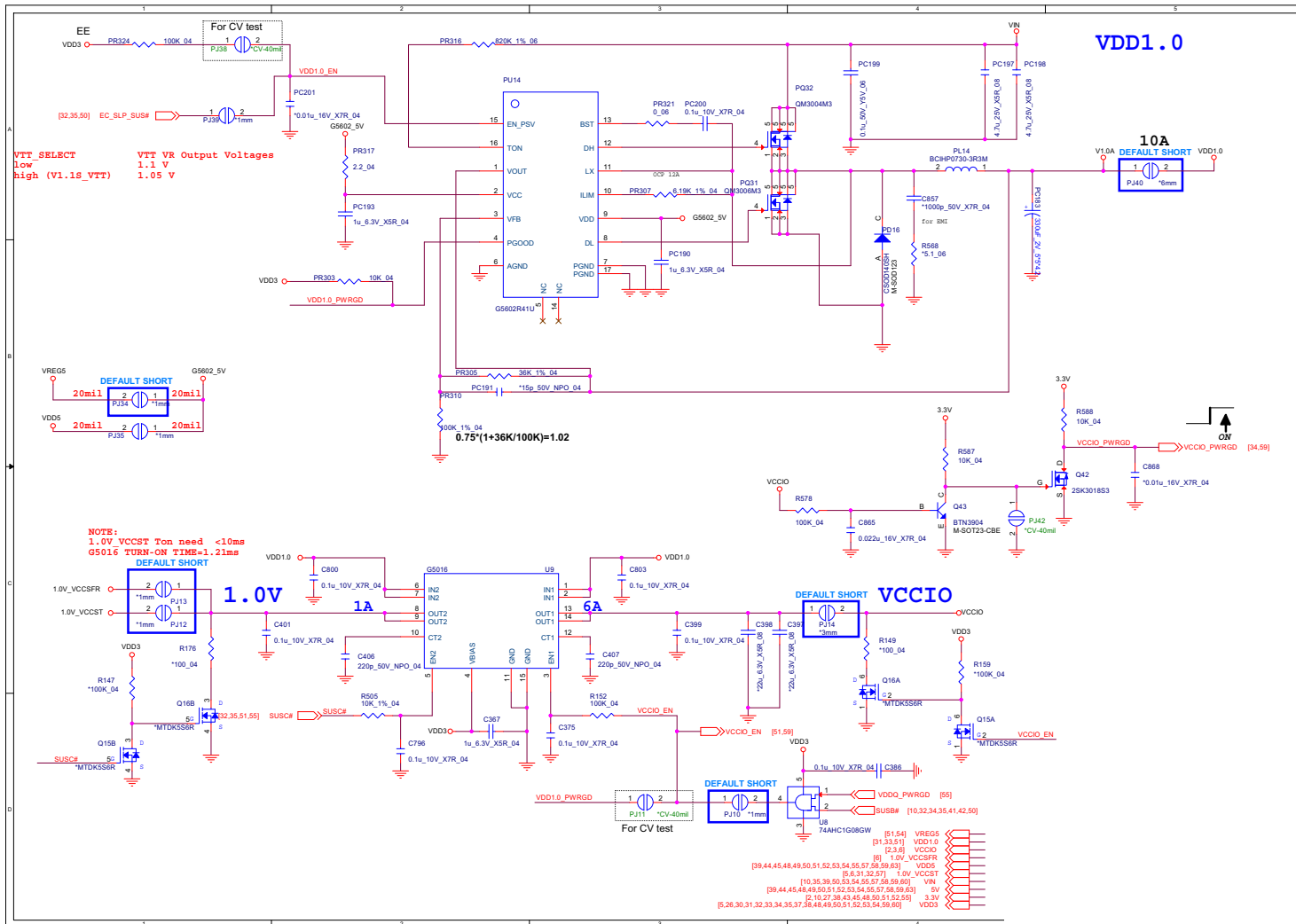

Sheet 56 of 77
Power 1.0V, VCCIO

B.Schematic Diagrams

VCore & VCCGT Output

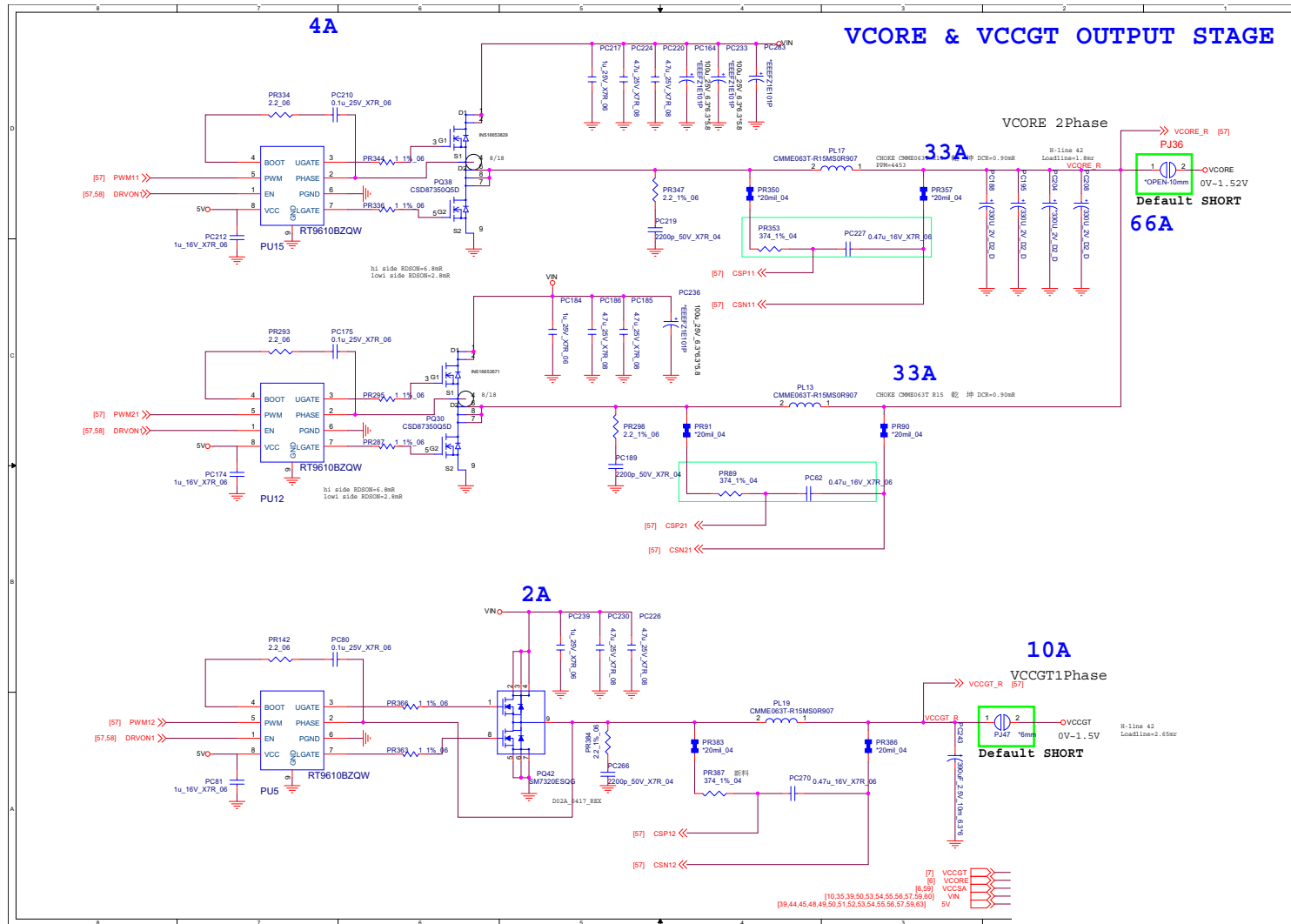

Sheet 58 of 77
VCore & VCCGT
Output

B.Schematic Diagrams

Schematic Diagrams

VCCSA

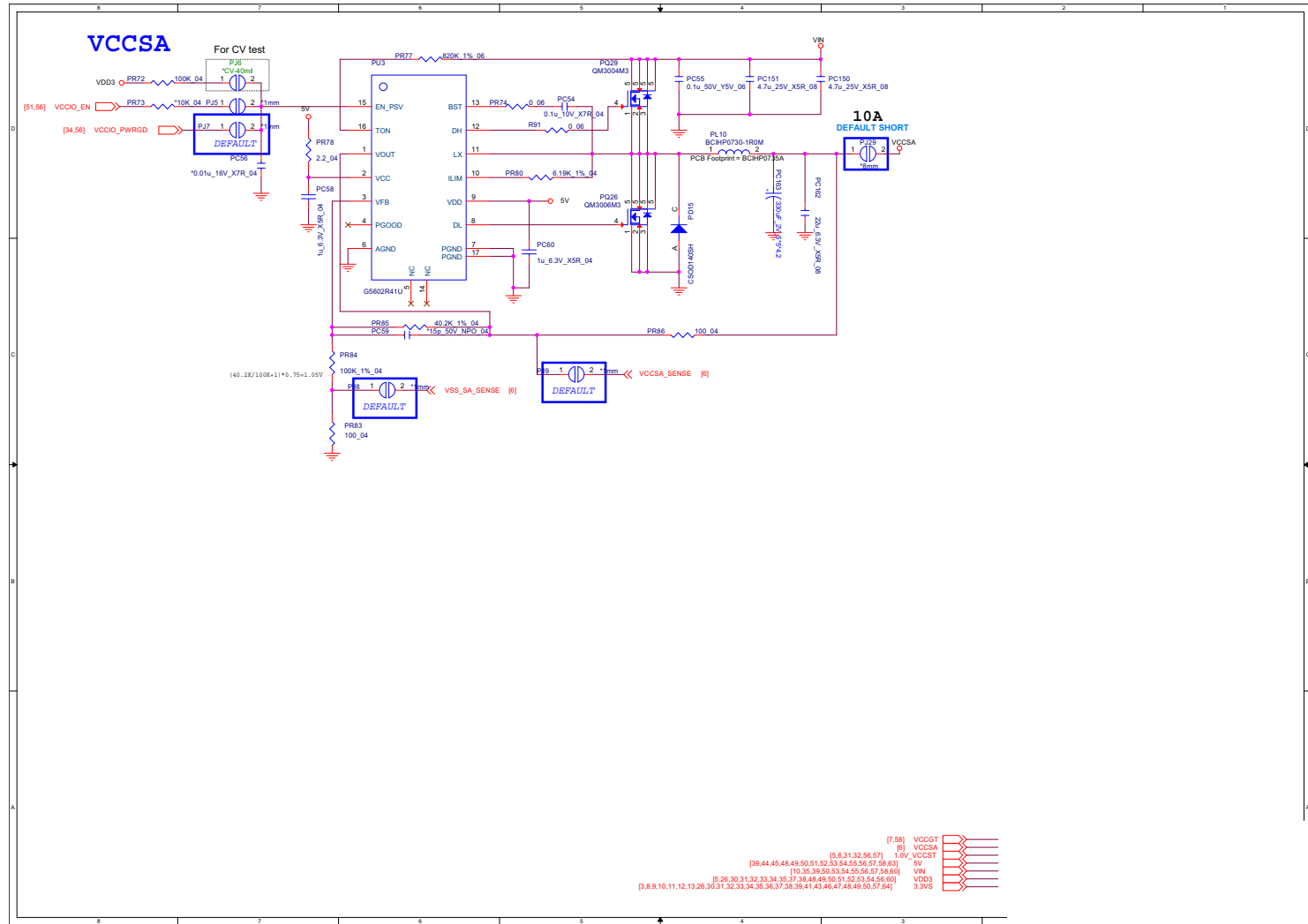

Sheet 59 of 77
VCCSA

AC_In, Charger

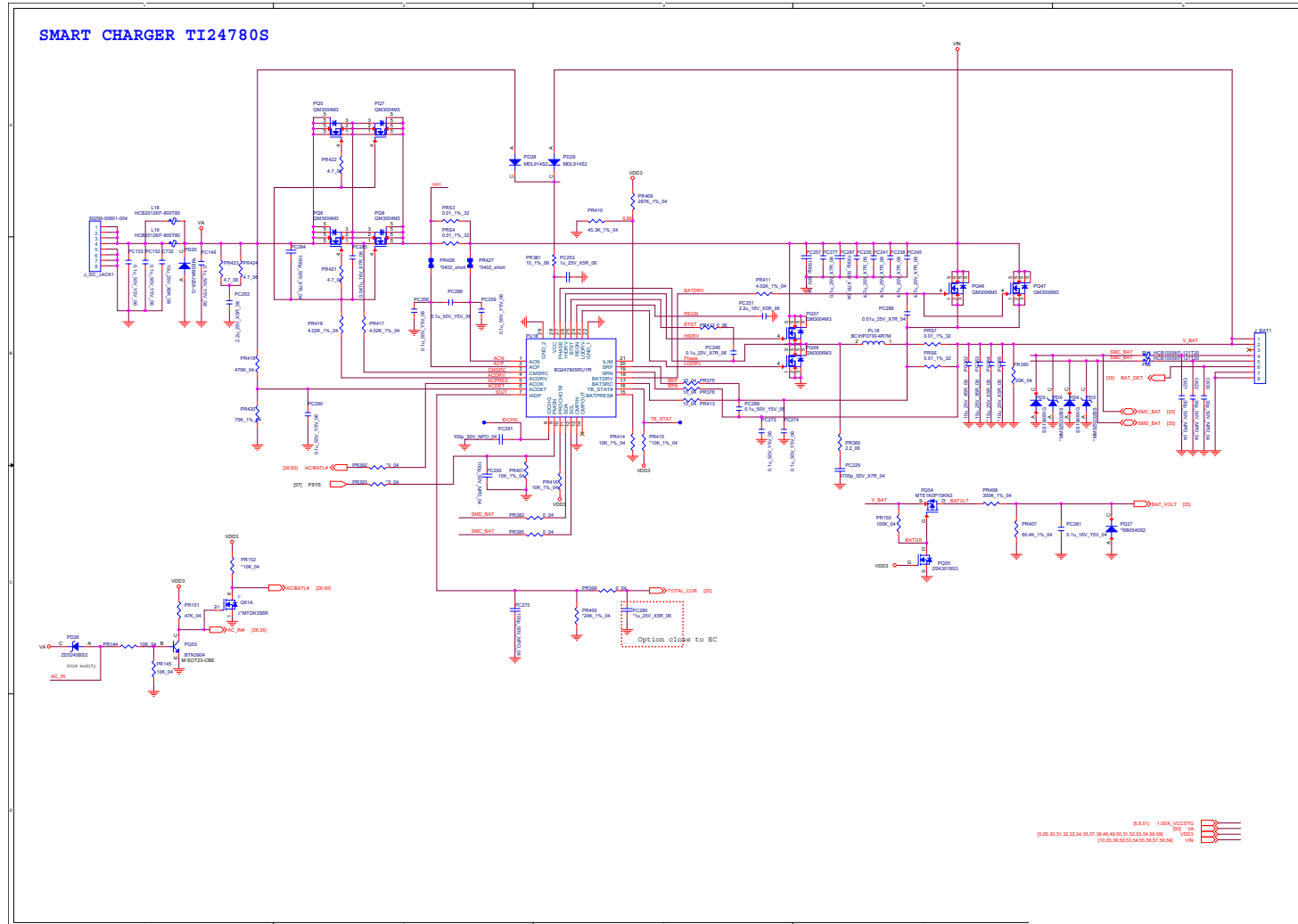

Sheet 60 of 77
AC_In, Charger

B.Schematic Diagrams

NVVDOS

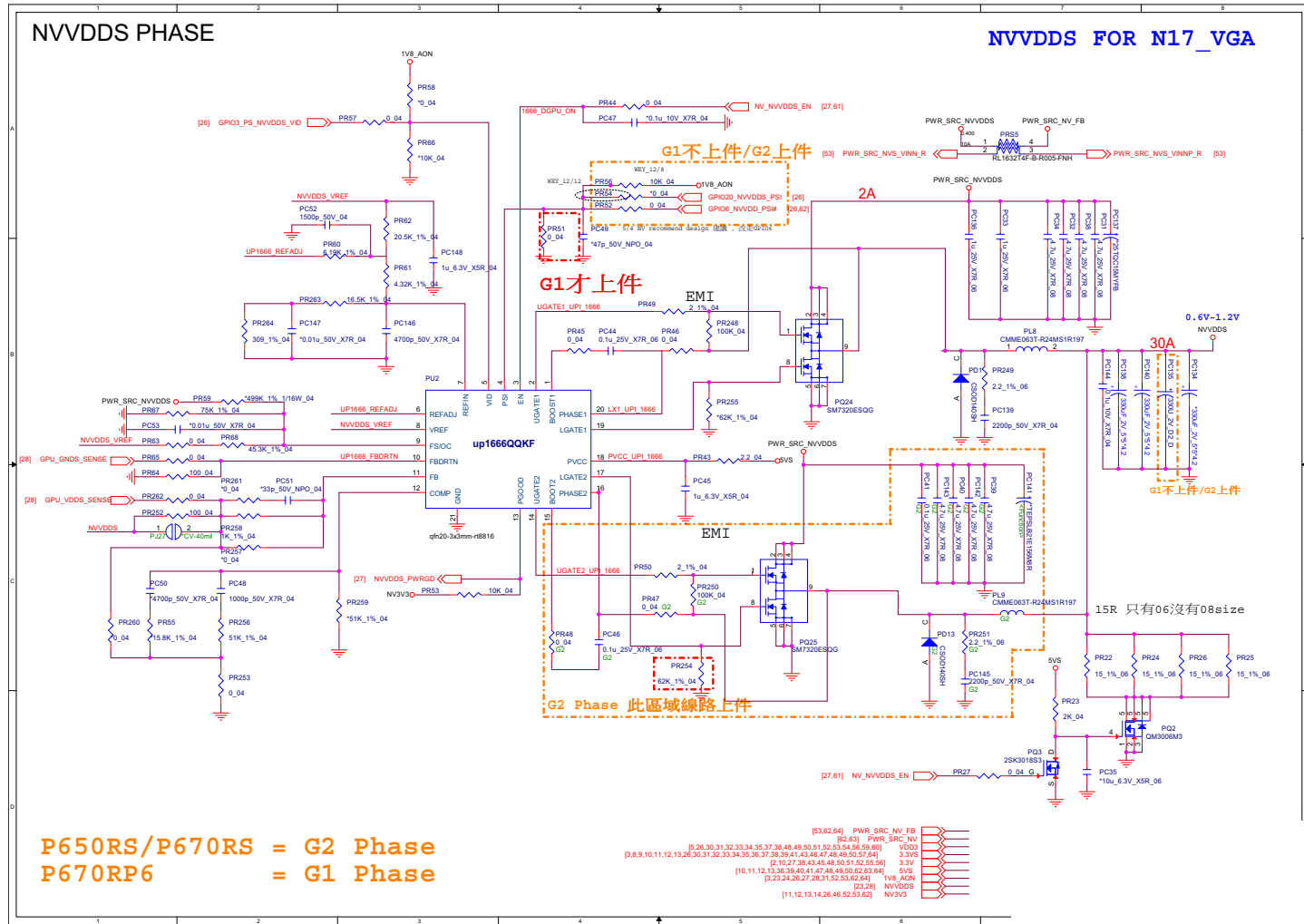

NVDD 1

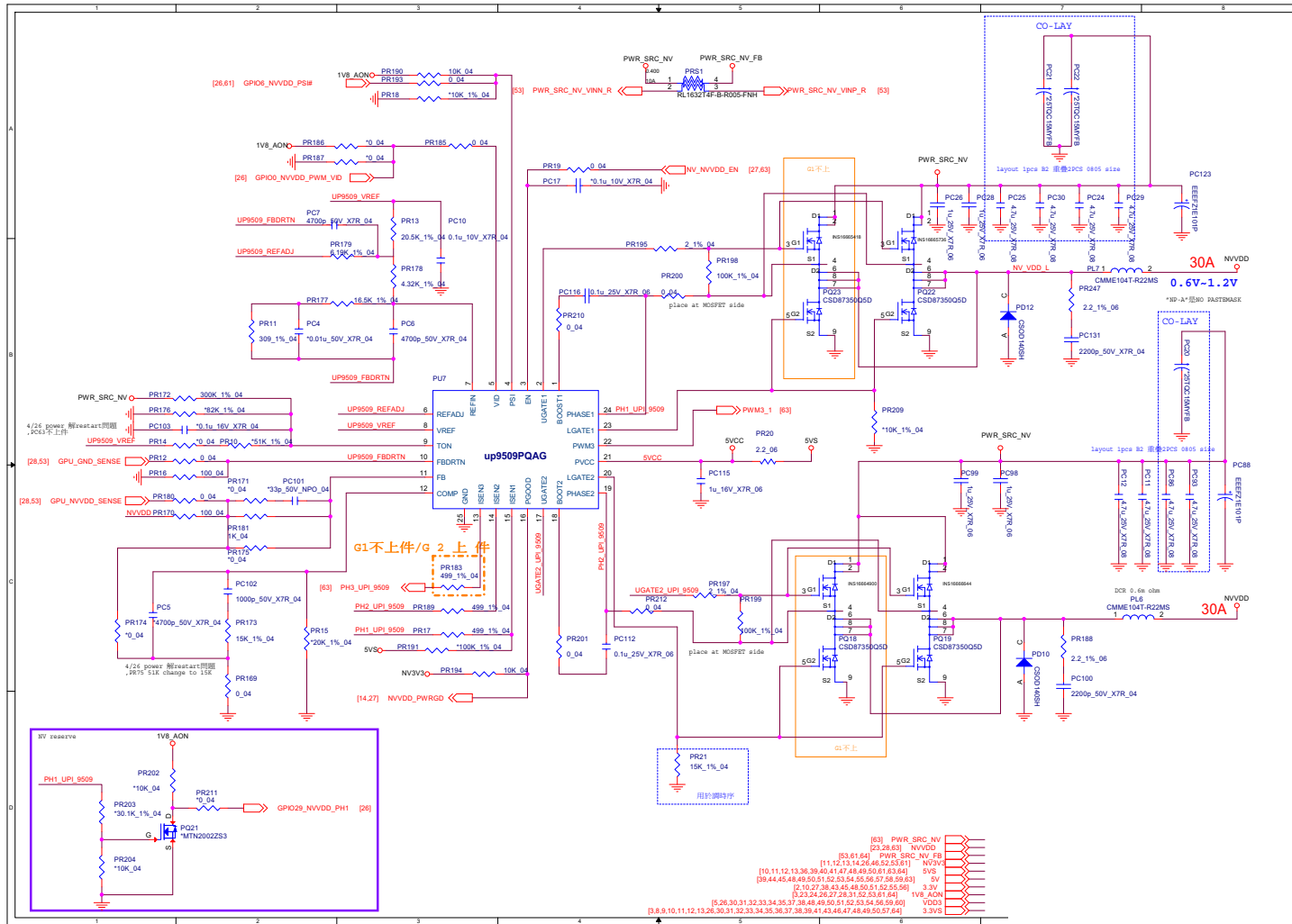

Sheet 62 of 77
NVDD 1

B.Schematic Diagrams

NVDD 2

Sheet 63 of 77
NVDD 2

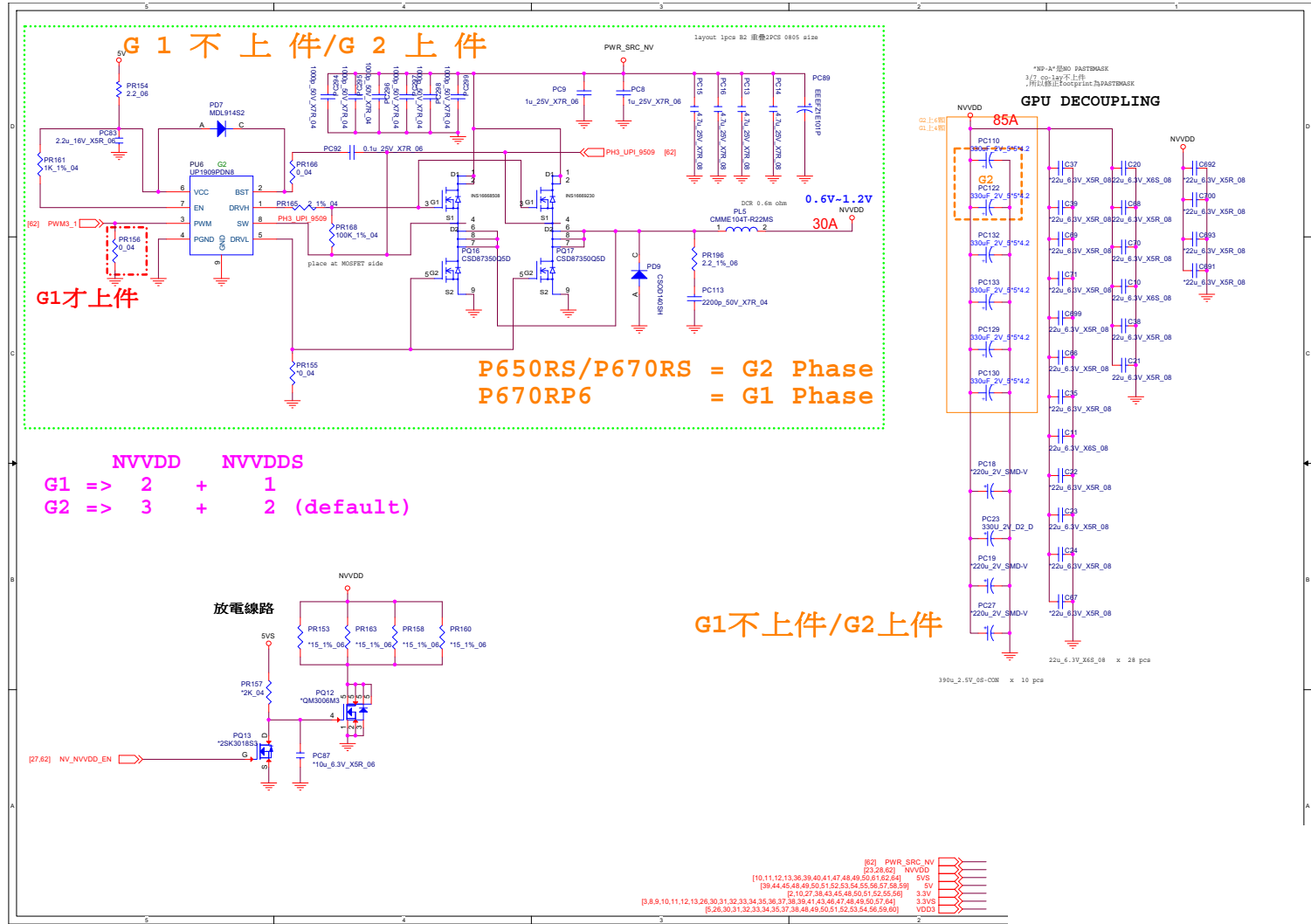

LED Board

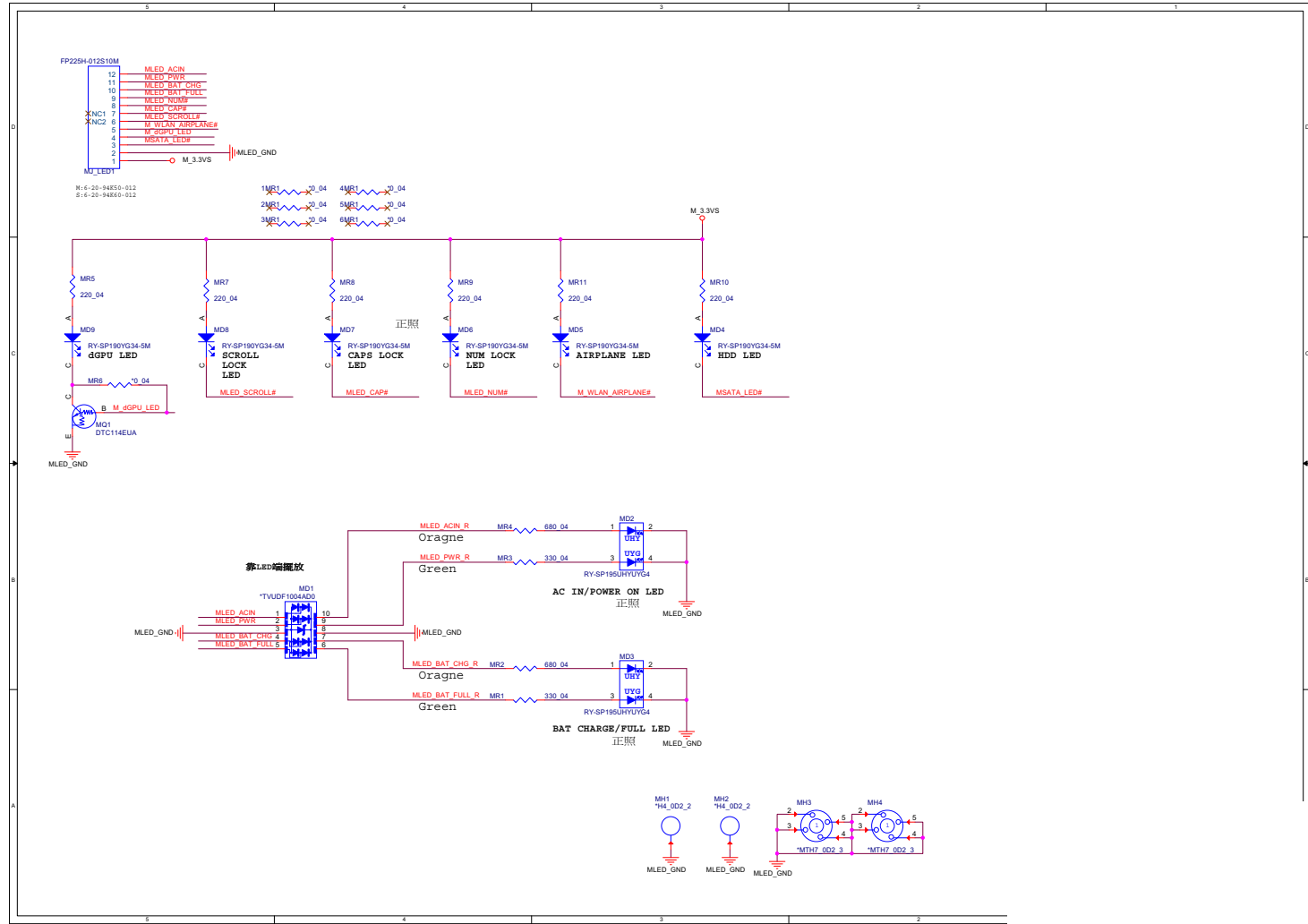

Sheet 65 of 77
LED Board

B.Schematic Diagrams

LID Board

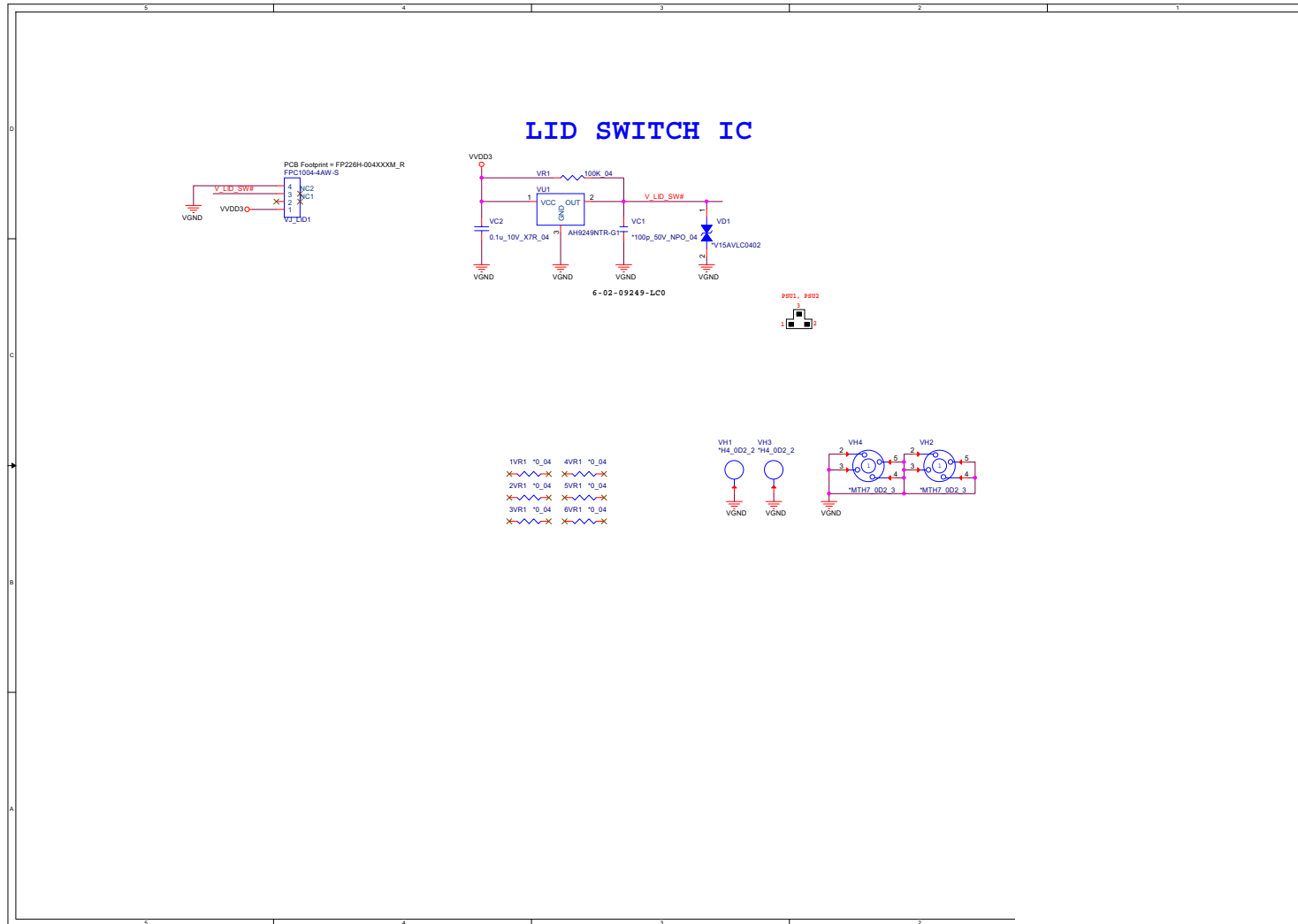

Sheet 66 of 77
LID Board

DC Board

Sheet 67 of 77
DC Board

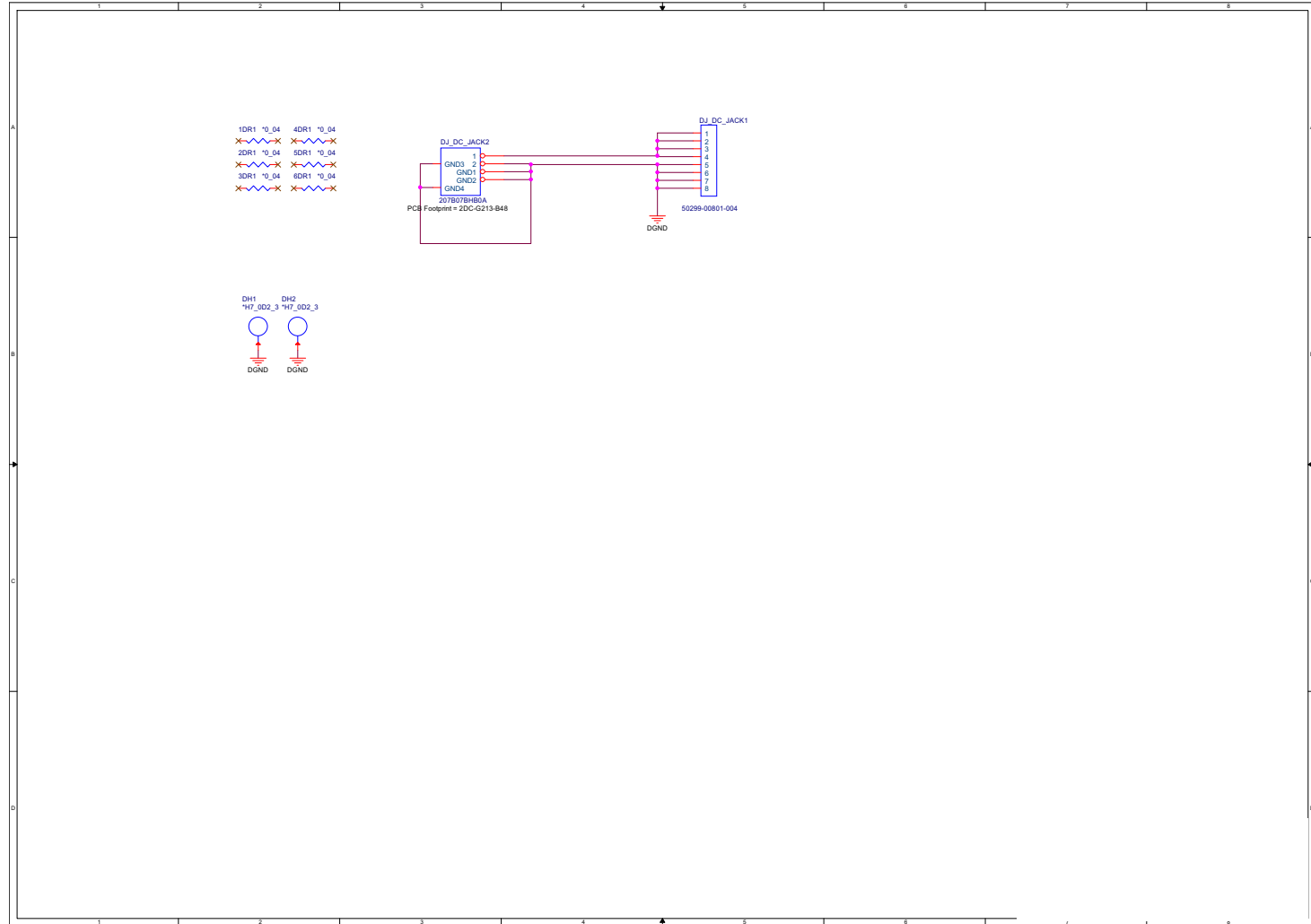

Power Board

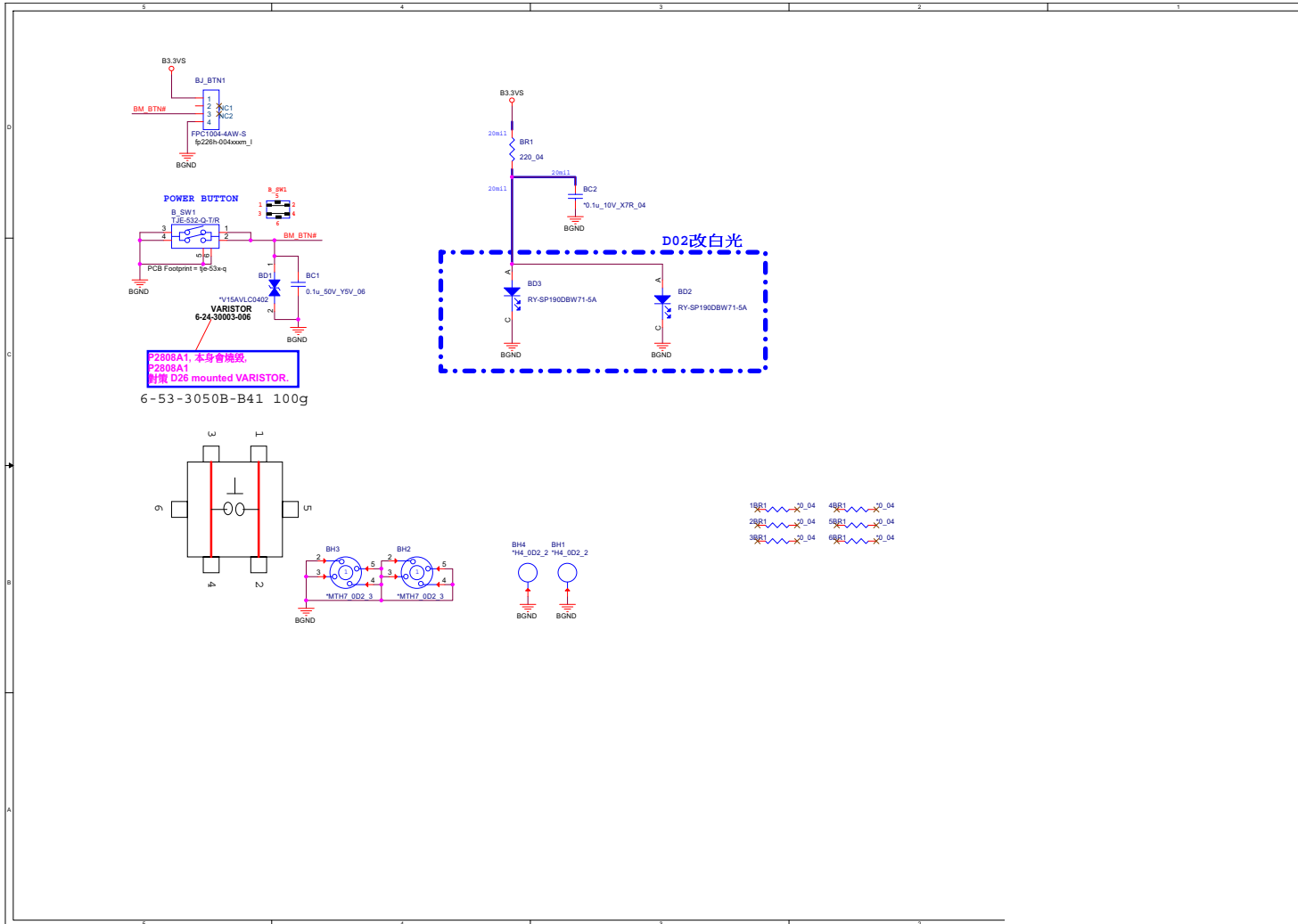

Sheet 68 of 77
Power Board

Click Board

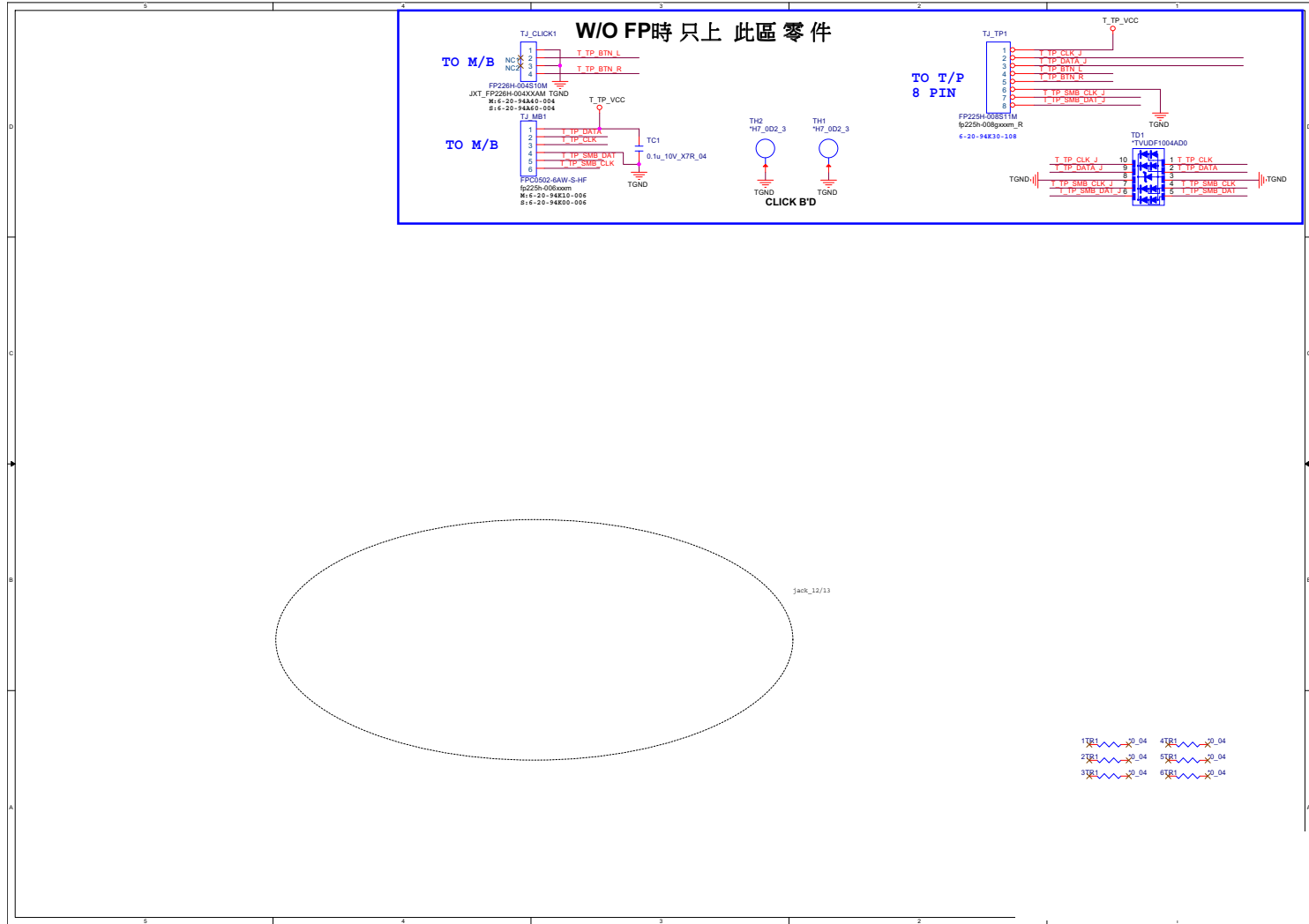

Sheet 69 of 77
Click Board

B.Schematic Diagrams

Audio Board

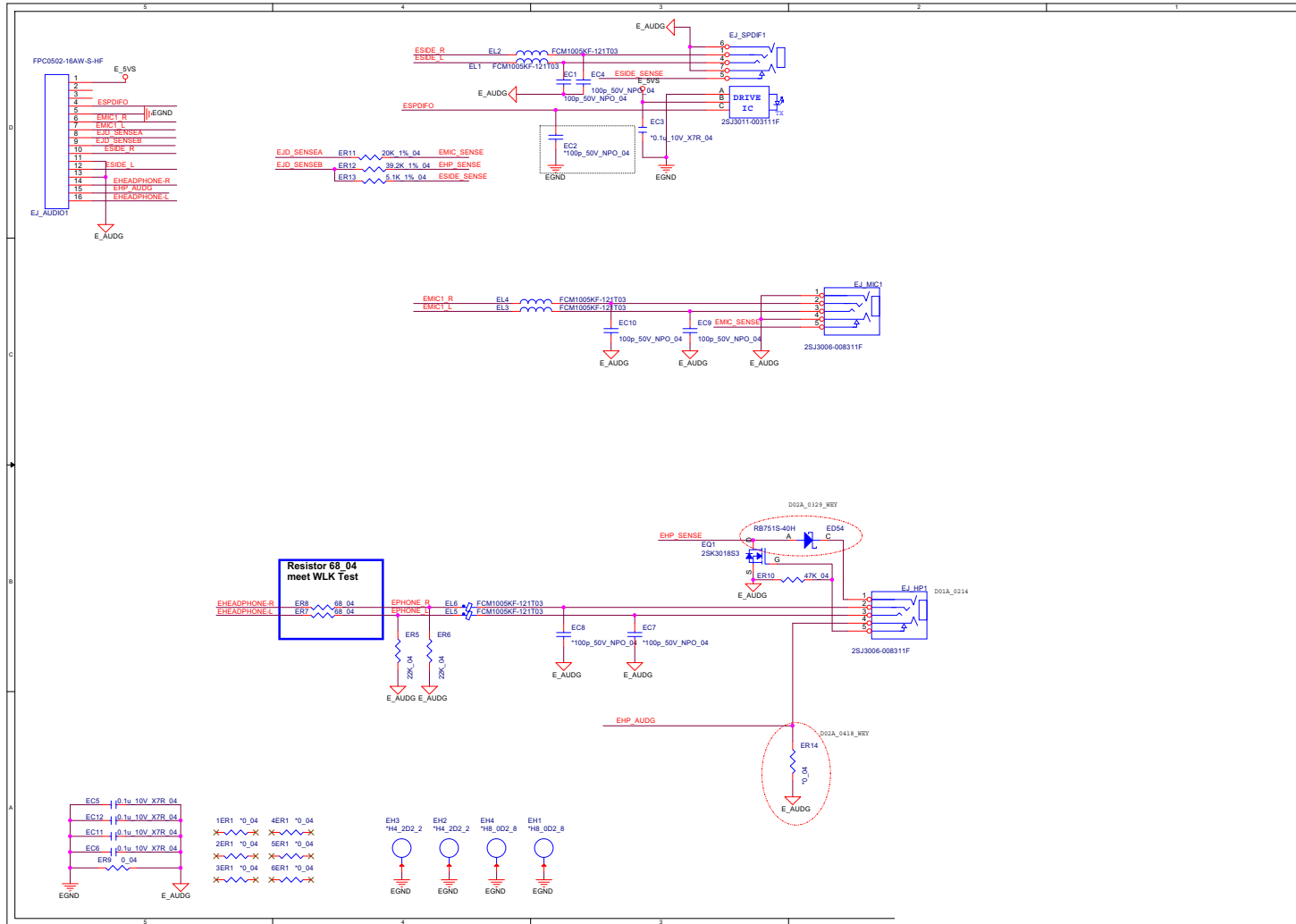

Sheet 70 of 77
Audio Board

B.Schematic Diagrams

USB Board

Sheet 71 of 77
USB Board

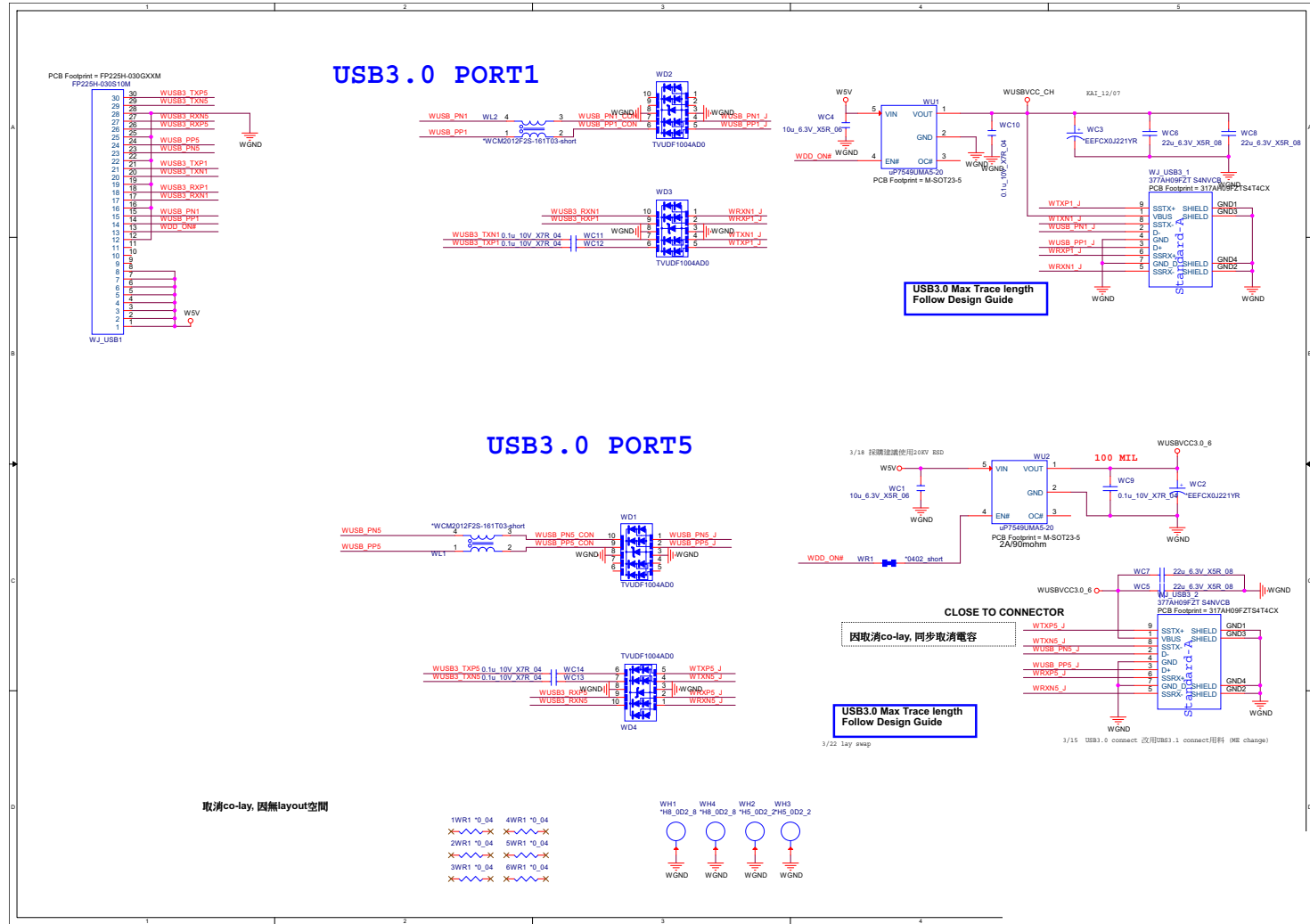

USB 3.0 Board

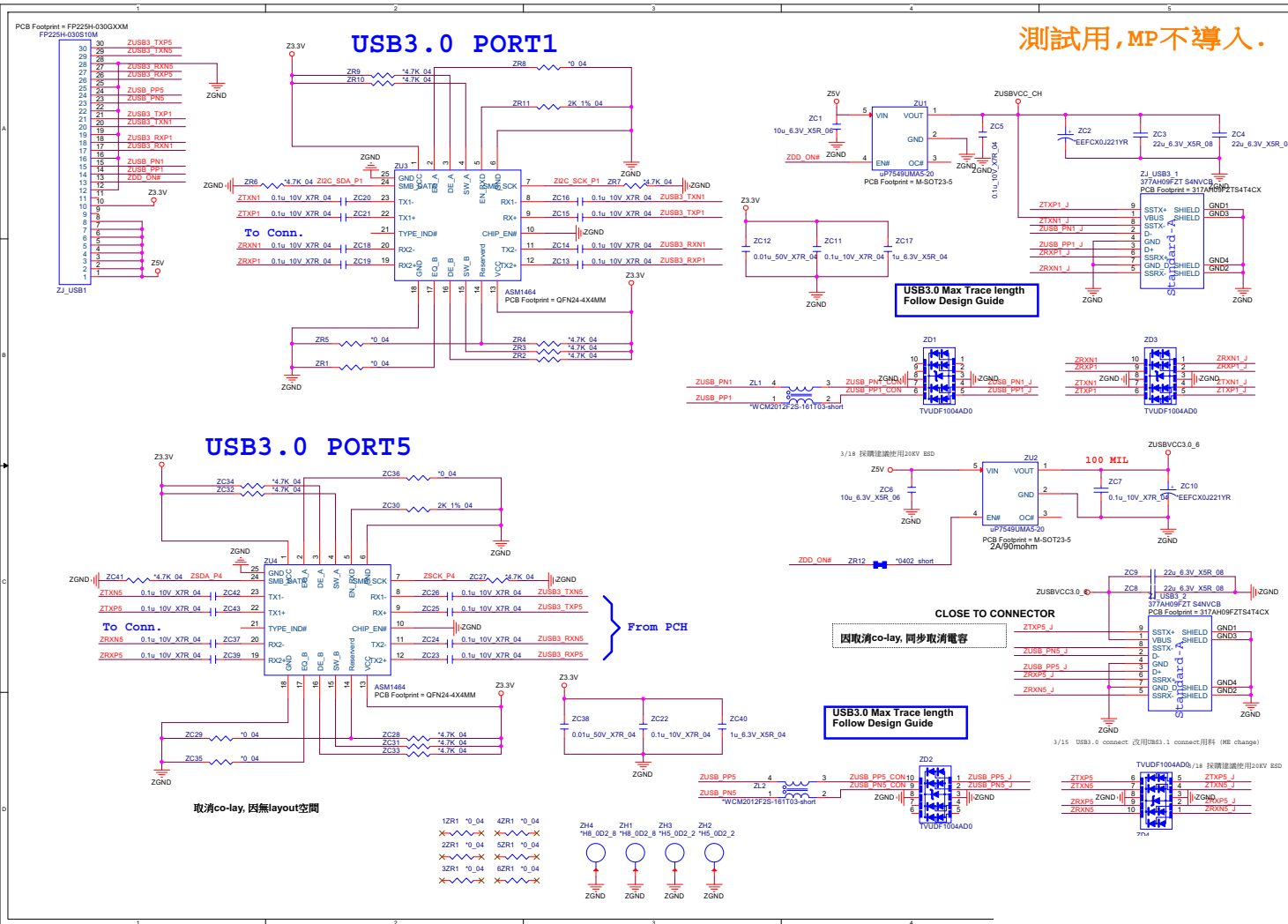

Sheet 72 of 77
USB 3.0 Board

B.Schematic Diagrams

PA7 Card Reader Board 1/4

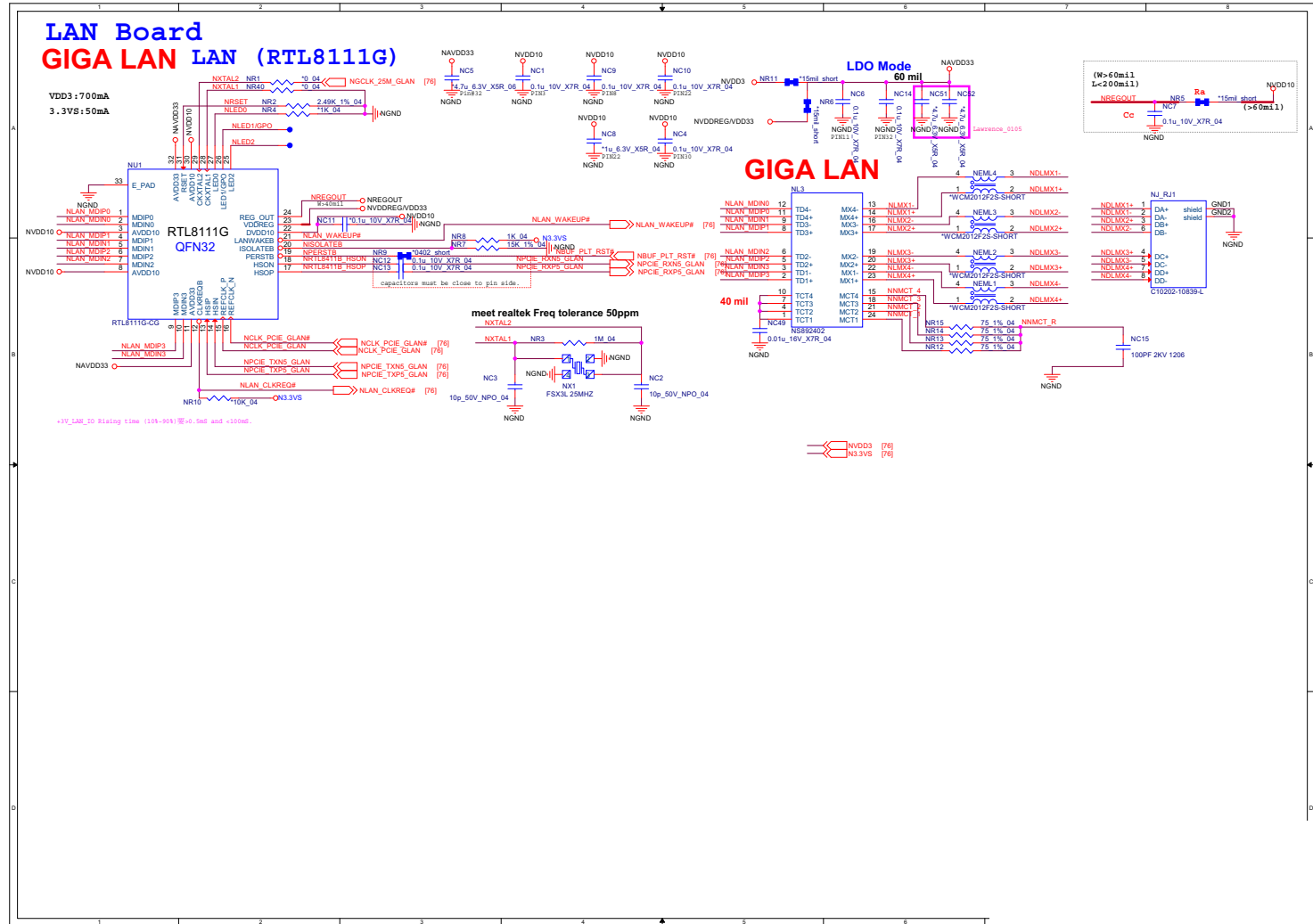

B.Schematic Diagrams

Sheet 73 of 77
PA7 Card Reader
Board 1/4

PA7 Card Reader Board 2/4

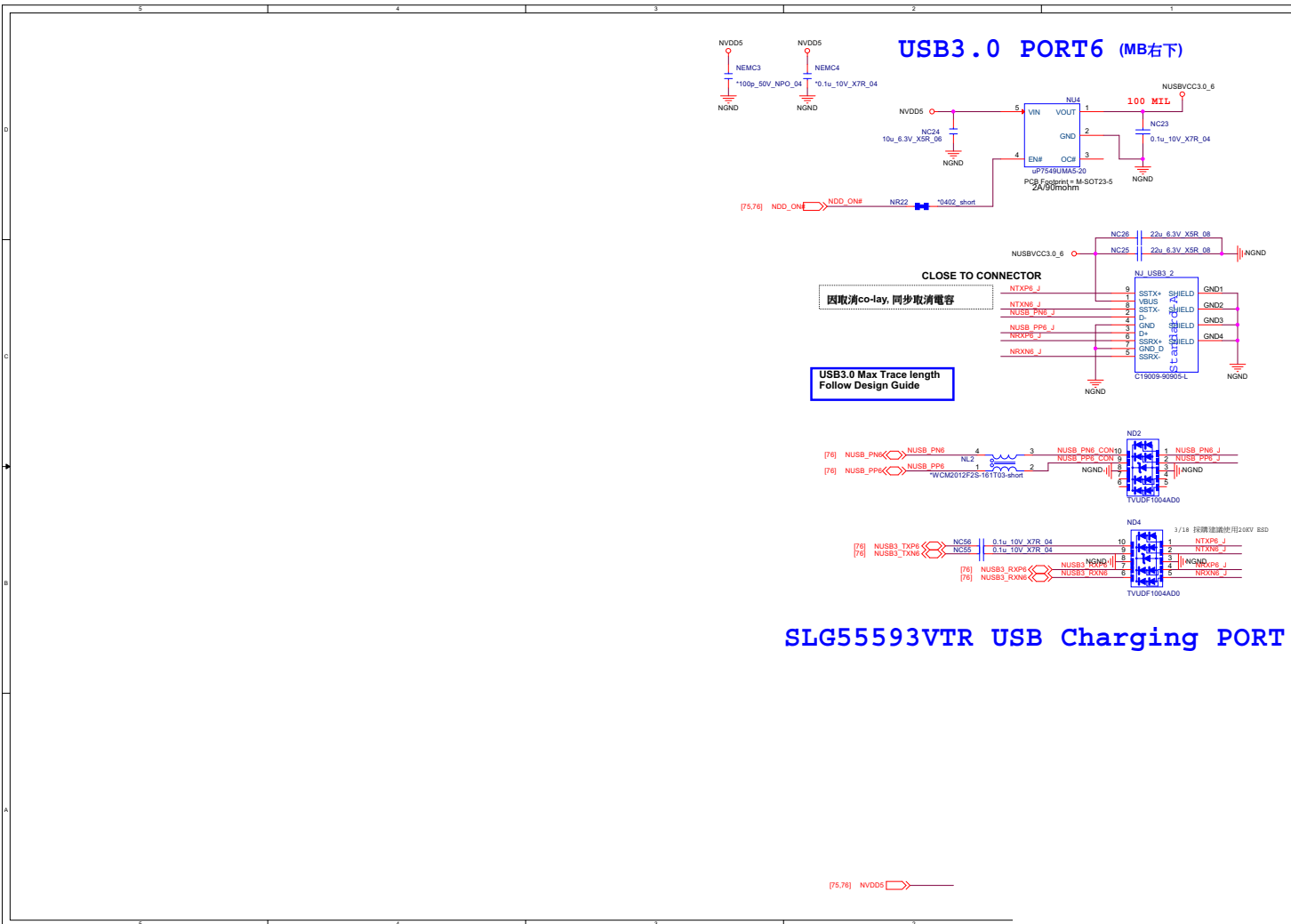

Sheet 74 of 77
PA7 Card Reader
Board 2/4

B.Schematic Diagrams

PA7 Card Reader Board 3/4

Sheet 75 of 77
PA7 Card Reader
Board 3/4

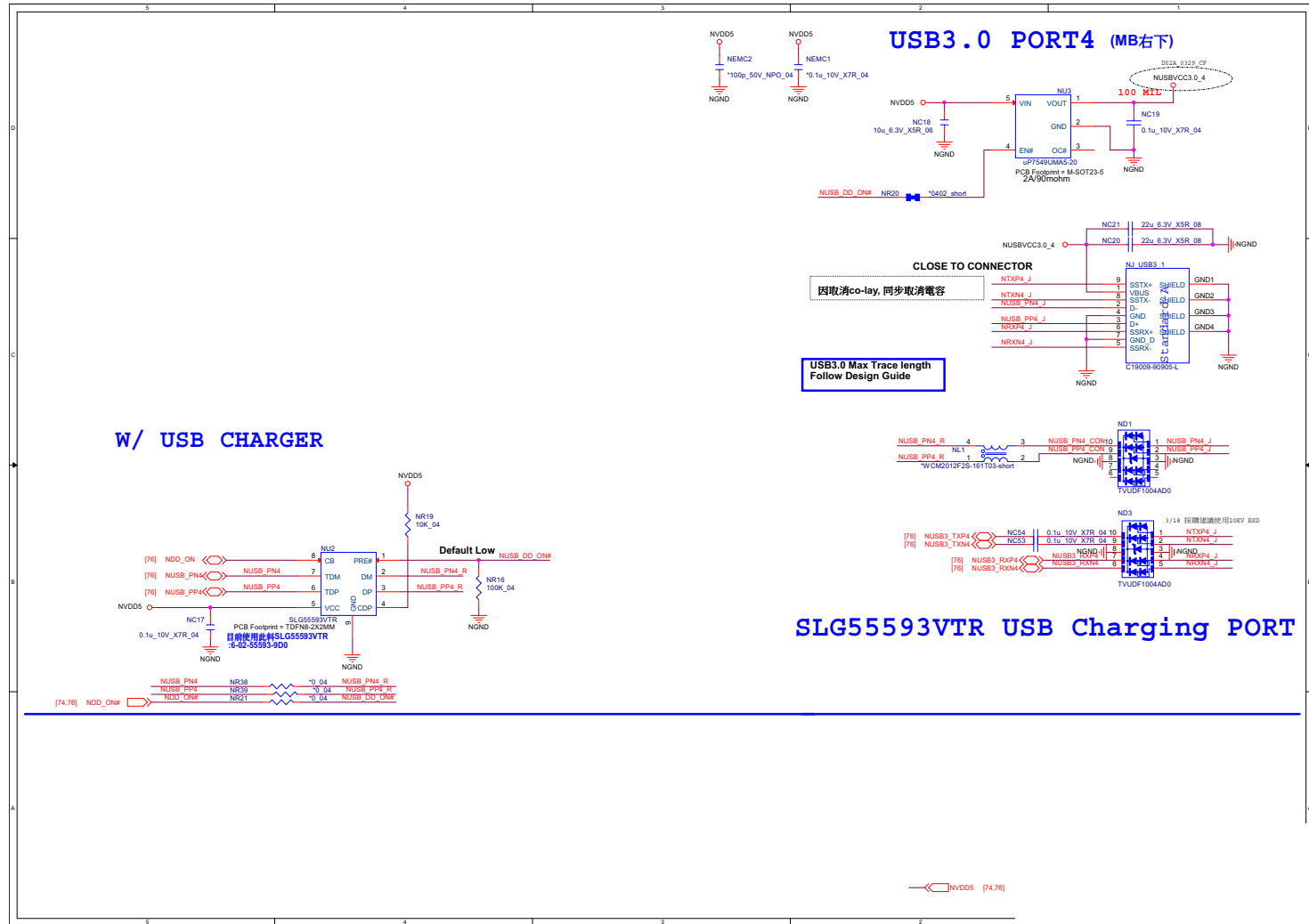

PA7 Card Reader Board 4/4

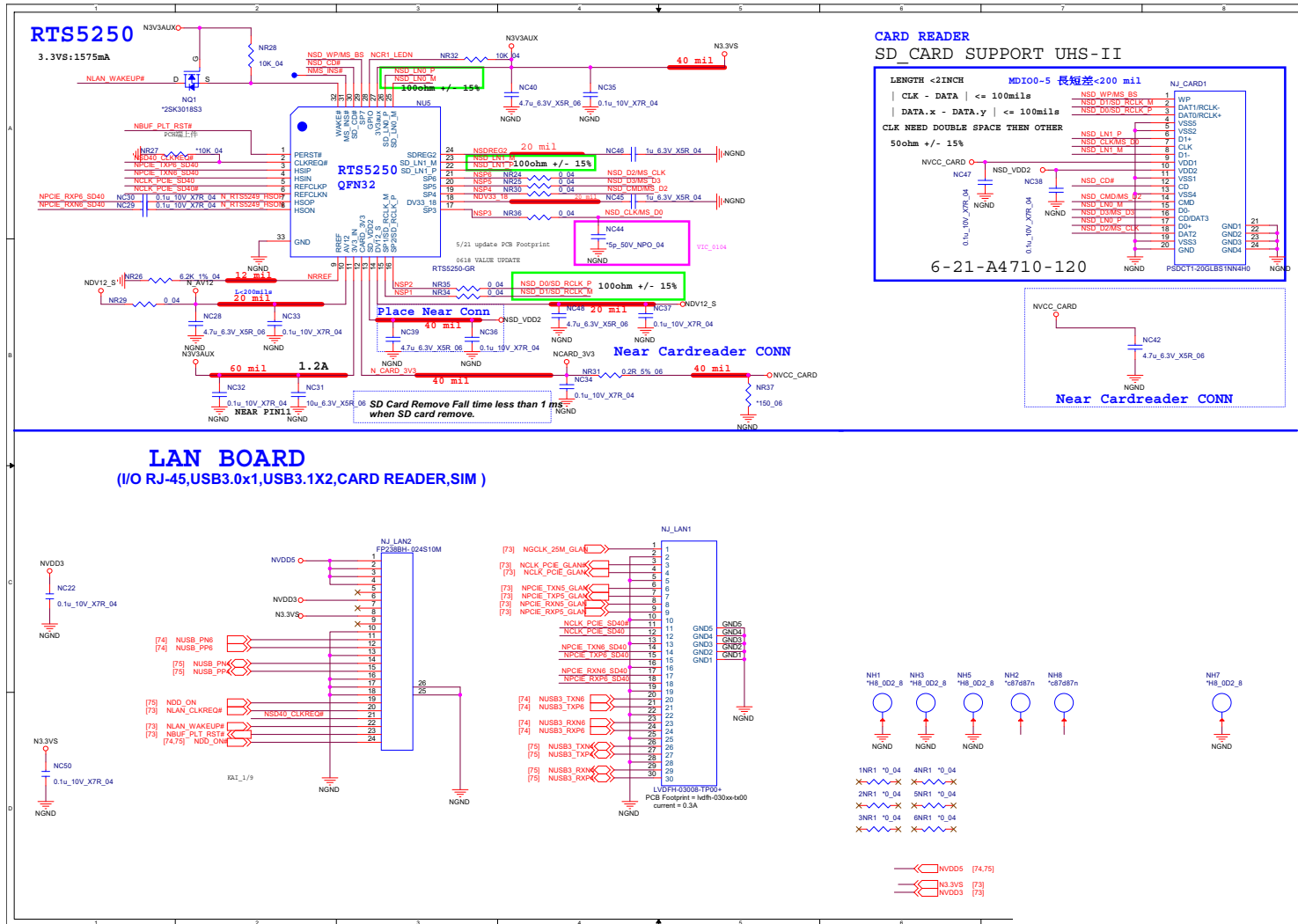

Sheet 76 of 77
PA7 Card Reader
Board 4/4

B.Schematic Diagrams

Power Sequence

Sheet 77 of 77
Power Sequence

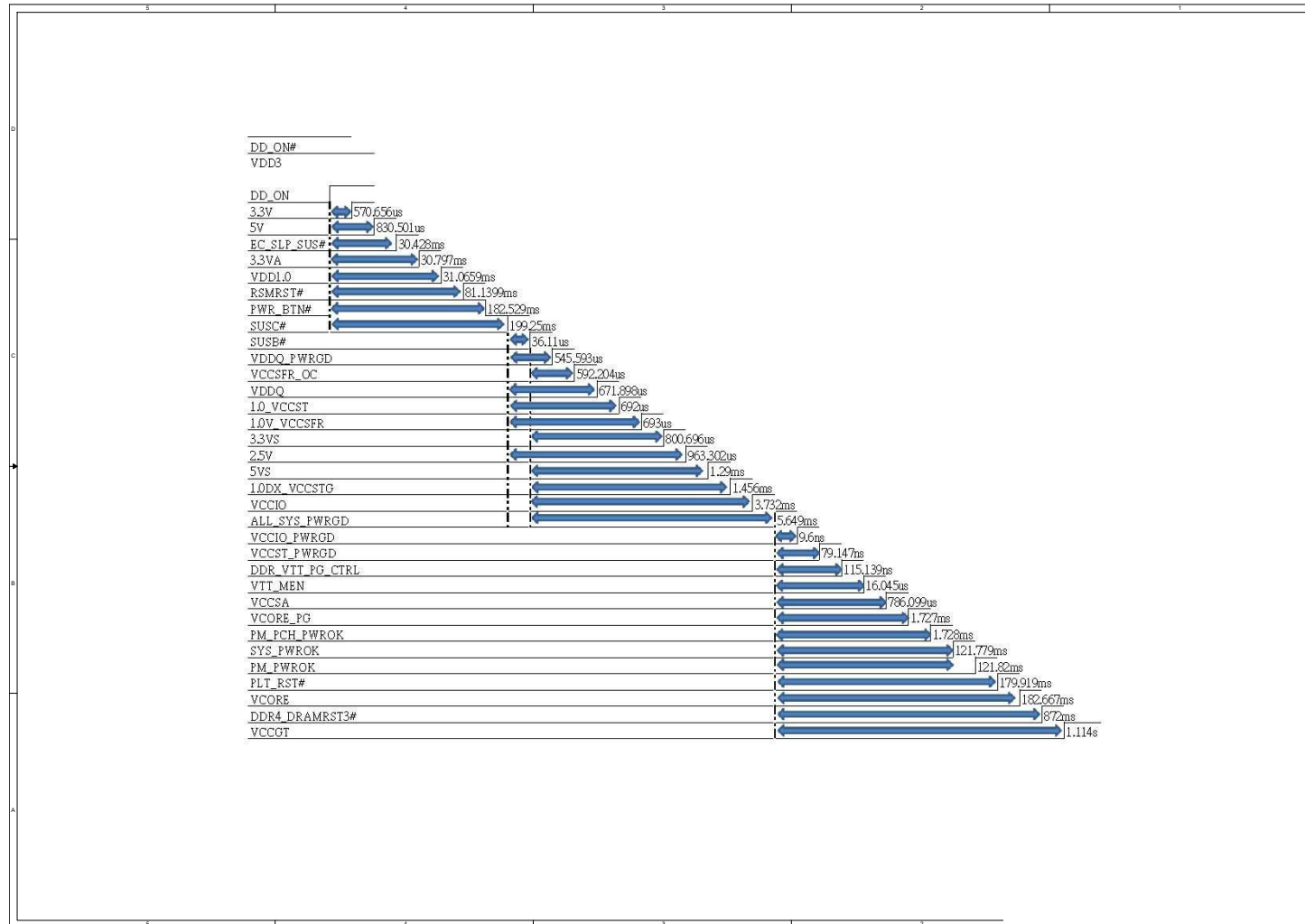

Appendix C: Updating the FLASH ROM BIOS

To update the FLASH ROM BIOS, you must:

- Download the BIOS update from the web site.
- Unzip the files onto a bootable CD/DVD/USB Flash Drive.
- Reboot your computer from an external CD/DVD/USB Flash Drive.
- Use the flash tools to update the flash BIOS using the commands indicated below.
- Restart the computer booting from the HDD and press **F2** at startup enter the BIOS.
- Load setup defaults from the BIOS and save the default settings and exit the BIOS to restart the computer.
- After rebooting the computer you may restart the computer again and make any required changes to the default BIOS settings.

Download the BIOS

1. Go to www.clevo.com.tw and point to **E-Services** and click **E-Channel**.
2. Use your user ID and password to access the appropriate download area (BIOS), and download the latest BIOS files (the BIOS file will be contained in a batch file that may be run directly once unzipped) for your computer model (see sidebar for important information on BIOS versions).

Unzip the downloaded files to a bootable CD/DVD or USB Flash drive

1. Insert a bootable CD/DVD/USB flash drive into the CD/DVD drive/USB port of the computer containing the downloaded files.
2. Use a tool such as Winzip or Winrar to unzip all the BIOS files and refresh tools to your bootable CD/DVD/USB flash drive (you may need to create a bootable CD/DVD with the files using a 3rd party software).

Set the computer to boot from the external drive

1. With the bootable CD/DVD/USB flash drive containing the BIOS files in your CD/DVD drive/USB port, restart the computer and press **F2** (in most cases) to enter the BIOS.
2. Use the arrow keys to highlight the **Boot** menu.
3. Use the “+” and “-” keys to move boot devices up and down the priority order.
4. Make sure that the CD/DVD drive/USB flash drive is set first in the boot priority of the BIOS.
5. Press **F4** to save any changes you have made and exit the BIOS to restart the computer.



BIOS Version

Make sure you download the latest correct version of the BIOS appropriate for the computer model you are working on.

You should only download BIOS versions that are V1.0X.XX or higher as appropriate for your computer model.

Note that BIOS versions are not backward compatible and therefore **you may not downgrade your BIOS to an older version** after upgrading to a later version (e.g if you upgrade a BIOS to ver 1.0X.05, you **MAY NOT** then go back and flash the BIOS to ver 1.0X.04).

BIOS Update

Use the flash tools to update the BIOS

1. Make sure you are not loading any memory management programs such as HIMEM by holding the **F8** key as you see the message “**EFI Shell**”. You will then be prompted to give “**Y**” or “**N**” responses to the programs being loaded by EFI Shell. Choose “**N**” for any memory management programs.
2. You should now see **DISK fsX:\>** (X is the designated drive number for the CD/DVD drive/USB flash drive).
3. **Type the following command:**

fsX:\> Flash.nsh

4. The utility will then proceed to flash the BIOS.
5. You should then be prompted to press any key to restart the system or turn the power off, and then on again but make sure you remove the CD/DVD/USB flash drive from the CD/DVD drive/USB port before the computer restarts.

Restart the computer (booting from the HDD)

1. With the CD/DVD/USB flash drive removed from the CD/DVD drive/USB port the computer should restart from the HDD.
2. Press **F2** as the computer restarts to enter the BIOS.
3. Use the arrow keys to highlight the **Exit** menu.
4. Select **Load Setup Defaults** (or press **F3**) and select “**Yes**” to confirm the selection.
5. Press **F4** to save any changes you have made and exit the BIOS to restart the computer.

Your computer is now running normally with the updated BIOS

You may now enter the BIOS and make any changes you require to the default settings.