

SERVICE MANUAL

notebook

N850HL



Notebook Computer

N850HL

Service Manual

Notice

The company reserves the right to revise this publication or to change its contents without notice. Information contained herein is for reference only and does not constitute a commitment on the part of the manufacturer or any subsequent vendor. They assume no responsibility or liability for any errors or inaccuracies that may appear in this publication nor are they in anyway responsible for any loss or damage resulting from the use (or misuse) of this publication.

This publication and any accompanying software may not, in whole or in part, be reproduced, translated, transmitted or reduced to any machine readable form without prior consent from the vendor, manufacturer or creators of this publication, except for copies kept by the user for backup purposes.

Brand and product names mentioned in this publication may or may not be copyrights and/or registered trademarks of their respective companies. They are mentioned for identification purposes only and are not intended as an endorsement of that product or its manufacturer.

Version 1.0
July 2017

Trademarks

Intel and Intel Core are trademarks of Intel Corporation.

Windows[®] is a registered trademark of Microsoft Corporation.

Other brand and product names are trademarks and /or registered trademarks of their respective companies.



About this Manual

This manual is intended for service personnel who have completed sufficient training to undertake the maintenance and inspection of personal computers.

It is organized to allow you to look up basic information for servicing and/or upgrading components of the *N850HL* series notebook PC.

The following information is included:

Chapter 1, Introduction, provides general information about the location of system elements and their specifications.

Chapter 2, Disassembly, provides step-by-step instructions for disassembling parts and subsystems and how to upgrade elements of the system.

Appendix A, Part Lists

Appendix B, Schematic Diagrams

Appendix C, Updating the FLASH ROM BIOS

IMPORTANT SAFETY INSTRUCTIONS

Follow basic safety precautions, including those listed below, to reduce the risk of fire, electric shock and injury to persons when using any electrical equipment:

1. Do not use this product near water, for example near a bath tub, wash bowl, kitchen sink or laundry tub, in a wet basement or near a swimming pool.
2. Avoid using a telephone (other than a cordless type) during an electrical storm. There may be a remote risk of electrical shock from lightning.
3. Do not use the telephone to report a gas leak in the vicinity of the leak.
4. Use only the power cord and batteries indicated in this manual. Do not dispose of batteries in a fire. They may explode. Check with local codes for possible special disposal instructions.
5. This product is intended to be supplied by a Listed Power Unit as follows:
 - AC Input of 100 - 240V, 50 - 60Hz, DC Output of 19V, 4.74A (**90** Watts) minimum AC/DC Adapter.

FCC Statement

This device complies with Part 15 of the FCC Rules. Operation is subject to the following two conditions:

This device may not cause harmful interference.

This device must accept any interference received, including interference that may cause undesired operation.

Instructions for Care and Operation

The notebook computer is quite rugged, but it can be damaged. To prevent this, follow these suggestions:

1. **Don't drop it, or expose it to shock.** If the computer falls, the case and the components could be damaged.



2. **Keep it dry, and don't overheat it.** Keep the computer and power supply away from any kind of heating element. This is an electrical appliance. If water or any other liquid gets into it, the computer could be badly damaged.

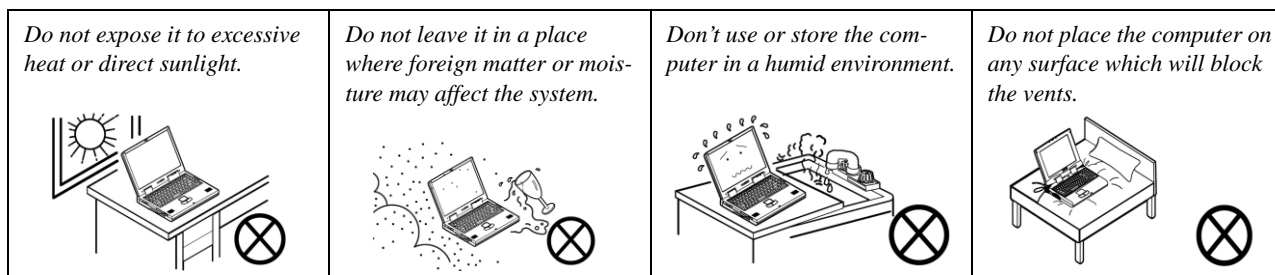

3. **Follow the proper working procedures for the computer.** Shut the computer down properly and don't forget to save your work. Remember to periodically save your data as data may be lost if the battery is depleted.

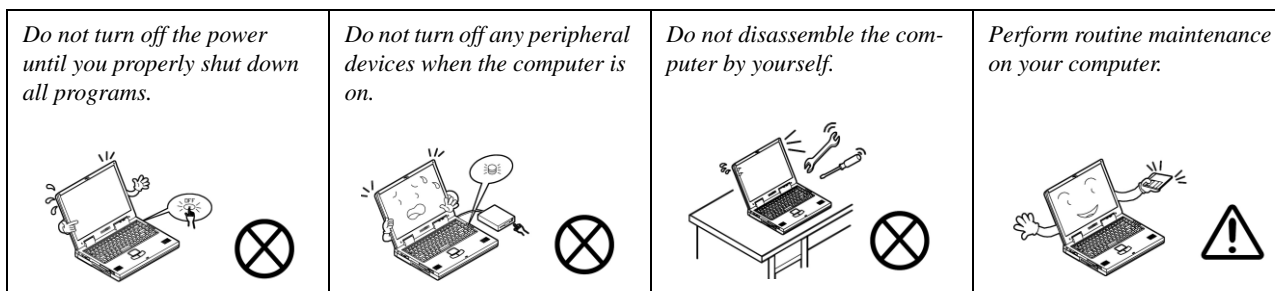

4. **Avoid interference.** Keep the computer away from high capacity transformers, electric motors, and other strong magnetic fields. These can hinder proper performance and damage your data.
5. **Take care when using peripheral devices.**

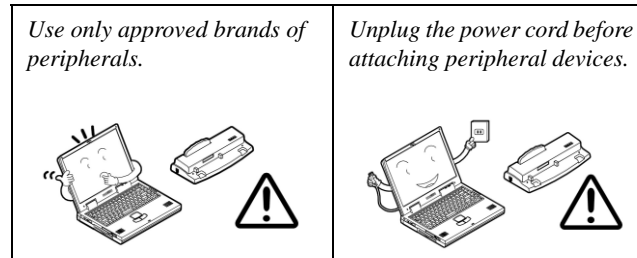

Power Safety

The computer has specific power requirements:

- Only use a power adapter approved for use with this computer.
- Your AC adapter may be designed for international travel but it still requires a steady, uninterrupted power supply. If you are unsure of your local power specifications, consult your service representative or local power company.
- The power adapter may have either a 2-prong or a 3-prong grounded plug. The third prong is an important safety feature; do not defeat its purpose. If you do not have access to a compatible outlet, have a qualified electrician install one.
- When you want to unplug the power cord, be sure to disconnect it by the plug head, not by its wire.
- Make sure the socket and any extension cord(s) you use can support the total current load of all the connected devices.
- Before cleaning the computer, make sure it is disconnected from any external power supplies.

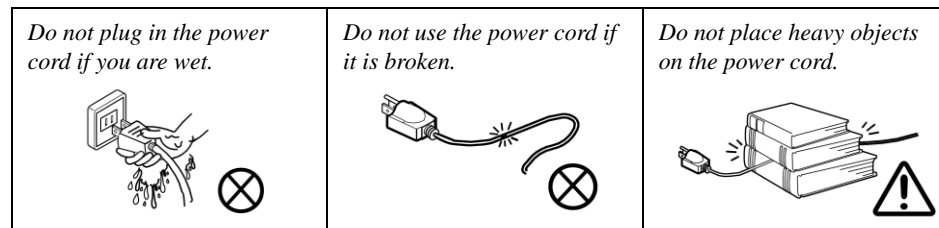

Power Safety Warning

Before you undertake any upgrade procedures, make sure that you have turned off the power, and disconnected all peripherals and cables (including telephone lines and power cord). It is advisable to also remove your battery in order to prevent accidentally turning the machine on.

Battery Precautions

- Only use batteries designed for this computer. The wrong battery type may explode, leak or damage the computer.
- Do not continue to use a battery that has been dropped, or that appears damaged (e.g. bent or twisted) in any way. Even if the computer continues to work with a damaged battery in place, it may cause circuit damage, which may possibly result in fire.
- Recharge the batteries using the notebook's system. Incorrect recharging may make the battery explode.
- Do not try to repair a battery pack. Refer any battery pack repair or replacement to your service representative or qualified service personnel.
- Keep children away from, and promptly dispose of a damaged battery. Always dispose of batteries carefully. Batteries may explode or leak if exposed to fire, or improperly handled or discarded.
- Keep the battery away from metal appliances.
- Affix tape to the battery contacts before disposing of the battery.
- Do not touch the battery contacts with your hands or metal objects.

Battery Guidelines

The following can also apply to any backup batteries you may have.

- If you do not use the battery for an extended period, then remove the battery from the computer for storage.
- Before removing the battery for storage charge it to 60% - 70%.
- Check stored batteries at least every 3 months and charge them to 60% - 70%.



Battery Disposal

The product that you have purchased contains a rechargeable battery. The battery is recyclable. At the end of its useful life, under various state and local laws, it may be illegal to dispose of this battery into the municipal waste stream. Check with your local solid waste officials for details in your area for recycling options or proper disposal.

Caution

Danger of explosion if battery is incorrectly replaced. Replace only with the same or equivalent type recommended by the manufacturer. Discard used battery according to the manufacturer's instructions.

Battery Level

Click the battery icon  in the taskbar to see the current battery level and charge status. A battery that drops below a level of 10% will not allow the computer to boot up. Make sure that any battery that drops below 10% is recharged within one week.

Related Documents

You may also need to consult the following manual for additional information:

User's Manual on CD/DVD

This describes the notebook PC's features and the procedures for operating the computer and its ROM-based setup program. It also describes the installation and operation of the utility programs provided with the notebook PC.

System Startup

1. Remove all packing materials.
2. Place the computer on a stable surface.
3. Insert the battery and make sure it is locked in position.
4. Securely attach any peripherals you want to use with the computer (e.g. keyboard and mouse) to their ports.
5. **When first setting up the computer use the following procedure** (as to safeguard the computer during shipping, the battery will be locked to not power the system until first connected to the AC/DC adapter and initially set up as below):
 - Attach the AC/DC adapter cord to the DC-In jack on the left of the computer, then plug the AC power cord into an outlet, and connect the AC power cord to the AC/DC adapter and **leave it there for 6 seconds or longer**.
 - Remove the adapter cord from the computer's DC-In jack, and then plug it back in again; the battery will now be unlocked.
6. Use one hand to raise the lid/LCD to a comfortable viewing angle (do not exceed 135 degrees); use the other hand (as illustrated in Figure 1) to support the base of the computer (**Note: Never lift the computer by the lid/LCD**).
7. Press the power button to turn the computer "on".

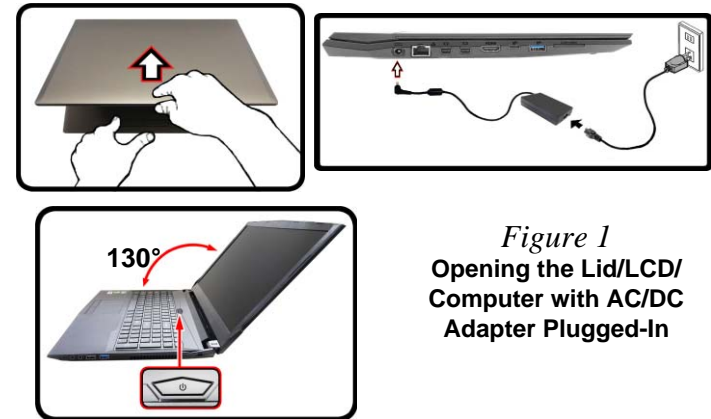



Figure 1
**Opening the Lid/LCD/
Computer with AC/DC
Adapter Plugged-In**

Powering the Computer On

After every disassembly, make sure that the bottom case's screws are all inserted and tightened before turning the computer on.

Shut Down

Note that you should always shut your computer down by choosing the **Shut down** command in **Windows** (see below). This will help prevent hard disk or system problems.

Click the icon  in the **Start Screen** and choose **Shut down** from the menu.

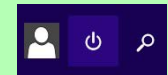

Or

Right-click the **Start button**  at the bottom of the **Start Screen** or the **Desktop** and choose **Shut down or sign out > Shut down** from the context menu.

Contents

Introduction	1-1	Main Board	A-5
Overview	1-1	HDD	A-6
Specifications	1-2	LCD	A-7
External Locator - Top View with LCD Panel Open	1-4	Schematic Diagrams.....	B-1
External Locator - Front & Right Side Views	1-5	System Block Diagram	B-2
External Locator - Left Side & Rear View	1-6	Processor 1/6	B-3
External Locator - Bottom View	1-7	Processor 2/6	B-4
Mainboard Overview - Top (Key Parts)	1-8	Processor 3/6	B-5
Mainboard Overview - Bottom (Key Parts)	1-9	Processor 4/6	B-6
Mainboard Overview - Top (Connectors)	1-10	Processor 5/6	B-7
Mainboard Overview - Bottom (Connectors)	1-11	Processor 6/6	B-8
Disassembly	2-1	DDR3 CHA SO-DIMM	B-9
Overview	2-1	DDR3 CHB SO-DIMM	B-10
Maintenance Tools	2-2	PS8625	B-11
Connections	2-2	Panel, Inverter	B-12
Maintenance Precautions	2-3	Mini DP Port	B-13
Disassembly Steps	2-4	HDMI PS8201	B-14
Removing the Keyboard	2-5	VGA Frame Buffer Interface	B-15
Removing the Battery	2-6	VGA Frame Buffer Interface	B-16
Removing the Hard Disk Drive	2-8	VGA Frame Buffer A	B-17
Removing the System Memory (RAM)	2-10	VGA Frame Buffer A	B-18
Removing and Installing the M.2 SSD Module	2-11	VGA Frame Buffer B	B-19
Removing the Wireless LAN Module	2-13	VGA Frame Buffer B	B-20
Wireless LAN, Combo, 3G & LTE Module Cables	2-14	VGA I/O	B-21
Removing the 3G Module	2-15	VGA NVVDD Decoupling	B-22
Part Lists	A-1	PCH 1/8	B-23
Part List Illustration Location	A-2	PCH 2/8	B-24
Top	A-3	PCH 3/8	B-25
Bottom	A-4	PCH 4/8	B-26
		PCH 5/8	B-27

Preface

PCH 6/8	B-28
PCH 7/8	B-29
PCH 8/8	B-30
USB 3.0	B-31
M.2 SATA & SSD	B-32
M.2 WLAN, SSD	B-33
KBC IT8587E	B-34
Audio Codec, ALC269VC2	B-35
LAN RTL8411B	B-36
Fan, KB, LED TPM, CCD	B-37
Connector	B-38
5V, 5VS, 3.3V, 3.3VS, 3.3VA	B-39
VDD3, VDD5	B-40
DDR 1.35V, 0.65VS	B-41
VDD1.0, VCCIO	B-42
VCCSTG, VCCSFR_OC	B-43
GPU Power 1/2	B-44
GPU Power 2/2	B-45
AC_In, Charger	B-46
VCore, VCCSA	B-47
VCore Output Stage	B-48
VCCGT	B-49
VCCGT Output Stage	B-50
Click Board	B-51
LED Board	B-52
Power Board	B-53
Audio Board 1/2	B-54
Audio Board 2/2	B-55
Power Sequence	B-56
Updating the FLASH ROM BIOS.....	C-1
Download the BIOS	C-1

Unzip the downloaded files to a bootable CD/DVD or USB Flash drive	C-1
Set the computer to boot from the external drive	C-1
Use the flash tools to update the BIOS	C-2
Restart the computer (booting from the HDD)	C-2

Chapter 1: Introduction

Overview

This manual covers the information you need to service or upgrade the **N850HL** series notebook computer. Information about operating the computer (e.g. getting started, and the *Setup* utility) is in the *User's Manual*. Information about drivers (e.g. VGA & audio) is also found in the *User's Manual*. The manual is shipped with the computer.

Operating systems (e.g. *Windows 10*, etc.) have their own manuals as do application softwares (e.g. word processing and database programs). If you have questions about those programs, you should consult those manuals.

The **N850HL** series notebook is designed to be upgradeable. See [Disassembly on page 2 - 1](#) for a detailed description of the upgrade procedures for each specific component. Please take note of the warning and safety information indicated by the “” symbol.

The balance of this chapter reviews the computer's technical specifications and features.

Introduction

Specifications



Latest Specification Information

The specifications listed here are correct at the time of sending them to the press. Certain items (particularly processor types/speeds) may be changed, delayed or updated due to the manufacturer's release schedule. Check with your service center for more details.



CPU

The CPU is not a user serviceable part. Accessing the CPU in any way may violate your warranty.

Processor Options

Intel® Core™ i7 Processor

i7-7700HQ (2.80GHz)

6MB Smart Cache, 14nm, DDR4-2400MHz, TDP 45W

Intel® Core™ i5 Processor

i5-7300HQ (2.50GHz)

6MB Smart Cache, 14nm, DDR4-2400MHz, TDP 45W

Intel® Core™ i3 Processor

i3-7100H (3.00GHz)

3MB Smart Cache, 14nm, DDR4-2400MHz, TDP 35W

Core Logic

Intel® HM175 Chipset

BIOS

64Mb SPI Flash ROM

AMI BIOS

Memory

Two 260 Pin SO-DIMM Sockets Supporting **DDR4 2400MHz** Memory

Memory Expandable up to 32GB

(The real memory operating frequency depends on the FSB of the processor.)

LCD Options

15.6" (39.62cm), 16:9, HD (1366x768)/FHD (1920x1080)

Video Adapter

Intel® Integrated GPU and NVIDIA® Discrete GPU

Supports Microsoft Hybrid Graphics

Intel Integrated GPU

Intel HD Graphics 630

Dynamic Frequency

Intel Dynamic Video Memory Technology

Microsoft DirectX®12 Compatible

NVIDIA® Discrete GPU

NVIDIA® GeForce MX150

2GB GDDR5 Video RAM on board

Microsoft DirectX® 12 Compatible

Storage

One Changeable 2.5" 7.0mm (h) SATA3 HDD/SSD

(**Factory Option**) One M.2 **SATA/PCIe Gen3 x4** Solid State Drive (SSD)

Audio

High Definition Audio Compliant Interface

2 * Built-In Speakers

Built-In Array Microphone

Or

(**Factory Option**) Built-In Microphone

Sound Blaster™ Cinema 3

Security

Security (Kensington® Type) Lock Slot

BIOS Password

Intel PTT for systems without hardware TPM

(**Factory Option**) TPM v 2.0

Keyboard

Full-size “WinKey” keyboard (with numeric keypad)

Or

(Factory Option) Full-size “WinKey” **Illuminated White-LED** Keyboard (with numeric keypad)

Pointing Device

Built-in Touchpad

Interface

One USB 2.0 Port

One USB 3.0 (USB 3.1 Gen 1) Type-A Port

One USB 3.0 (USB 3.1 Gen 1) Type-A Port and one USB 3.0 (USB 3.1 Gen 1) Type-C Port*

Or

(Factory Option) One USB 3.1 Gen 2 Type-A Port and one USB 3.1 Gen 2 Type-C Port*

One HDMI-Out Port

One External Monitor Port

One Headphone-Out Jack

One Microphone-In Jack

One RJ-45 LAN Jack

One DC-in Jack

**USB 3.1 Gen 2**

Note that when a single USB device is plugged in to a USB 3.1 Gen 2 port the data transfer speed will be 10Gbps, however when two devices are plugged in to both USB 3.1 Gen 2 ports, this bandwidth will be shared between the ports.

Card Reader

Embedded Multi-In-1 Card Reader

MMC (MultiMedia Card) / RS MMC

SD (Secure Digital) / Mini SD / SDHC/ SDXC

M.2 Slots

Slot 1 for **WLAN and Bluetooth** Combo Module

Slot 2 for **SATA/PCIe Gen3 x4 SSD**

(Factory Option) Slot 3 for **3G/4G** Module

Communication

Built-In Gigabit Ethernet LAN

1.0M HD PC Camera Module

(Factory Option) 2.0M FHD PC Camera Module

(Factory Option) M.2 **3G** or **4G** Module

WLAN/ Bluetooth M.2 Modules:

(Factory Option) Intel® Dual Band Wireless-AC 8265 Wireless LAN (**802.11ac**) + Bluetooth **4.1**

(Factory Option) Intel® Dual band Wireless-AC 3168 Wireless LAN (**802.11ac**) + Bluetooth **4.0**

Environmental Spec**Temperature**

Operating: 5°C - 35°C

Non-Operating: -20°C - 60°C

Relative Humidity

Operating: 20% - 80%

Non-Operating: 10% - 90%

Power

Full Range AC/DC Adapter

AC Input: 100 - 240V, 50 - 60Hz

DC Output: 19V, 4.74A (**90W**)

(Factory Option) Removable 6 Cell Smart Lithium-Ion Battery Pack, 62WH

(Factory Option) Removable 6 Cell Smart Lithium-Ion Battery Pack, 47WH

Dimensions & Weight

378mm (w) * 267mm (d) * 24.9mm (h)

2.3kg (Barebone with 47WH Battery)

Introduction

Figure 1
Top View

1. PC Camera
2. *PC Camera LED
**When the PC camera is in use, the LED will be illuminated.*
3. Built-In Array Microphone
4. LCD
5. Power Button
6. Keyboard
7. Touchpad & Buttons

External Locator - Top View with LCD Panel Open



External Locator - Front & Right Side Views

FRONT VIEW



Figure 2
Front View
1. LED Indicator

RIGHT SIDE VIEW



Figure 3
Right Side View
1. Headphone-Out Jack
2. Microphone-In Jack
3. USB 2.0 Port
4. USB 3.0 (USB 3.1 Gen 1) Type A Port
5. Vent
6. Security Lock Slot

Introduction

External Locator - Left Side & Rear View

Figure 4

Left Side View

1. DC-In Jack
2. RJ-45 LAN Jack
3. External Monitor Port
4. HDMI-Out Port
5. USB 3.0 (USB 3.1 Gen 1) Type C Port Or
(Factory Option)
USB 3.1 Gen 2 Type C Port
6. USB 3.0 (USB 3.1 Gen 1) Type A Port Or
(Factory Option)
USB 3.1 Gen 2 Type A Port
7. Multi-in-1 Card Reader

LEFT SIDE VIEW



REAR VIEW



Figure 5

Rear View

1. Vent

External Locator - Bottom View



Figure 6
Bottom View

- 1. Battery
- 2. Vent
- 3. Speakers

Overheating

To prevent your computer from overheating, make sure nothing blocks any vent while the computer is in use.

Introduction

Figure 7
Mainboard Top
Key Parts

1. KBC-ITE IT8587

Mainboard Overview - Top (Key Parts)

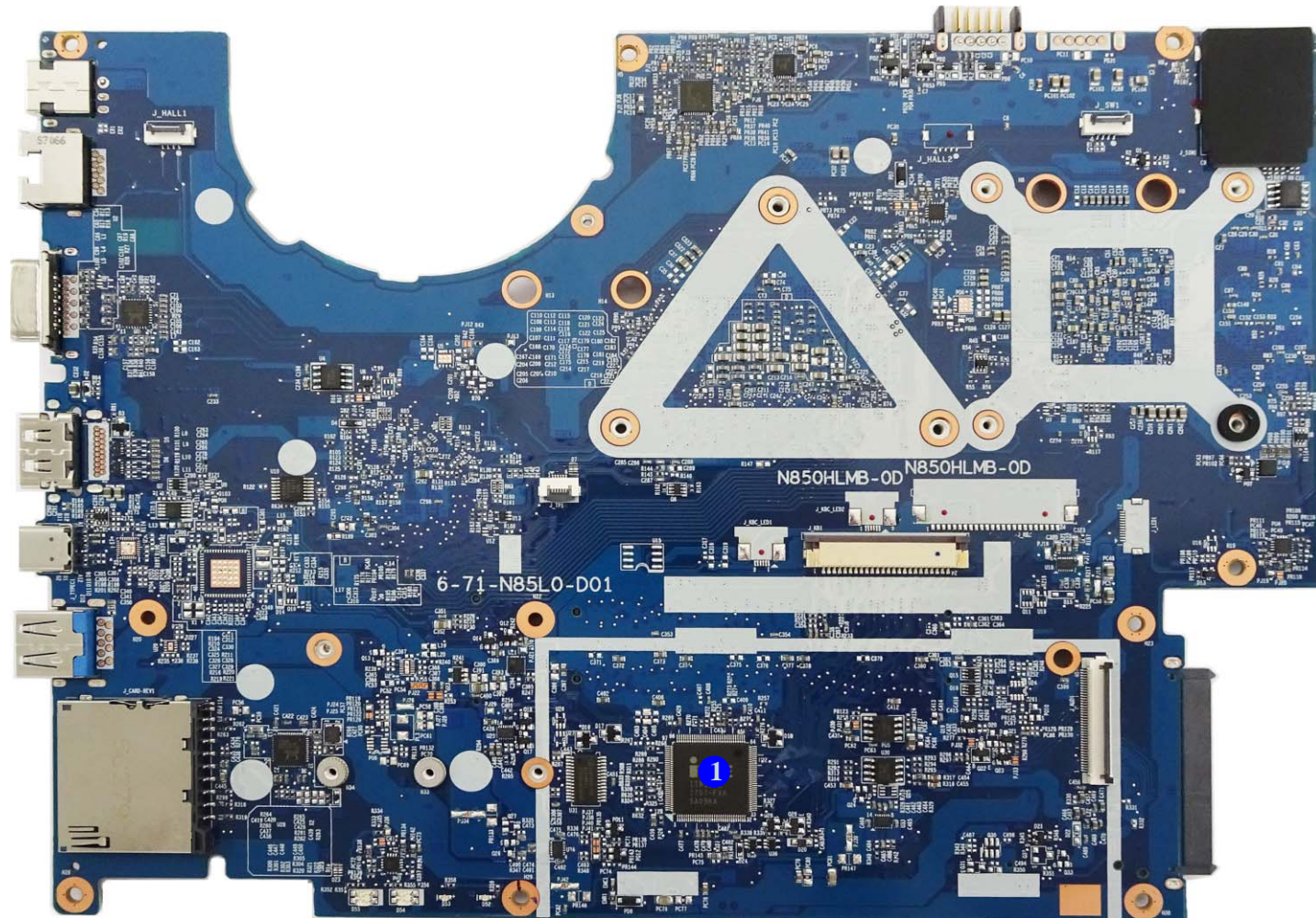

Mainboard Overview - Bottom (Key Parts)

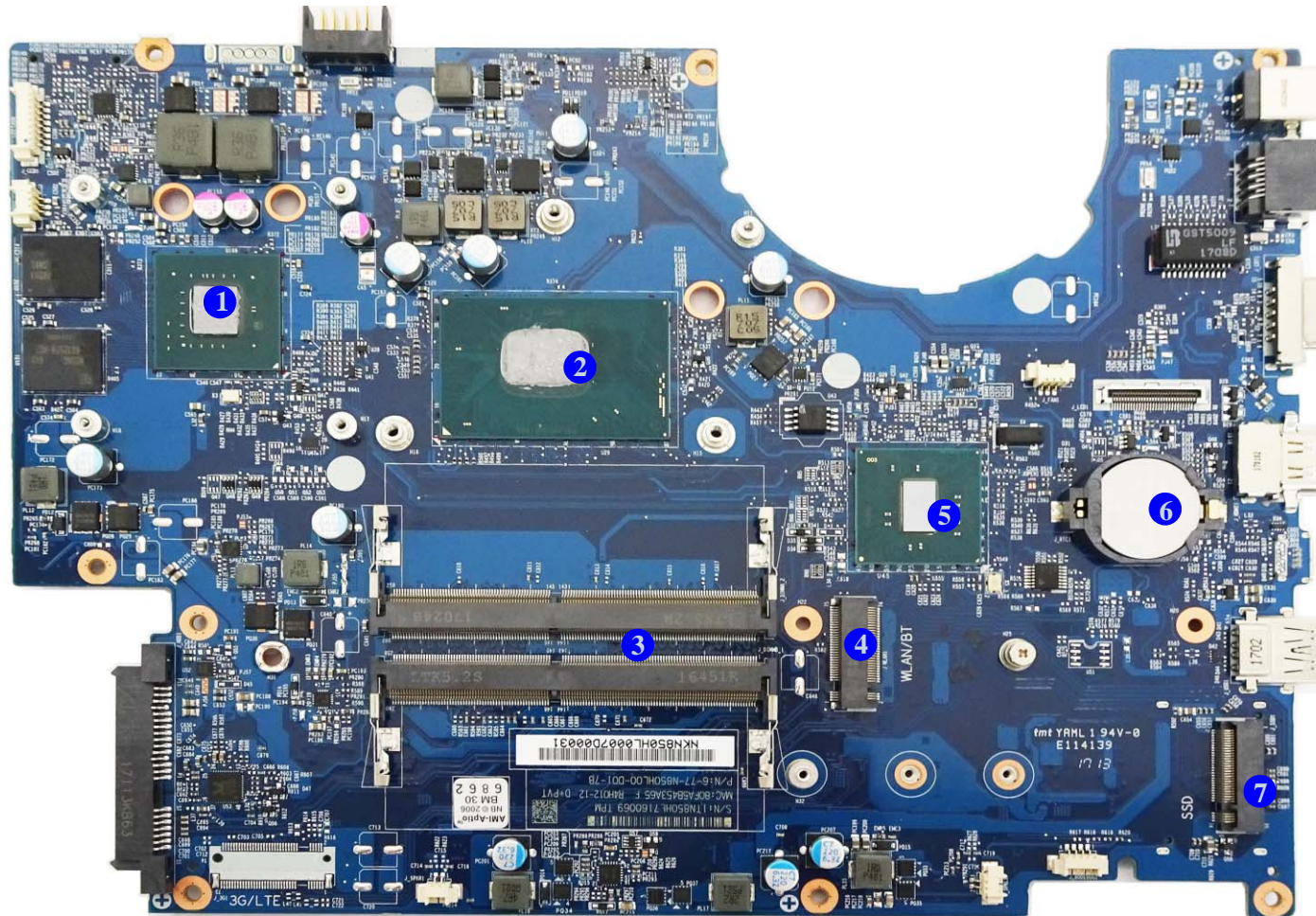

Figure 8
Mainboard Bottom
Key Parts

1. GPU
2. CPU
3. Memory Slots
DDR4 SO-DIMM
4. Mini-Card
Connector (WLAN
Module)
5. PCH
6. CMOS Battery
7. M.2-Card
Connector (SSD
Module)

Introduction

Figure 9
**Mainboard Top
Connectors**

1. DC-In Jack
2. RJ-45 LAN Jack
3. External Display Port
4. HDMI-Out Port
5. USB Port 3.0/3.1 (Type C) Connector
6. USB Port 3.0/3.1 (Type A) Connector
7. Multi-in-1 Card Reader
8. KB LED Connector
9. Keyboard Cable Connector

Mainboard Overview - Top (Connectors)

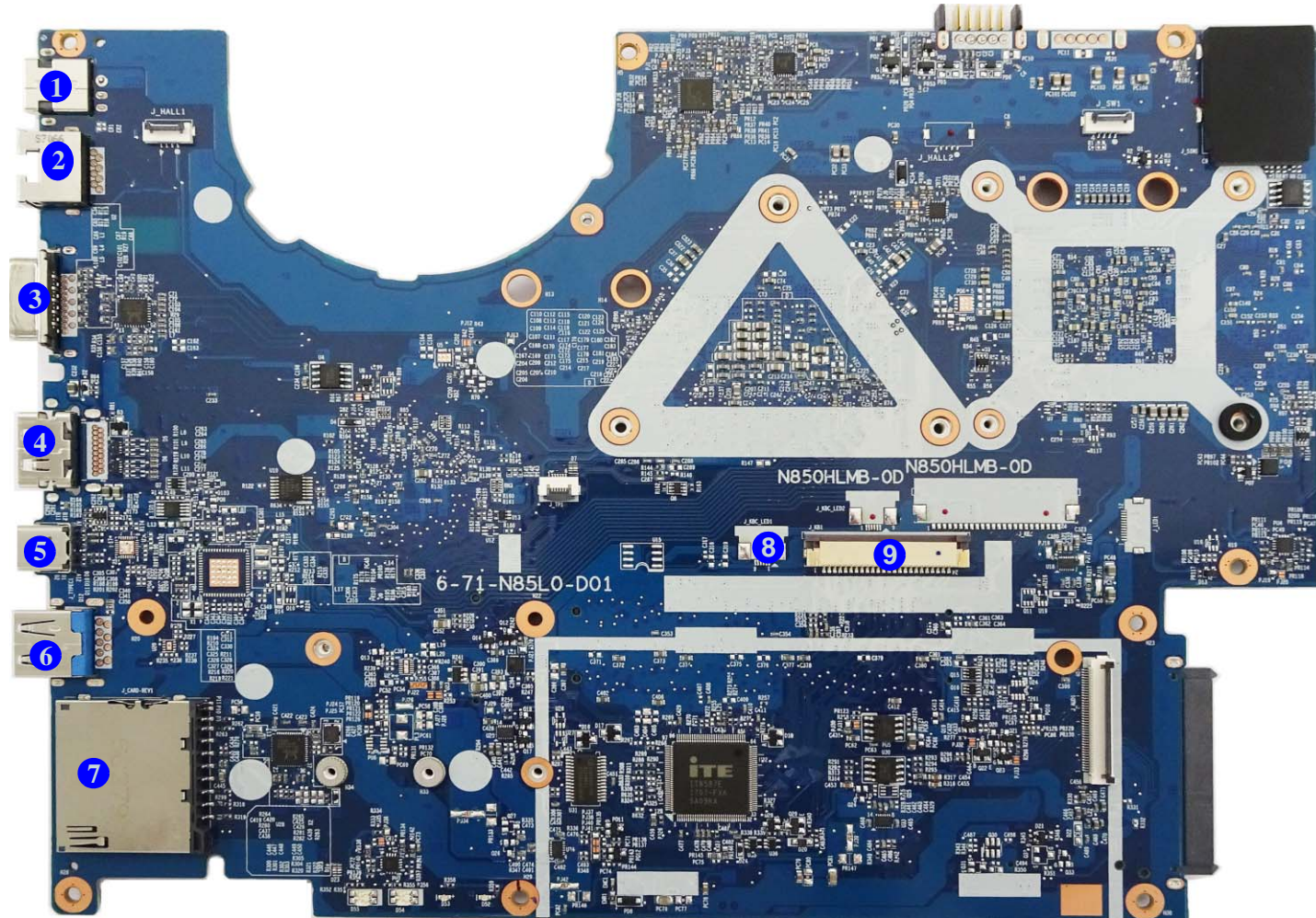

Mainboard Overview - Bottom (Connectors)

Figure 10
**Mainboard Bottom
Connectors**

1. CCD Connector
2. Fan Connector
3. HDD Connector
4. Speaker Connector
5. LCD Connector

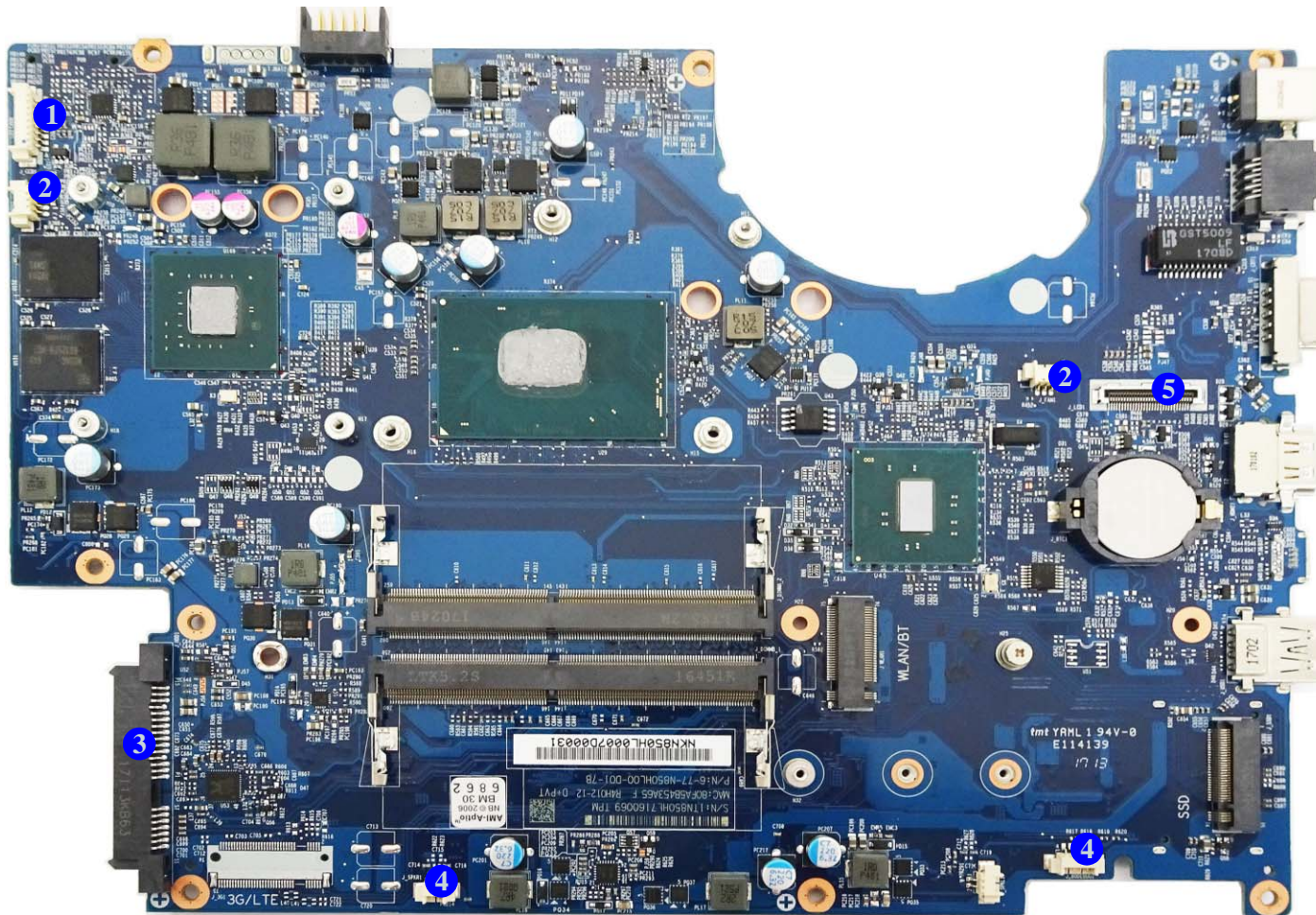

Chapter 2: Disassembly

Overview

This chapter provides step-by-step instructions for disassembling the *N850HL* series notebook's parts and subsystems. When it comes to reassembly, reverse the procedures (unless otherwise indicated).

We suggest you completely review any procedure before you take the computer apart.

Procedures such as upgrading/replacing the RAM, optical device and hard disk are included in the User's Manual but are repeated here for your convenience.

To make the disassembly process easier each section may have a box in the page margin. Information contained under the figure # will give a synopsis of the sequence of procedures involved in the disassembly procedure. A box with a  lists the relevant parts you will have after the disassembly process is complete. **Note:** The parts listed will be for the disassembly procedure listed ONLY, and not any previous disassembly step(s) required. Refer to the part list for the previous disassembly procedure. The amount of screws you should be left with will be listed here also.

A box with a  will also provide any possible helpful information. A box with a  contains warnings.

An example of these types of boxes are shown in the sidebar.

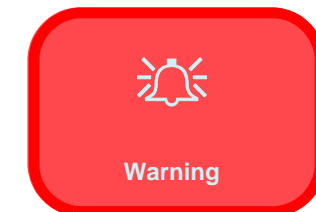
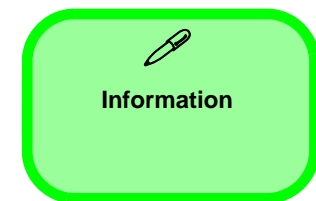

Disassembly

NOTE: All disassembly procedures assume that the system is turned **OFF**, and disconnected from any power supply (the battery is removed too).

Maintenance Tools

The following tools are recommended when working on the notebook PC:

- M3 Philips-head screwdriver
- M2.5 Philips-head screwdriver (magnetized)
- M2 Philips-head screwdriver
- Small flat-head screwdriver
- Pair of needle-nose pliers
- Anti-static wrist-strap

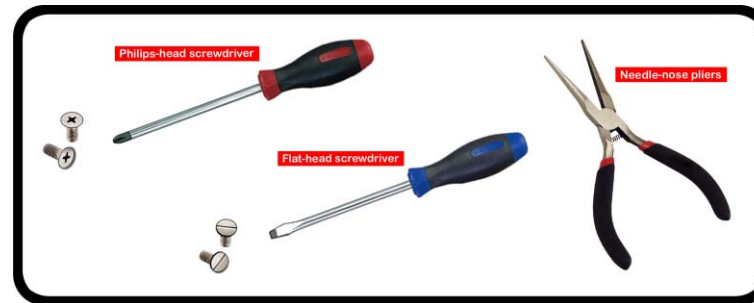

Connections

Connections within the computer are one of four types:

Locking collar sockets for ribbon connectors

To release these connectors, use a small flat-head screwdriver to gently pry the locking collar away from its base. When replacing the connection, make sure the connector is oriented in the same way. The pin1 side is usually not indicated.

Pressure sockets for multi-wire connectors

To release this connector type, grasp it at its head and gently rock it from side to side as you pull it out. Do not pull on the wires themselves. When replacing the connection, do not try to force it. The socket only fits one way.

Pressure sockets for ribbon connectors

To release these connectors, use a small pair of needle-nose pliers to gently lift the connector away from its socket. When replacing the connection, make sure the connector is oriented in the same way. The pin1 side is usually not indicated.

Board-to-board or multi-pin sockets

To separate the boards, gently rock them from side to side as you pull them apart. If the connection is very tight, use a small flat-head screwdriver - use just enough force to start.

Maintenance Precautions

The following precautions are a reminder. To avoid personal injury or damage to the computer while performing a removal and/or replacement job, take the following precautions:

1. **Don't drop it.** Perform your repairs and/or upgrades on a stable surface. If the computer falls, the case and other components could be damaged.
2. **Don't overheat it.** Note the proximity of any heating elements. Keep the computer out of direct sunlight.
3. **Avoid interference.** Note the proximity of any high capacity transformers, electric motors, and other strong magnetic fields. These can hinder proper performance and damage components and/or data. You should also monitor the position of magnetized tools (i.e. screwdrivers).
4. **Keep it dry.** This is an electrical appliance. If water or any other liquid gets into it, the computer could be badly damaged.
5. **Be careful with power.** Avoid accidental shocks, discharges or explosions.
 - Before removing or servicing any part from the computer, turn the computer off and detach any power supplies.
 - When you want to unplug the power cord or any cable/wire, be sure to disconnect it by the plug head. Do not pull on the wire.
6. **Peripherals** – Turn off and detach any peripherals.
7. **Beware of static discharge.** ICs, such as the CPU and main support chips, are vulnerable to static electricity. Before handling any part in the computer, discharge any static electricity inside the computer. When handling a printed circuit board, do not use gloves or other materials which allow static electricity buildup. We suggest that you use an anti-static wrist strap instead.
8. **Beware of corrosion.** As you perform your job, avoid touching any connector leads. Even the cleanest hands produce oils which can attract corrosive elements.
9. **Keep your work environment clean.** Tobacco smoke, dust or other air-borne particulate matter is often attracted to charged surfaces, reducing performance.
10. **Keep track of the components.** When removing or replacing any part, be careful not to leave small parts, such as screws, loose inside the computer.

Cleaning

Do not apply cleaner directly to the computer, use a soft clean cloth.

Do not use volatile (petroleum distillates) or abrasive cleaners on any part of the computer.

(For Computer Models Supplied with Light Blue Cleaning Cloth) Some computer models in this series come supplied with a light blue cleaning cloth. To clean the computer case with this cloth follow the instructions below.

- Power off the computer and peripherals.
- Disconnect the AC/DC adapter from the computer.
- Use a little water to dampen the cloth slightly.
- Clean the computer case with the cloth.
- Dry the computer with a dry cloth, or allow it time to dry before turning on.
- Reconnect the AC/DC adapter and turn the computer on.



Power Safety Warning

Before you undertake any upgrade procedures, make sure that you have turned off the power, and disconnected all peripherals and cables (including telephone lines and power cord). It is advisable to also remove your battery in order to prevent accidentally turning the machine on.

Disassembly Steps

The following table lists the disassembly steps, and on which page to find the related information. **PLEASE PERFORM THE DISASSEMBLY STEPS IN THE ORDER INDICATED.**

To remove the Battery:

1. Remove the battery [page 2 - 5](#)

To remove the Keyboard:

1. Remove the keyboard [page 2 - 6](#)

To remove the HDD:

1. Remove the battery [page 2 - 5](#)
2. Remove the HDD [page 2 - 7](#)

To remove the System Memory:

1. Remove the battery [page 2 - 5](#)
2. Remove the HDD [page 2 - 7](#)
3. Remove the system memory [page 2 - 9](#)

To remove the M.2 SSD:

1. Remove the battery [page 2 - 5](#)
2. Remove the HDD [page 2 - 7](#)
3. Remove the SSD [page 2 - 10](#)

To remove the Wireless LAN Module:

1. Remove the battery [page 2 - 5](#)
2. Remove the HDD [page 2 - 7](#)
3. Remove the WLAN [page 2 - 11](#)

To remove the 3G Module:

1. Remove the battery [page 2 - 5](#)
2. Remove the HDD [page 2 - 7](#)
3. Remove the 3G [page 2 - 13](#)

To remove the CCD Module:

1. Remove the battery [page 2 - 5](#)
2. Remove the HDD [page 2 - 7](#)
3. Remove the CCD module [page 2 - 14](#)

Removing the Battery

1. Turn the computer **off**, and turn it over.
2. Slide the latch **1** in the direction of the arrow (*Figure 1a*).
3. Slide the latch **2** in the direction of the arrow.
4. While holding the latch **2**, lift the battery **3** (*Figure 1b*) out of the compartment (*Figure 1c*).

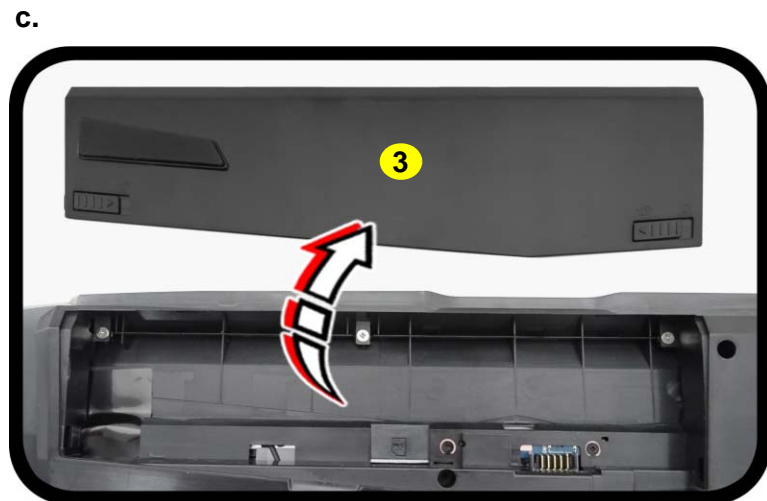
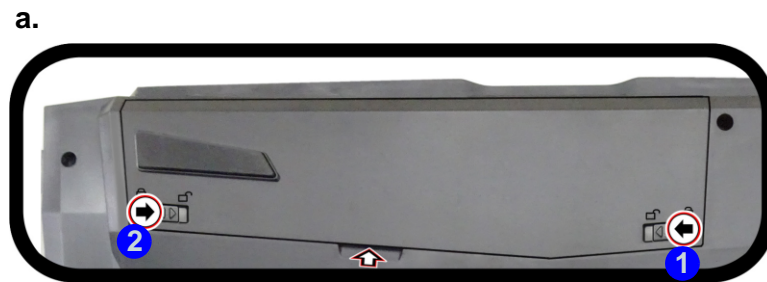
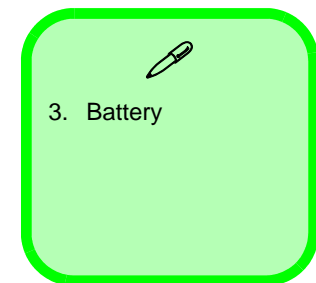

Figure 1
Battery Removal

- a. Slide the latch **1** in the direction of the arrow, and slide the latch **2** in the direction of the arrow.
- b. Lift the battery.
- c. Remove the battery.



Disassembly

Figure 2

Keyboard Removal

- Remove the screws from the bottom of the computer and then eject the keyboard using a special eject stick to push the keyboard out while releasing the keyboard as shown.
- Lift the keyboard up and disconnect the keyboard ribbon cable from the locking collar socket.
- Remove the keyboard.

Removing the Keyboard

- Turn **off** the computer, turn it over.
- Remove screws **1** - **2** from the bottom of the computer.
- Open it up with the LCD on a flat surface before pressing at point **3** to release the keyboard module (use the special eject stick **4** to do this) while releasing the keyboard in the direction of the arrow **5** as shown (**Figure 2a**).
- Carefully lift the keyboard **6** up, being careful not to bend the keyboard ribbon cable **7**. Disconnect the keyboard ribbon cable **7** from the locking collar socket by using a flat-head screwdriver to pry the locking collar pins **8** away from the base (**Figure 2b**).
- Carefully lift the keyboard **6** off the computer (**Figure 2c**).

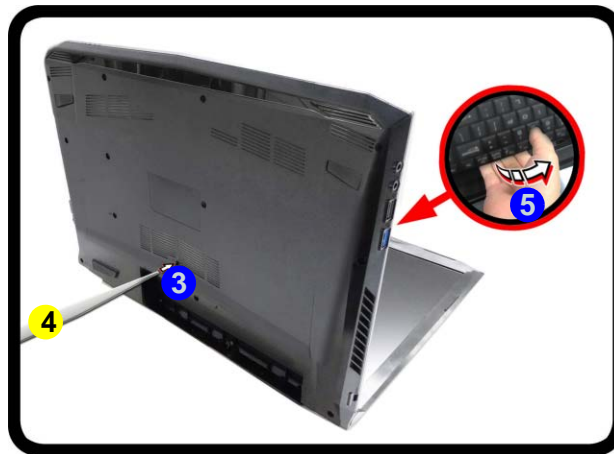
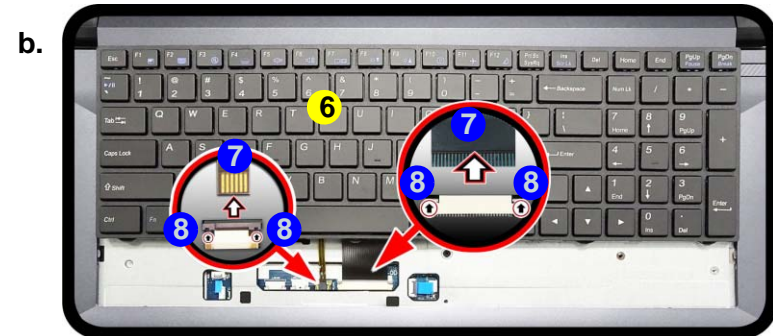
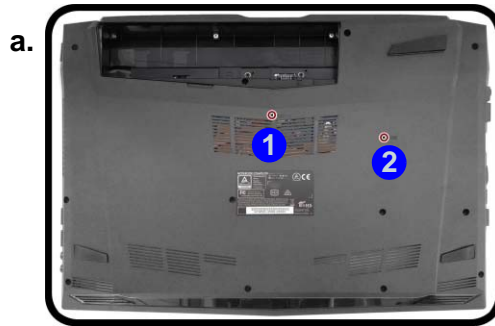

Re-inserting the Keyboard

When re-inserting the keyboard firstly, align the keyboard tabs at the bottom of the keyboard with the slots in the case.



- Eject Stick
- Keyboard

- 2 Screws

Removing the Hard Disk Drive

The hard disk drive can be taken out to accommodate other 2.5" serial (SATA) hard disk drives with a height of 7mm (h). Follow your operating system's installation instructions, and install all necessary drivers and utilities (as outlined in **Chapter 4 of the User's Manual**) when setting up a new hard disk.

Hard Disk Disassembly Process

1. Turn **off** the computer, and remove the battery ([page 2 - 5](#)).
2. Remove the SD card cover **1** and screws **2 - 18** ([Figure 3a](#)).
3. Carefully push to release the bottom case **19** from point **20** and then lift it up from point **21** to release the bottom case and ports as indicated by the arrows ([Figure 3b](#)).
4. The HDD will be visible at point **22** on the mainboard ([Figure 3c](#)).

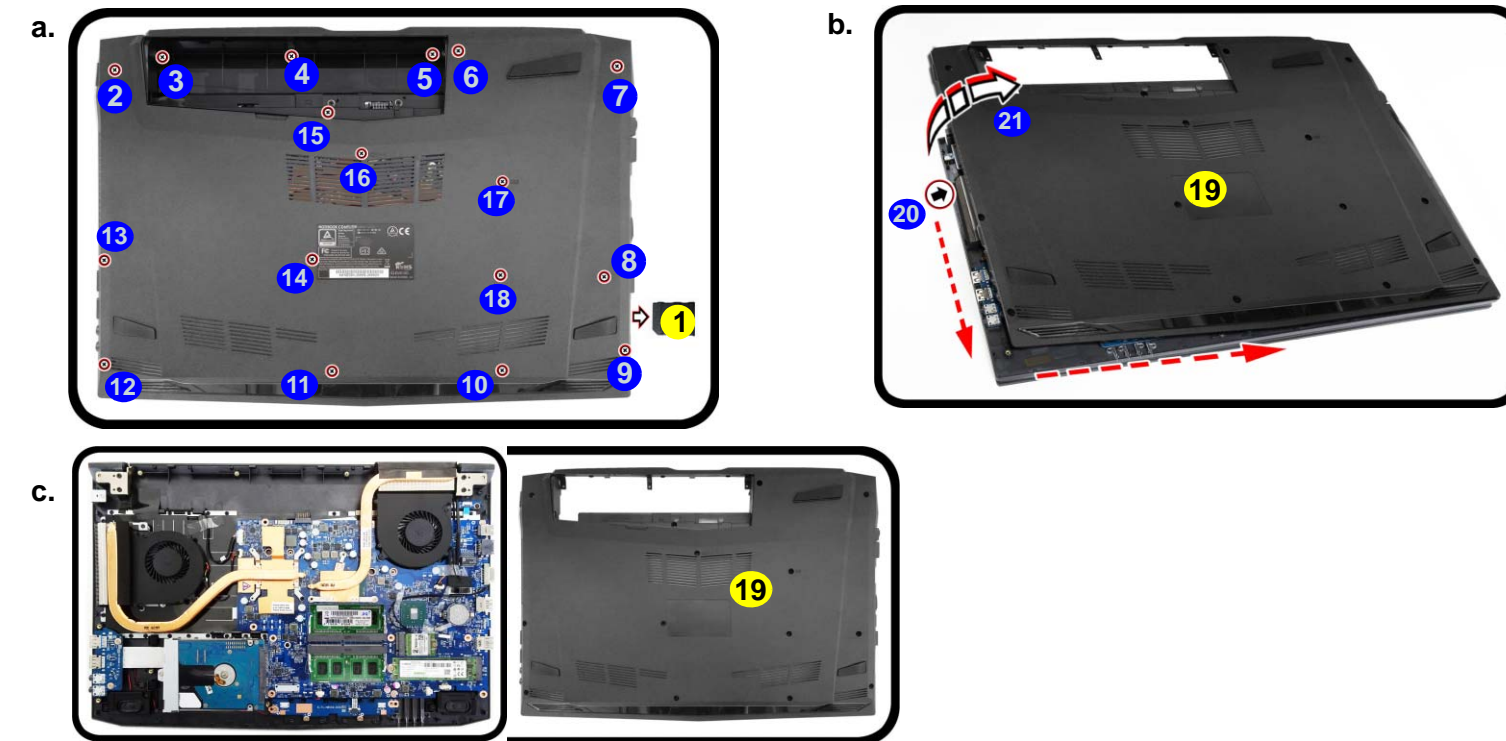

Figure 3
HDD Assembly Removal

- a. Remove the SD card cover and screws.
- b. Remove the bottom case.
- c. Locate the HDD.



Powering the Computer On

After every disassembly, make sure that the bottom case's screws are all inserted and tightened before turning the computer on.



22. Hard Disk

- 17 Screws

Disassembly

Figure 4
**HDD Assembly
 Removal (cont'd.)**

- d. Remove the screws.
 e. Slightly lift and pull the HDD in the direction of the arrow.
 f. Lift the HDD assembly out of the bay.
 g. Remove the screws and bracket from the HDD.

5. Remove screws 23 from the HDD assembly (*Figure 4d*).
 6. Slightly lift and pull the hard disk assembly in the direction of arrow 24 (*Figure 4e*).
 7. Lift the hard disk assembly 25 out of the bay 26 (*Figure 4f*).
 8. Remove screws 27 - 28 and bracket 29 from the hard disk 30 (*Figure 4g*).
 9. Reverse the process to install a new hard disk (do not forget to replace the screws).

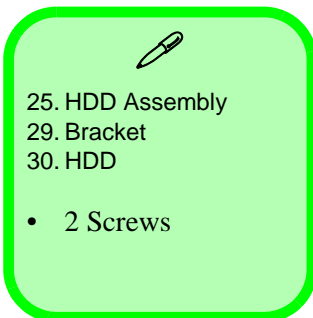
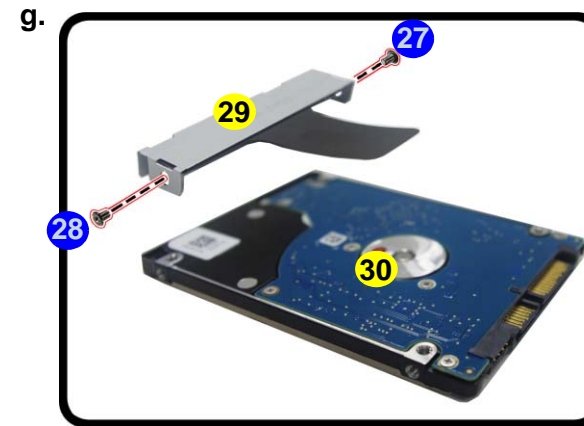
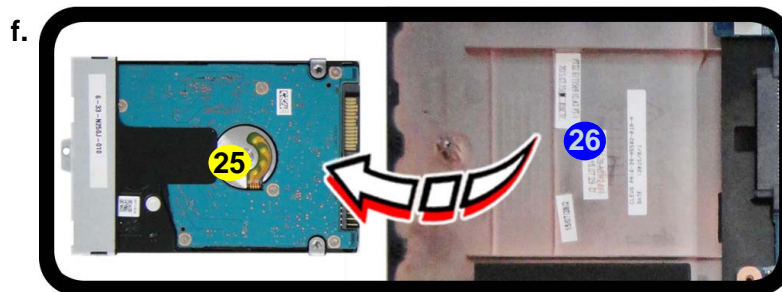
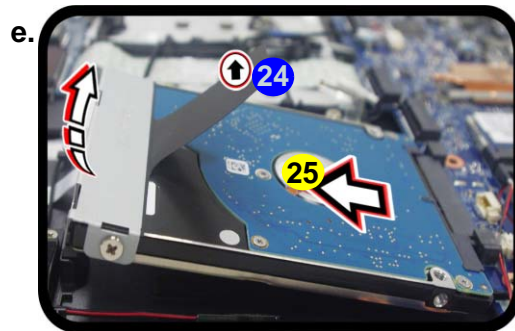



HDD System Warning

New HDD's are blank. Before you begin make sure:

- You have backed up any data you want to keep from your old HDD.
- You have all the CD-ROMs and FDDs required to install your operating system and programs.
- If you have access to the internet, download the latest application and hardware driver updates for the operating system you plan to install. Copy these to a removable medium.

Removing the System Memory (RAM)

The computer has two memory sockets for 260 pin Small Outline Dual In-line Memory Modules (SO-DIMM) supporting DDR4 2400 MHz. The main memory can be expanded up to 16GB. The total memory size is automatically detected by the POST routine once you turn on your computer.

Memory Upgrade Process

1. Turn **off** the computer, turn it over, remove the battery ([page 2 - 5](#)).
2. The RAM-2 modules will be visible at point **1** on the mainboard ([Figure 5a](#)).
3. Gently pull the two release latches (**2** & **3**) on the sides of the memory socket in the direction indicated by the arrows ([Figure 5b](#)). The RAM module **4** will pop-up ([Figure 5c](#)), and you can then remove it.
4. Pull the latches to release the second module if necessary.
5. Insert a new module holding it at about a 30° angle and fit the connectors firmly into the memory slot.
6. The module will only fit one way as defined by its pin alignment. Make sure the module is seated as far into the slot as it will go. **DO NOT FORCE IT**; it should fit without much pressure.
7. Press the module in and down towards the mainboard until the slot levers click into place to secure the module.
8. Replace the bottom cover and the screws (see [page 2 - 7](#)).
9. Restart the computer to allow the BIOS to register the new memory configuration as it starts up.

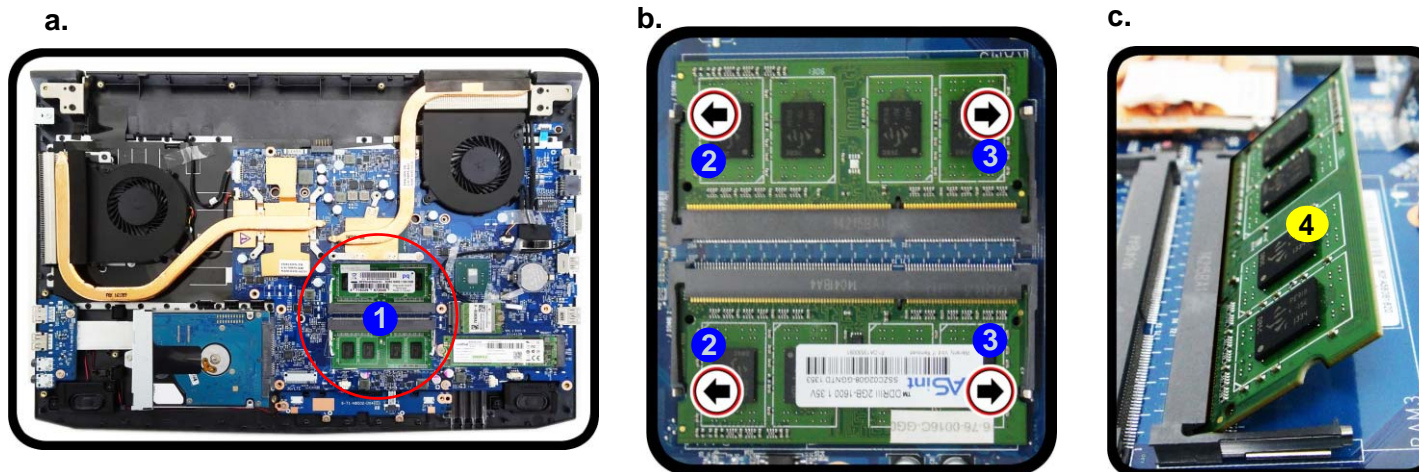

Figure 5
RAM Module Removal

- a. The RAM modules will be visible at point **1** on the mainboard.
- b. Pull the release latches.
- c. Remove the module.



Contact Warning

Be careful not to touch the metal pins on the module's connecting edge. Even the cleanest hands have oils which can attract particles, and degrade the module's performance.



4. RAM Module

Disassembly

Figure 6
M.2 SSD Module
Removal

- a. Locate the M.2 SSD.
- b. Remove the screw.
- c. The M.2 SSD module will pop up.

Removing and Installing the M.2 SSD Module

M.2 SSD Module Removal Procedure

1. Turn off the computer, turn it over, remove the battery ([page 2 - 5](#)).
2. The M.2 SSD module will be visible at point **1** on the mainboard ([Figure 6a](#)).
3. Remove the screw **2** ([Figure 6b](#)).
4. The M.2 SSD module **3** ([Figure 6c](#)) will pop-up, and you can remove it from the computer.

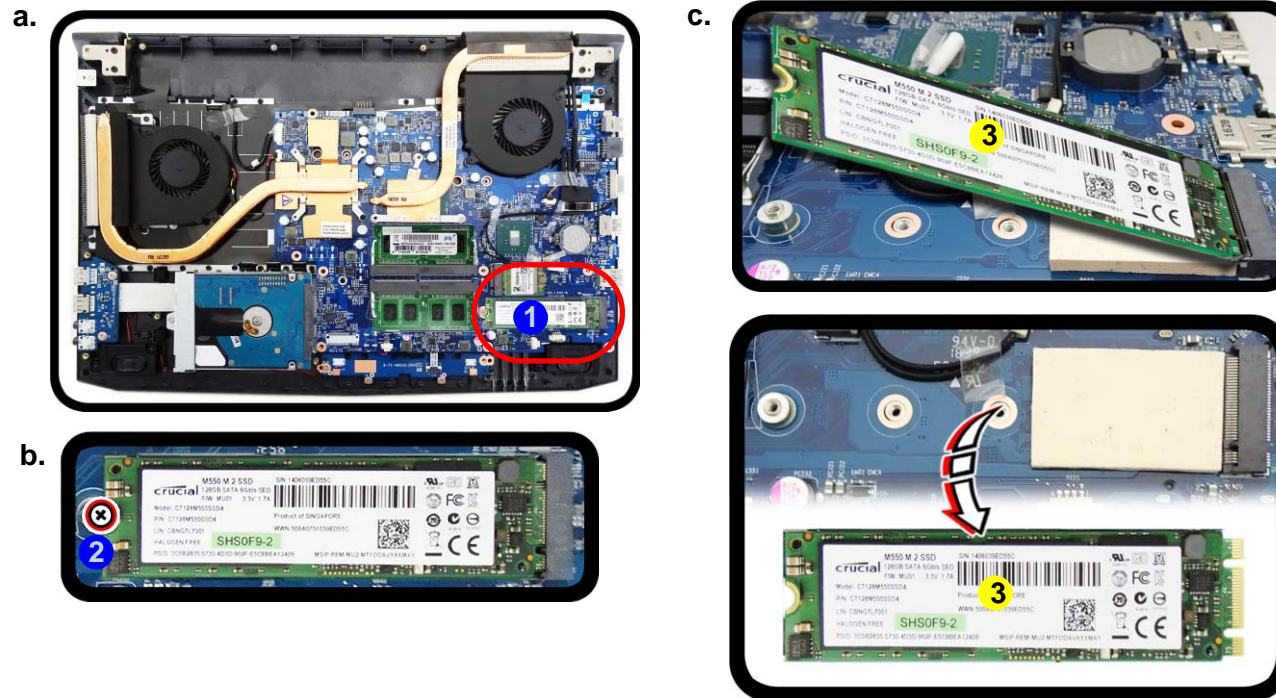

3.M2 SSD Module

- 1 Screw

Removing the Wireless LAN Module

1. Turn **off** the computer, turn it over, remove the battery ([page 2 - 5](#)).
2. The Wireless LAN module will be visible at point **1** on the mainboard ([Figure 7a](#)).
3. Carefully disconnect the cables **2** & **3**, and then remove the screw **4** ([Figure 7b](#)).
4. The Wireless LAN module **5** ([Figure 7c](#)) will pop-up, and you can remove it from the computer.

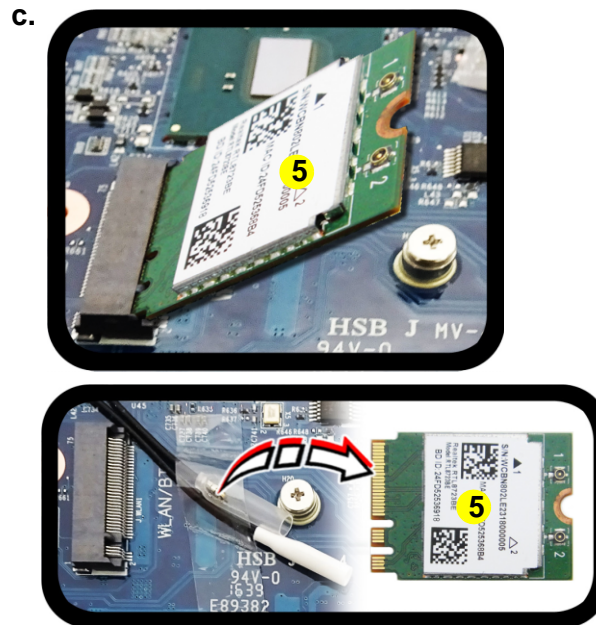
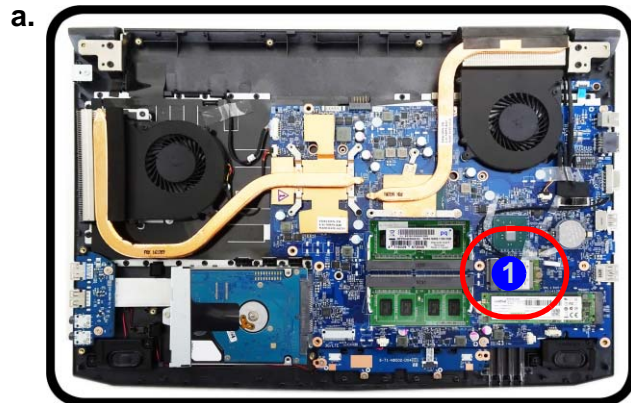



Figure 7
**Wireless LAN
Module Removal**

- a. Locate the WLAN.
- b. Disconnect the cables and remove the screw.
- c. The WLAN module will pop up.

Note: Make sure you reconnect the antenna cable to the “1 + 2” socket ([Figure 7b](#)).



5. Wireless LAN Module

- 1 Screw

Wireless LAN, Combo, 3G & LTE Module Cables

Note that the cables for connecting to the antennae on WLAN, WLAN & Bluetooth Combo, 3G and LTE modules are not labelled. The cables/covers (each cable will have either a black or transparent cable cover) are color coded for identification as outlined in the table below.

Module Type	Antenna Type	Cable Color	Cable Cover Type
WLAN/WLAN & Bluetooth Combo	WM 1	Black	Transparent
	WM 2	Black	White
LTE Broadband	LTE 1	Black	Black
	LTE 2	Black	Blue

Cable 1 is usually connected to antenna 1 (Main) on the module, and cable 2 to antenna 2 (Aux).

Removing the 3G Module

3G Module Removal Procedure

1. Turn **off** the computer, remove the battery ([page 2 - 5](#)).
2. Locate the module, it is visible at point **1** ([Figure 8a](#)).
3. Carefully disconnect the cables **2** & **3**, and then remove the screw **4** from the module ([Figure 8b](#)).
4. The module **5** will pop-up ([Figure 8c](#)).
5. Lift the module **5** up and off the computer ([Figure 8d](#)).

Figure 8
3G Module Removal

- a. Locate the module.
- b. Disconnect the cables and remove the screw.
- c. The module will pop-up.
- d. Lift the module up off the socket.



5. 3G Module

- 1 Screw

Disassembly

Figure 9
CCD Removal

- a. Remove rubber and screws and then carefully release the inner frame of the LCD panel at the points indicated by the arrows.
- b. Remove the LCD front cover.

Removing the CCD

1. Turn **off** the computer, turn it over to remove the battery ([page 2 - 5](#)).
2. Lay the computer down on a flat surface with the top case up forming a 90 degree angle. Carefully remove the rubber covers **1** - **2** and screws **3** - **4**.
3. Run your fingers around the inner frame of the LCD panel to lift at the upper point **5** as indicated by the arrows, and slightly push and lift up the inner frame at the middle points **6** - **7** as indicated by the arrows, and then run your fingers around the inner frame at the lower point **8** as indicated by the arrows ([Figure 9a](#)).
4. Remove the LCD front cover **5** ([Figure 9b](#)).

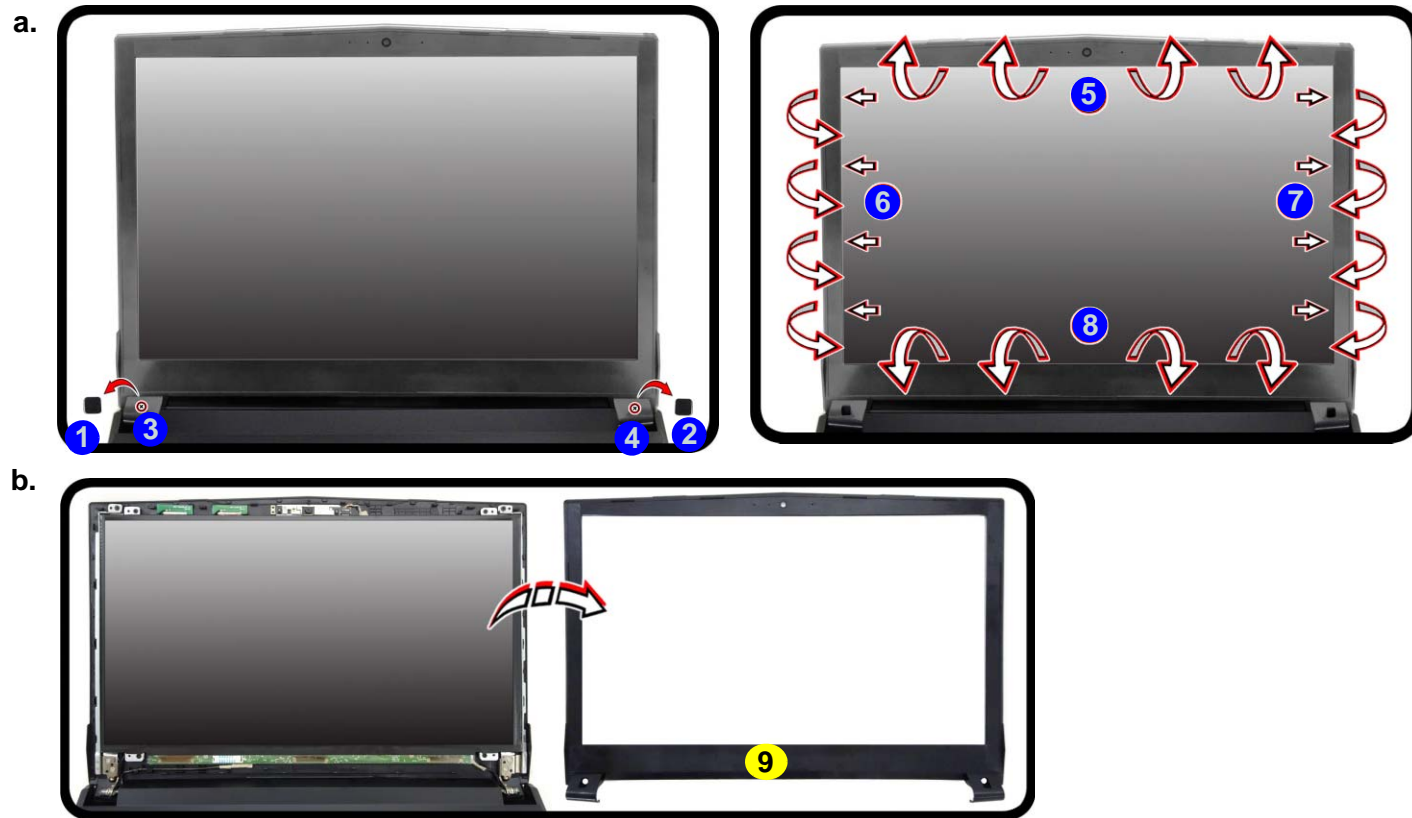

9. LCD Front Cover

- 2 Screws

5. Disconnect the cable **10** (*Figure 10c*).
6. Remove the CCD module **11** (*Figure 10d*).
7. Reverse the process to install a new CCD module.



Figure 10
CCD Removal
(cont'd)

- c. Disconnect the cable.
- d. Remove the CCD module.

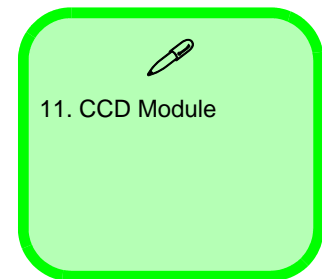

Appendix A:Part Lists

This appendix breaks down the *N850HL* series notebook's construction into a series of illustrations. The component part numbers are indicated in the tables opposite the drawings.

Note: This section indicates the *manufacturer's* part numbers. Your organization may use a different system, so be sure to cross-check any relevant documentation.

Note: Some assemblies may have parts in common (especially screws). However, the part lists DO NOT indicate the total number of duplicated parts used.

Note: Be sure to check any update notices. The parts shown in these illustrations are appropriate for the system at the time of publication. Over the product life, some parts may be improved or re-configured, resulting in *new* part numbers.

Part List Illustration Location

The following table indicates where to find the appropriate part list illustration.

Table A - 1
**Part List Illustration
Location**

Part	
Top	<i>page A - 3</i>
Bottom	<i>page A - 4</i>
Main Board	<i>page A - 5</i>
HDD	<i>page A - 6</i>
LCD	<i>page A - 7</i>

Top

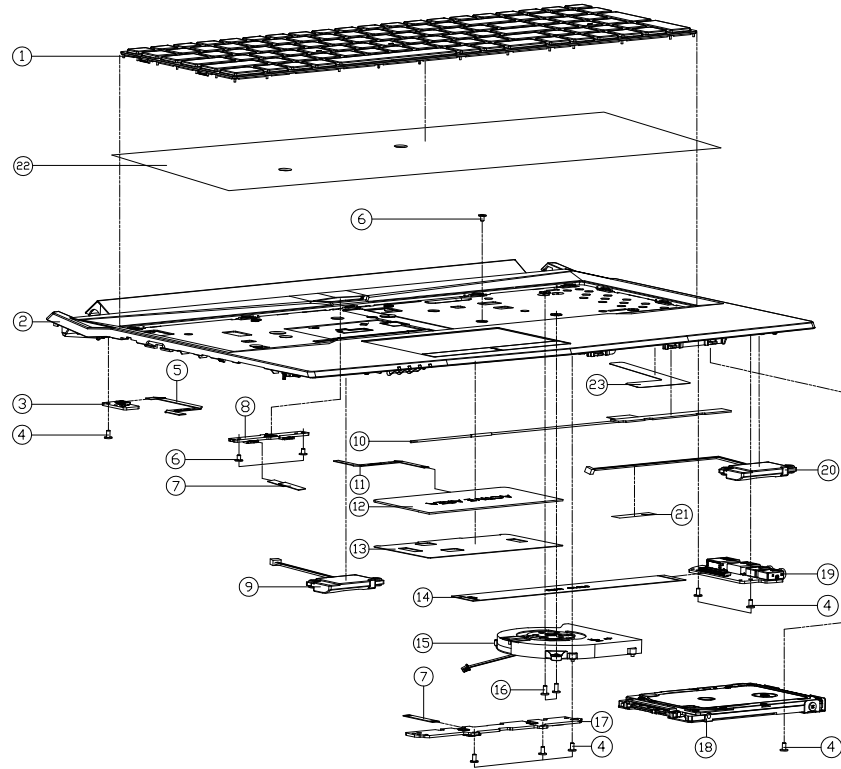

ITEM	PART NAME	PART NO	REMARK
1	WHITE BL. KD USA CMV5F3035-430 N850J BLACK ISOLATION WITH WINO KEY + KB FRAME	6-80-N7500-012-1	FOR WHITE BL. SERIES
1	KB USA CMV5F3035-430 N850J BLACK ISOLATION WITH WINO KEY	6-80-N25J0-011-1	FOR PA SERIES
2	TOP CASE MODULE(W/ BACK LIGHT) N850HC	6-39-N8502-014	FOR N850HC/N857HC FOR N850HL/N857HL
2	TOP CASE MODULE(W/BACK LIGHT)(W/FP) N850HJ	6-39-N85H2-022	FOR N850HN
3	HALL SENSOR BOARD V4.0 N850HC	6-77-N8501-D04	
3	HALL SENSOR BOARD V4.0 N850HC	6-77-N8501-D03A	
4	SCREW M2*4L KI NI ICT NY (DD=04.5,DT=0.4)	6-35-B1120-4RE	
5	FFC CABLE HALLSENSOR TO MB L=90MM 3V 4PIN N850HC(CX)	6-43-N8500-031-1	
6	SCREW M2*3L KI BZ ICT NY (DD=04.5,DT=0.4)	6-35-B6120-3RD	
7	FFC CABLE POWER-CLICK TO MB L=40MM 3V 4PIN N850HC(CX)	6-43-N8500-021-1	
8	POWER SW BOARD V3.0 N850HC	6-77-N850S-D03	
9	SPK+CABLE L 23*44 15W 4T 25MM L1254X0P (OVD) N850U (AOD RUBBER)	6-23-5N250-1L2	
10	ANTENNA PENN LITE V01 LITE PCB BL. L060X065X065X065 LITE - 15MM N850V	6-23-7N350-021	
11	FFC CABLE TP TO MB L=78MM 3V 6PIN N850HC(CX)	6-43-N8500-011-2	
12	TOUCH PAD SYNAPTICS PTP TM-6389-002 (ODD#55M) V650HC	6-49-W65D3-010	
13	TOP TP MYLAR PET N250LU	6-40-N2502-040	
14	FFC CABLE AUDIO TO MB L=159MM 5V 40PIN N850HC(CX)	6-43-N8500-041-2	
15	CPU FAN MODULE (FORCECON) N550RC	6-31-N5502-103	
16	SCREW M2*5L KI(CT=0.8 D=4.0) BK/Z ICT NY	6-35-B6120-5R0	
17	CLICK BOARD V4.0A N850HC	6-77-N8502-D04A	
18	W/O HDD ASS'Y N850HC	6-79-N850HC0J-010	
18	W/ HDD ASS'Y N850HC	6-79-N850HC0J-020	
19	AUDIO BOARD V3.0 N850HC	6-77-N8508-D03	
20	SPK+CABLE R 23*44 15W 4T 25MM L1254X0P (OVD) N850U (AOD RUBBER)	6-23-5N250-1R2	
21	TAPE MYLAR (C),MYLAR M550J	6-40-M55J2-030	
22	MYLAR+CR4382 (340.95*105.6*0.41)FOR KB N850HC	6-40-N8502-060	FOR PA SERIES
23	AL FOIL (73*37*0.1) N850HC	6-47-N8502-010	

Figure A - 1
Top

Bottom

Figure A - 2
Bottom

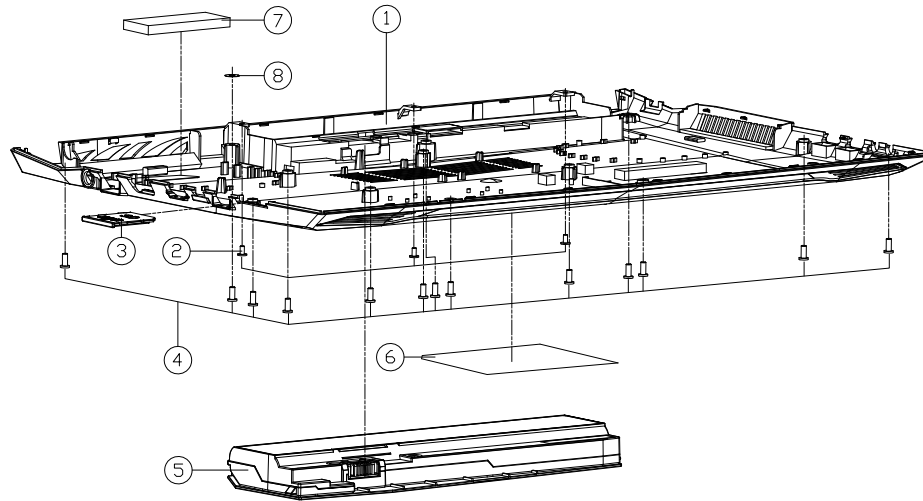

ITEM	PART NAME	PART NO	REMARK
1	BOTTOM CASE MODULE(CMP) N850HC	6-39-N8503-012	
2	SCREW M2*4L KI NI ICT NY (DD=44.5,DT=0.4)	6-35-B1120-4RE	
3	DUMMY SD PUSH PUSH TYPE PC+ABS (72230P-700E) W9705UW	6-42-W9708-011	
4	SCREW M2.5*6L K BZ ICT NY	6-35-82125-6RA	
5	WAF S LU 111V/SAN/20W SEP 0P/ALC (EXTD) OIL RESIST 901/125F NEG/IC	6-87-N850S-6E71	
5	WAF S LU 111V/SAN/20W SEP 0P/ALC/20MM (EXTD) OIL RESIST/901/125F NEG/IC	6-87-N850S-6U71	
5	WAF S LU 111V/SAN/20W SEP 0P/ALC/20MM (EXTD) P/ALC/OIL RESIST/901/125F NEG/IC	6-87-N850S-4U41	
5	WAF S LU 111V/SAN/20W SEP 0P/ALC (EXTD) P/ALC/OIL RESIST 901/125F NEG/IC	6-87-N85HS-41C00	
6	PRODUCT LABEL FOR N857HL	6-45-N857HL03-010	
6	PRODUCT LABEL FOR N850HL	6-45-N850HL03-010	
7	BOTTOM CASE SPONGE(60*20*6T) SM55+G9000 N850HL	6-47-0019A-60M	
8	WASHER #6*4*0.6t ONYLARD FOR 3X3/C LLD011U/HT14X12	6-37-02000-603	

Main Board

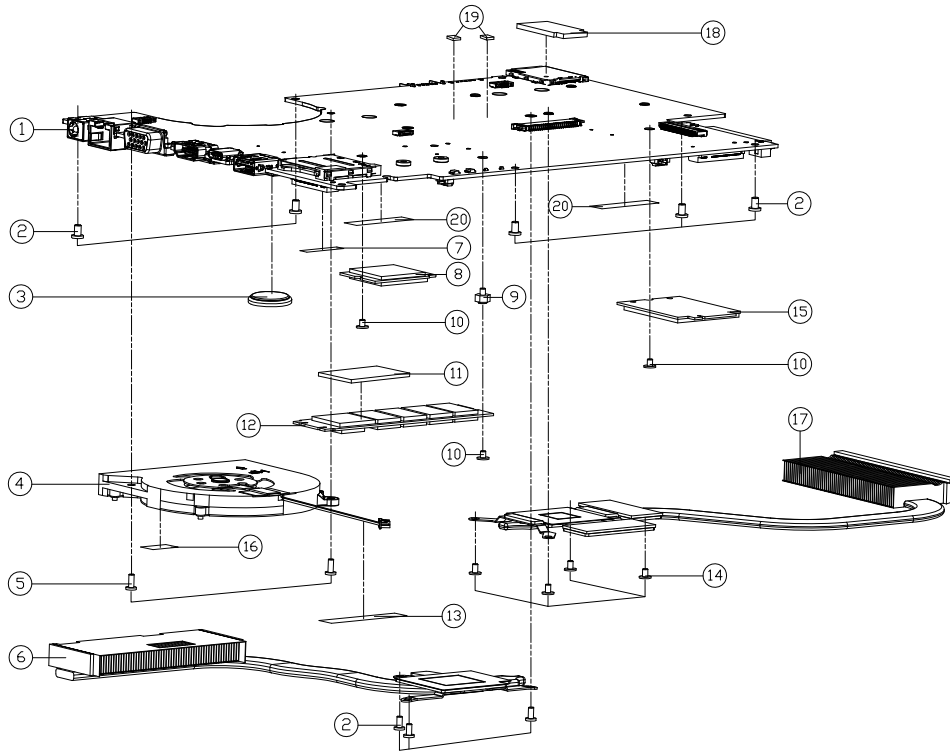

ITEM	PART NAME	PART NO	REMARK
1	MAIN BOARD CPU V17-7700A/280 VIA CEPWA/TPLTE/JSSBJL/KD NEGHL	6-77-N850HL00-D01-A	
1	MAIN BOARD CPU V17-7700A/280 VIA CEPWA/TPLTE/JSSBJL/KD NEGHL	6-77-N850HL00-D01-2A	
1	MAIN BOARD CPU V17-7700A/280 VIA CEPWA/TPLTE/JSSBJL/KD NEGHL	6-77-N850HL00-D01-14C	
1	MAIN BOARD CPU V17-7700A/280 VIA CEPWA/TPLTE/JSSBJL/KD NEGHL	6-77-N850HL00-D01-14B	
1	MAIN BOARD CPU V17-7700A/280 VIA CEPWA/TPLTE/JSSBJL/KD NEGHL	6-77-N850HL00-D01-14A	
1	MAIN BOARD CPU V17-7700A/280 VIA CEPWA/TPLTE/JSSBJL/KD NEGHL	6-77-N850HL00-D01-7B	
1	MAIN BOARD CPU V17-7700A/280 VIA CEPWA/TPLTE/JSSBJL/KD NEGHL	6-77-N850HL00-D01-15C	
2	.SCREW M2.5*4L KI NI ICT NY	6-35-21125-4R0	
3	BATTERY 3V 220MA BBBCR2032B (KTS)	6-23-6A2B2-030	
4	CPU FAN MODULE (FORCECOOL) N550RC	6-31-N5502-102	
5	SCREW M2*5L K1CT=0.8 D=4.0 BK/Z ICT NY	6-35-B6120-5R0	
6	CPU HEATSINK MODULE N850HL	6-31-N85LN-201	
7	TOP CASE MYLAR FR83 25*7*0.05 P180HM	6-40-W25P3-010	
8	ALUMI CARD DUAL BAND INTEL SIM9000 INI REHT 042 R2 220 P580S	6-88-P65SF-4210	OPTION
8	ALUMI CARD DUAL BAND INTEL SIM9000 INI REHT 042 R2 220 P580S	6-88-P65SF-4200	OPTION
9	SCREW W/SHCS 0H-25 D=50 STEEL 1BT NY FDR NEFF CARDCARDER	6-35-ZA120-2R5-1	
10	SCREW M2*2L KI NI ICT NY (DD=0.5, T=0.5)	6-35-B1120-2R0	
11	THERMAL PAD R3300 (30*20*2.75)MM FDR R2 SSD N850HC	6-48-N850S-010	
12	SSD R2 2280 256GB SAMSUNG MVA V6E2MLP-1000 (PM9A1) PCIE GEN4 3D TLC	6-85-D515B-S05	OPTION
12	SSD R2 2280 256GB INTEL G6A89-256GB (G6A89) SATA3 0MLD	6-85-D51R6-400	OPTION
12	SSD R2 2280 256GB INTEL SSP9KXAS2671 60MP PCIE GEN4 3D TLC	6-85-D515B-200	OPTION
12	SSD R2 2280 256GB CRUCIAL CT250M2OSS4 0K2000 SATA3 MLC	6-85-D51R0-100	OPTION
13	TAPE MYLAR (A),MYLAR M550J	6-40-M55J2-010	
14	SCREW M2*4L KI NI ICT NY (DD=0.4, DT=0.4)	6-35-B1120-4RE	
15	WORM HAWK METAL MESH FOR CARD USB INTERFACE WITHOUT OPS SCENTU	6-88-S210W-8810	
15	LIE 46 HOLE METAL MESH FOR CARD USB INTERFACE WITHOUT OPS HOLEMS	6-88-N5506-8800	
15	LIE 46 OPS HOLE METAL MESH FOR CARD USB INTERFACE WITHOUT OPS HOLEMS	6-88-W3306-8830	
16	TAPE MYLAR TRANSPARENT (20*10*0.05) P180HM	6-40-P1803-020	
17	VGA HEATSINK MODULE N850HL	6-31-N85LN-101	
18	SIM RUBBER (SILICONE RUBBER-NITTON SEA) M265JU-V	6-47-N25J2-071-V	FDR W/D 3G/L/TE1 118-05
19	RUBBER SILICONE 6*6*2.3T N855HC	6-47-N8552-010	DONLY FDR N855HL
20	TAPE MYLAR (C),MYLAR M550J	6-40-M55J2-030	

Figure A - 3
Main Board

HDD

Figure A - 4
HDD

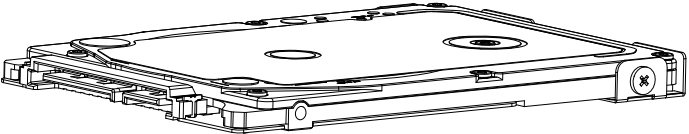
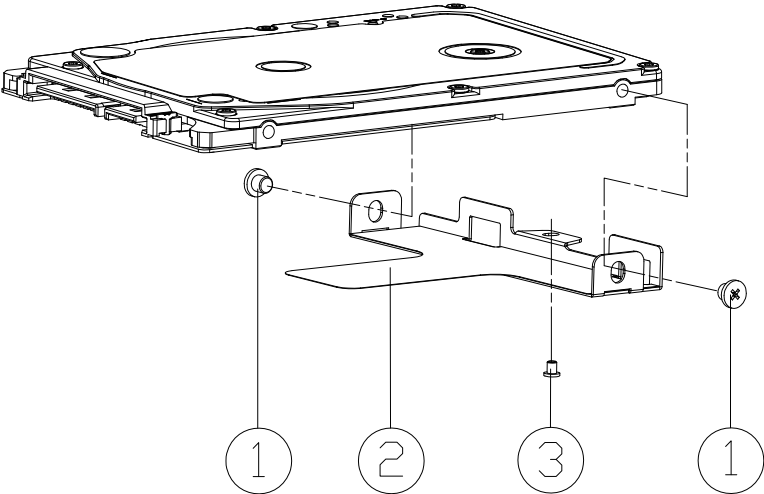

ITEM	PART NAME	PART NO	REMARK
1	SCREW M3*2.5L KI NI ICT NY	6-35-B1130-2R5	
2	HDD BKT 7MM SECC T=0.5 N250LU	6-33-N250J-011	
3	.SCREW M2*4L KI NI ICT NY (DD=Ø4.5,DT=0.4)	6-35-B1120-4RE	

LCD

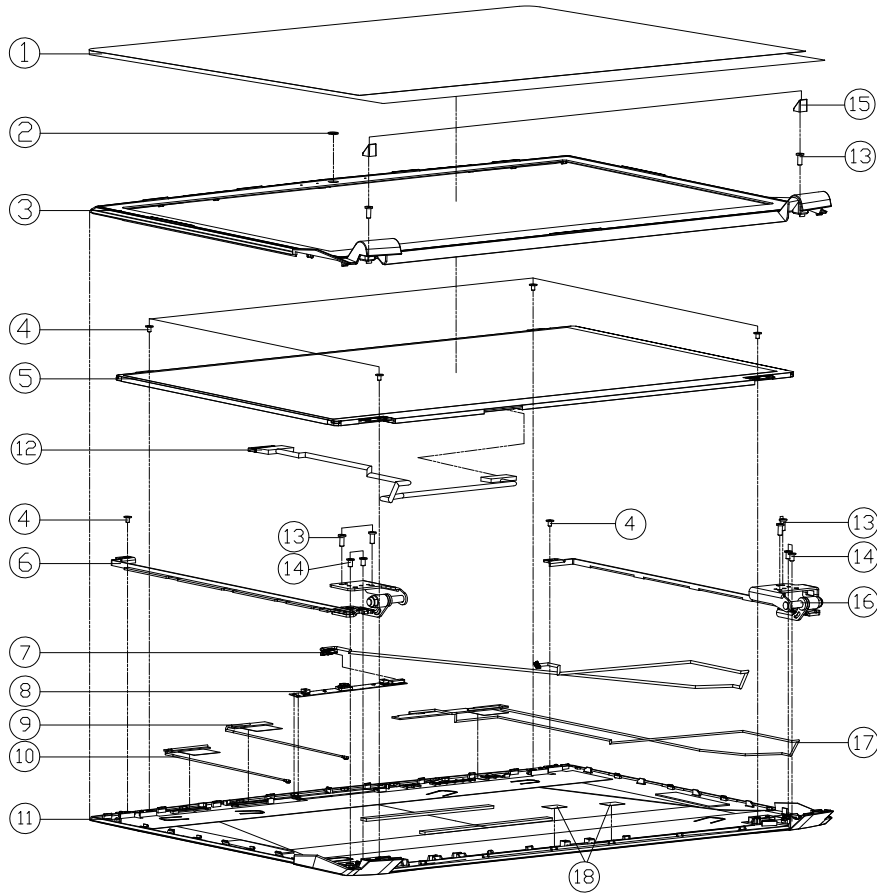

ITEM	PART NAME	PART NO	REMARK
1	LCD PROTECT MYLAR BOPP N650DU	6-40-N6508-040	
2	CCD LENS (VIEWING AREA 4MMXPMMA)W940TU	6-42-W9401-020-1	
3	LCD FRONT COVER MODULE (MP) N850HC	6-39-N8501-012	
4	SCREW M2x3L KI BZ ICT NY (DD=04.5,DT=0.4)	6-35-B6120-3RD	
5	LCD 15.6" FHD/IPS/VEIP LG LP156WV6-SPK3 0N4) (LED) 32MM	6-50-LB232-L08	
5	LED 15.6" FHD/IPS/VEIP LG LP156WV6-SPK3 0N4) (LED) 32MM	6-50-LB232-L04	
5	LCD 15.6" HD (CEDP) AU B156XTN03.5 (LED) 32MM	6-50-L8132-G03	
5	LCD 15.6" FHD (CEDP) INNELUX NESAGE-E48 (7/4) (UPDATED) LED 32 MM	6-50-LB232-V02	
5	LCD 15.6" HD (CEDP) LG LP156WHU-TPB1 (LED) 32 MM	6-50-L8132-L01	
5	LCD 15.6" HD (CEDP) AU B156XTN07.1 (32MM) LED	6-50-L8132-G04	
5	LCD 15.6" FHD/ EDP AU B156HTN03.8 (1/4/6B) LED 32MM	6-50-LB232-G18	
5	LCD 15.6" FHD/WVA/VA/AMIN G1/EDP AU B156HWMA4 (LED) 32MM	6-50-LB32-G010	
6	LCD HINGE L (SGCC+S50C) (MP) N850HC	6-33-N8501-0L2	
7	WIRE CABLE FOR CCD D-MIC 500MM 3.3V BP (CND) N250LU	6-43-N250T-011-2	
8	AVC CAMERA CROWN TX1 OPT/REVERSE/28 FHD DCPH NS30C FV30C W/WHITE-LED W/PC	6-88-W65DC-5110	OPTION
8	AVC CAMERA CROWN TX1 OPT/REVERSE/28 FHD DCPH NS30C FV30C W/WHITE-LED W/PC	6-88-N850C-5100	OPTION
8	AVC CAMERA CROWN TX1 DCPH/28 FHD DCPH NS30C FV30C W/WHITE-LED W/PC	6-88-N850C-4900	OPTION
8	AVC CAMERA CROWN TX1 OPT/REVERSE/28 FHD DCPH NS30C FV30C W/WHITE-LED W/PC	6-88-W51PC-5100	OPTION
8	AVC CAMERA CROWN TX1 DCPH/28 FHD DCPH NS30C FV30C W/WHITE-LED W/PC	6-88-N650C-4910	OPTION
8	AVC CAMERA CROWN TX1 OPT/REVERSE/28 FHD DCPH NS30C FV30C W/WHITE-LED W/PC	6-88-W65DC-5100	OPTION
8	AVC CAMERA CROWN TX1 OPT/REVERSE/28 FHD DCPH NS30C FV30C W/WHITE-LED W/PC	6-88-P775C-5100	OPTION
8	AVC CAMERA CROWN TX1 DCPH/28 FHD DCPH NS30C FV30C W/WHITE-LED W/PC	6-88-P775C-4901	OPTION
8	AVC CAMERA CROWN TX1 OPT/REVERSE/28 FHD DCPH NS30C FV30C W/WHITE-LED W/PC	6-88-W51PC-5110	OPTION
8	AVC CAMERA CROWN TX1 DCPH/28 FHD DCPH NS30C FV30C W/WHITE-LED W/PC	6-88-N650C-4900	OPTION
9	ANTENNA IPEX4 WLAN WGT W1.1 PCB AL 24G/5G WL1-450MM NS80HC	6-23-7N850-011	
10	ANTENNA IPEX4 WLAN WGT W1.2 PCB AL 24G/5G WL2-450MM NS80HC	6-23-7N850-020	
11	LCD BACK COVER MODULE (MP) N850HC	6-39-N8501-022	
12	WIRE CABLE FOR EDP FHD 300MM (D) 15V SUPN CDRALS COMAUX0300-4F) NES80U	6-43-N85H1-020-2S	
13	.SCREW M2.5x6L K BZ ICT NY	6-35-82125-6RA	
14	.SCREW M2.5x4L KI NI ICT NY	6-35-21125-4R0	
15	FRONT COVER SCREW RUBBER SILICON N850HC	6-47-N8501-040	
16	LCD HINGE R (SGCC+S50C)(MP) N850HC	6-33-N8501-0R2	
17	ANTENNA IPEX4 WLAN WGT W1.1 PCB AL 24G/5G WL1-450MM NS80HC	6-23-7N250-010	
18	MYLAR(7x6x0.15MM,BLACK) FOR P640RF	6-40-00150-760	

Figure A - 5
LCD



Appendix B: Schematic Diagrams

This appendix has circuit diagrams of the *N850HL* notebook's PCB's. The following table indicates where to find the appropriate schematic diagram.

Diagram - Page	Diagram - Page	Diagram - Page
<i>System Block Diagram - Page B - 2</i>	<i>PCH 4/9 - Page B - 23</i>	<i>VCC_Core, VCCGT - Page B - 44</i>
<i>Processor 1/6 - Page B - 3</i>	<i>PCH 5/9 - Page B - 24</i>	<i>I.0DX_VCCSTG/VCCSFR_OC, 3.3VA - Page B - 45</i>
<i>Processor 2/6 - Page B - 4</i>	<i>PCH 6/9 - Page B - 25</i>	<i>VCCSA - Page B - 46</i>
<i>Processor 3/6 - Page B - 5</i>	<i>PCH 7/9 - Page B - 26</i>	<i>AC_In, Charger - Page B - 47</i>
<i>Processor 4/6 - Page B - 6</i>	<i>PCH 8/9 - Page B - 27</i>	<i>NVVDD - Page B - 48</i>
<i>Processor 5/6 - Page B - 7</i>	<i>PCH 9/9 - Page B - 28</i>	<i>FBVDDQ - Page B - 49</i>
<i>Processor 6/6 - Page B - 8</i>	<i>M.2 3G Card - Page B - 29</i>	<i>PEX_VDD/3V3 - Page B - 50</i>
<i>DDR4 CHA SO-DIMM - Page B - 9</i>	<i>M.2 WLAN+BT, SSD - Page B - 30</i>	<i>Audio Board - Page B - 51</i>
<i>DDR4 CHB SO-DIMM - Page B - 10</i>	<i>ASM 1142 & 2142 - Page B - 31</i>	<i>Power Switch Board - Page B - 52</i>
<i>VGA PCI-E Interface - Page B - 11</i>	<i>ASM Power - Page B - 32</i>	<i>Hall Sensor Board - Page B - 53</i>
<i>VGA Frame Buffer Interface - Page B - 12</i>	<i>USB, Charger - Page B - 33</i>	<i>Click Board - Page B - 54</i>
<i>VGA Frame Buffer A - Page B - 13</i>	<i>Card Reader / LAN RTL8411B - Page B - 34</i>	<i>LED Board - Page B - 55</i>
<i>VGA Frame Buffer A - Page B - 14</i>	<i>HDD, Click TP, Audio, Hall Con. - Page B - 35</i>	<i>Power Sequence - Page B - 56</i>
<i>VGA I/O - Page B - 15</i>	<i>LED, CCD, TPM, Power SW Con. - Page B - 36</i>	
<i>VGA NVVDD Coupling - Page B - 16</i>	<i>Audio Codec ALC269 VC2 - Page B - 37</i>	
<i>Panel, Inverter - Page B - 17</i>	<i>KBC-ITE IT8587 - Page B - 38</i>	
<i>CRT - Page B - 18</i>	<i>5V, 5VS, 3.3V, 3.3VS, 3.3VA - Page B - 39</i>	
<i>HDMI - Page B - 19</i>	<i>VDD1.0, VCCIO - Page B - 40</i>	
<i>PCH 1/9 - Page B - 20</i>	<i>VDD3, VDD5 - Page B - 41</i>	
<i>PCH 2/9 - Page B - 21</i>	<i>DDR 1.2V/0.6VS, 2.5V - Page B - 42</i>	
<i>PCH 3/9 - Page B - 22</i>	<i>VCore, VCCGT Output Stage - Page B - 43</i>	

Table B - 1
**SCHEMATIC
DIAGRAMS**



Version Note

The schematic diagrams in this chapter are based upon version 6-7P-N85L6-001. If your mainboard (or other boards) are a later version, please check with the Service Center for updated diagrams (if required).

System Block Diagram

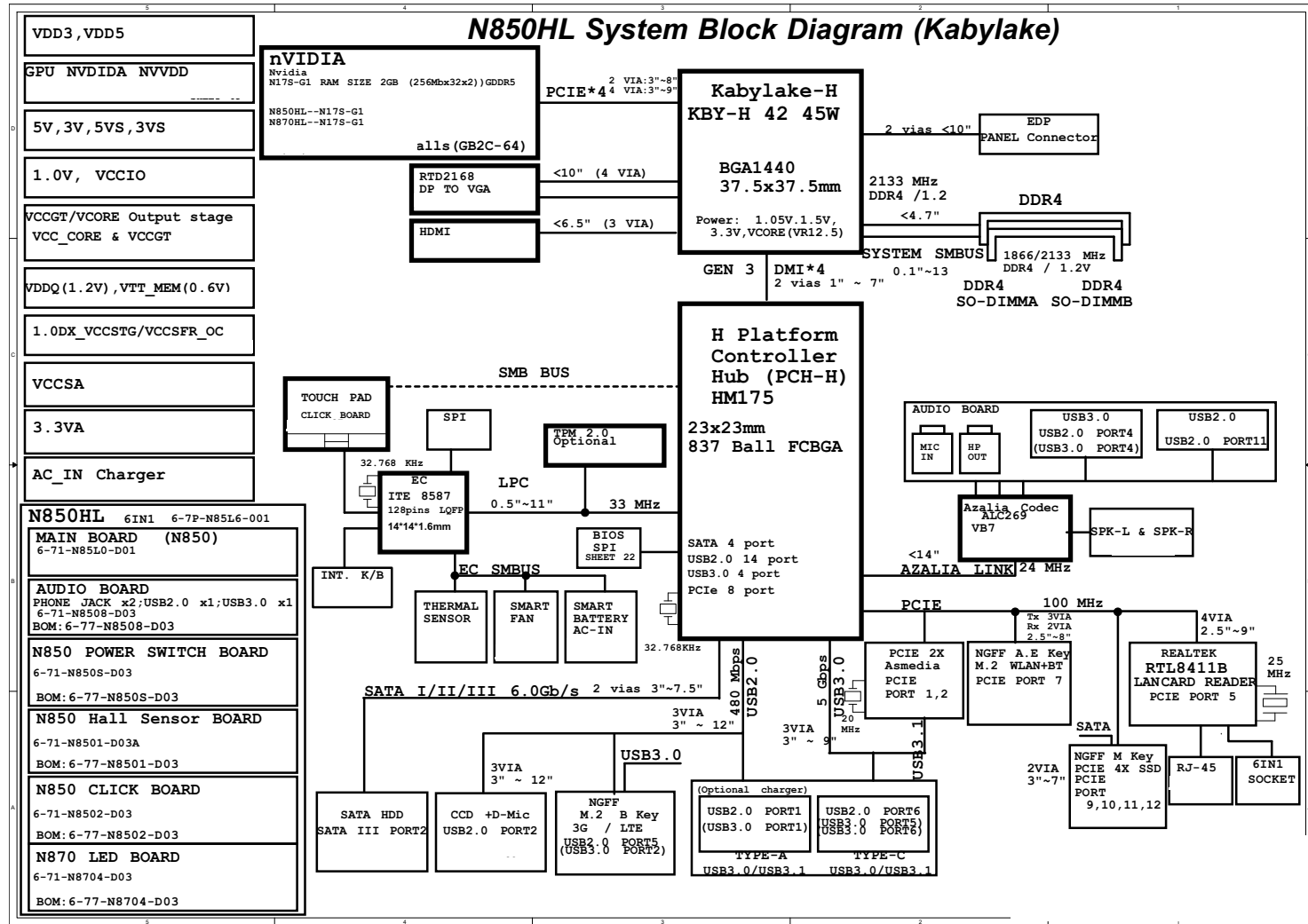

Sheet 1 of 55
 System Block
 Diagram

Processor 2/6

Sheet 3 of 55
Processor 2/6

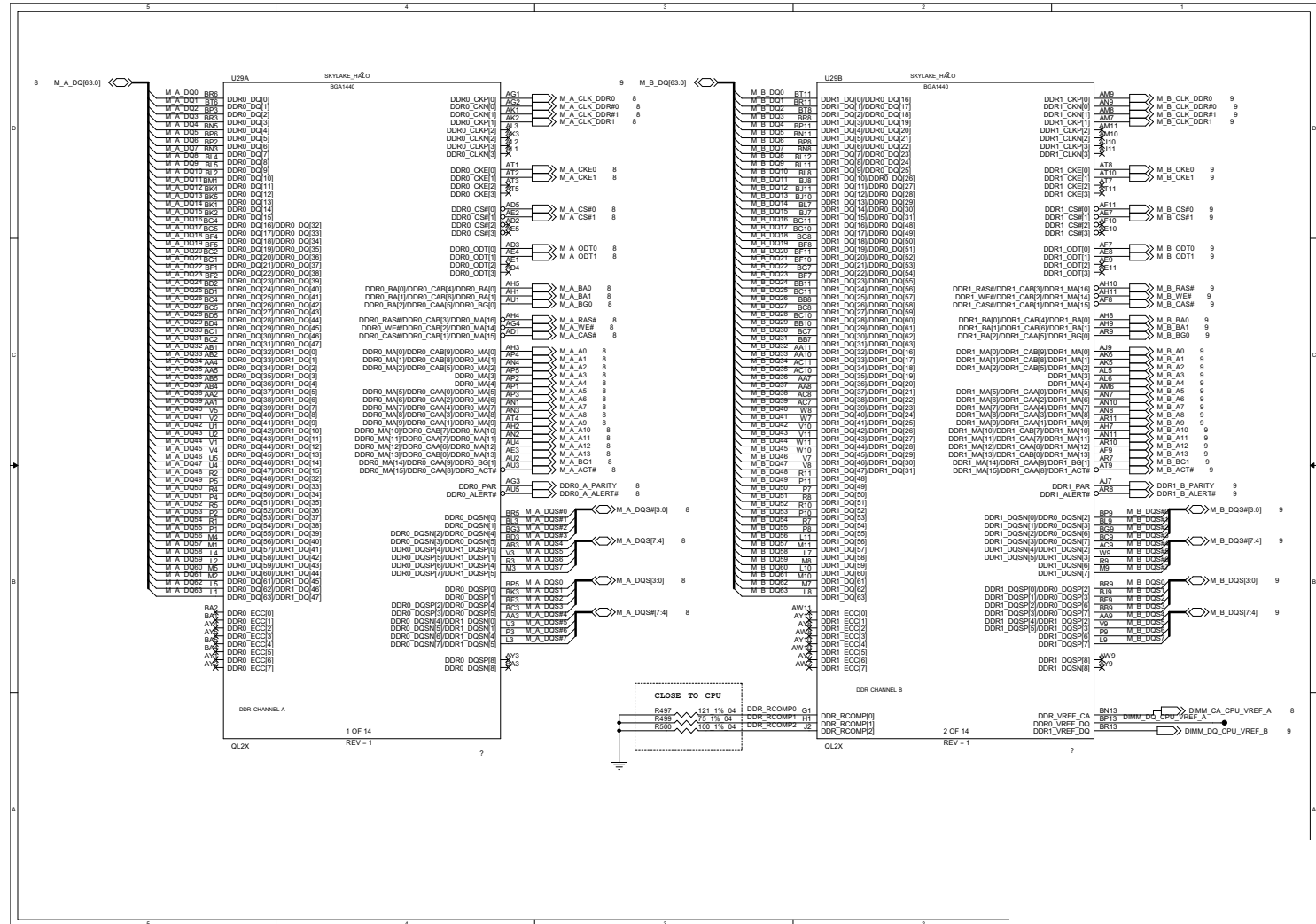

Processor 3/6

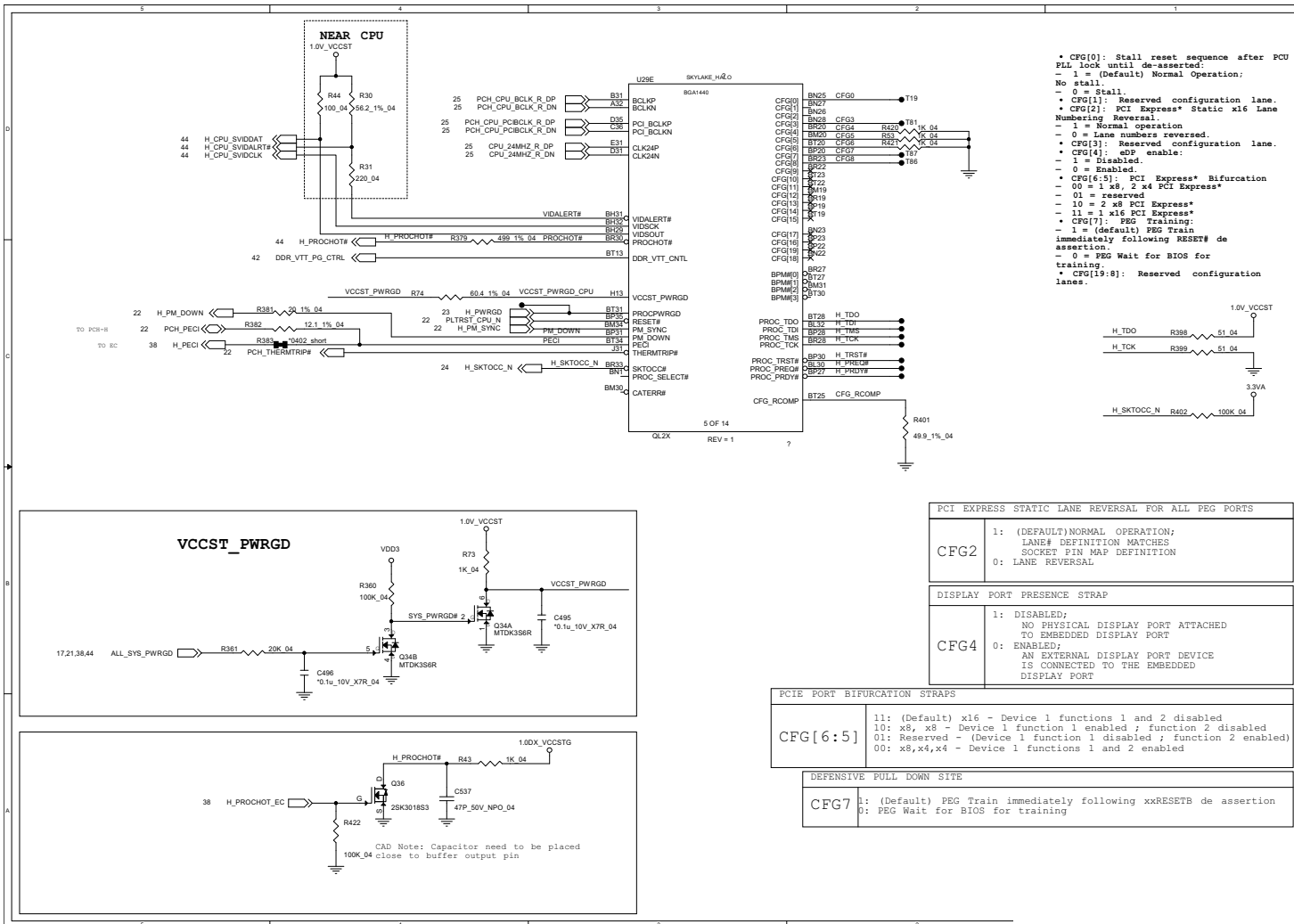

Sheet 4 of 55
Processor 3/6

B.Schematic Diagrams

Processor 5/6

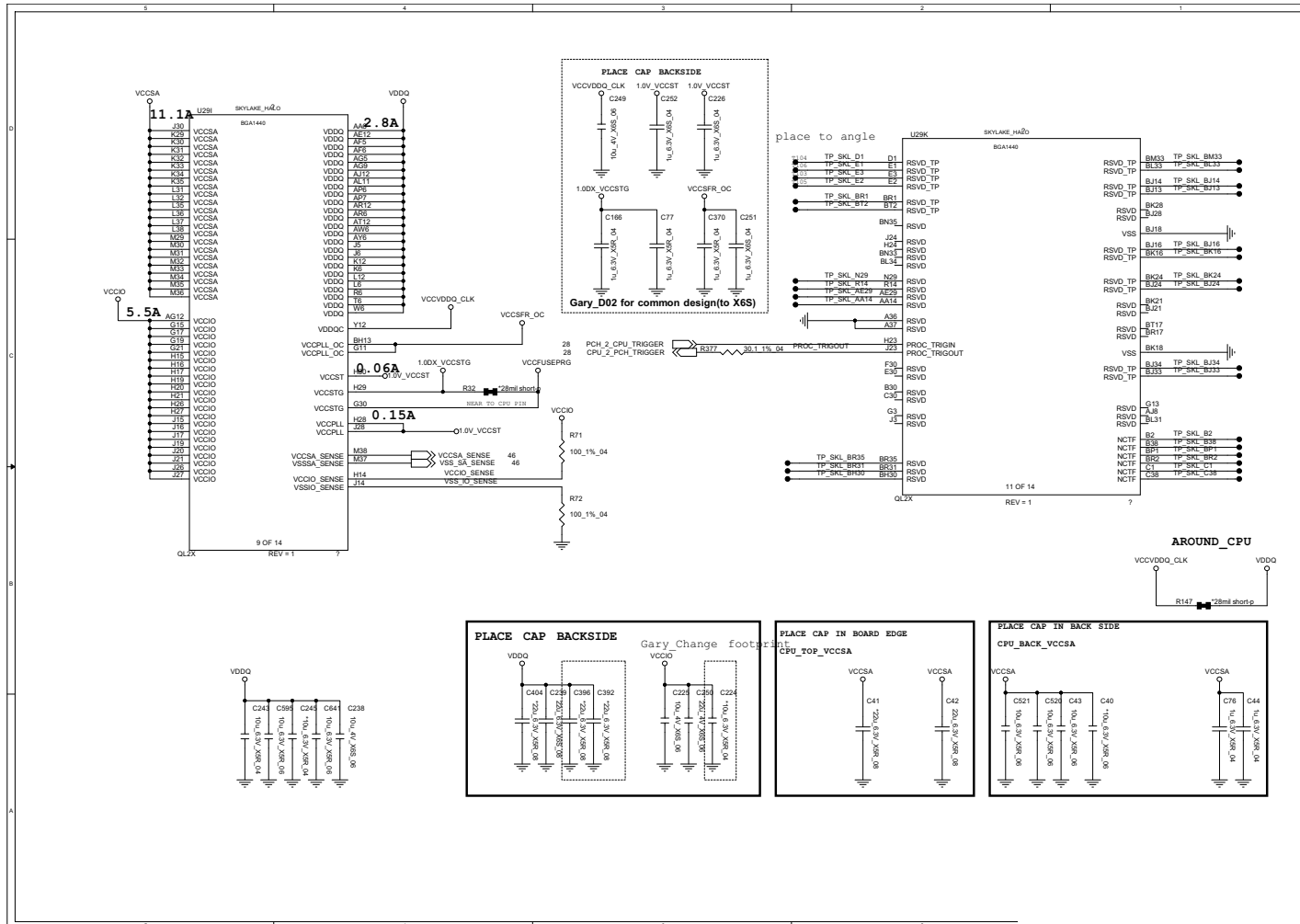

B.Schematic Diagrams

Sheet 6 of 55
Processor 5/6

Schematic Diagrams

Processor 6/6

Sheet 7 of 55
Processor 6/6

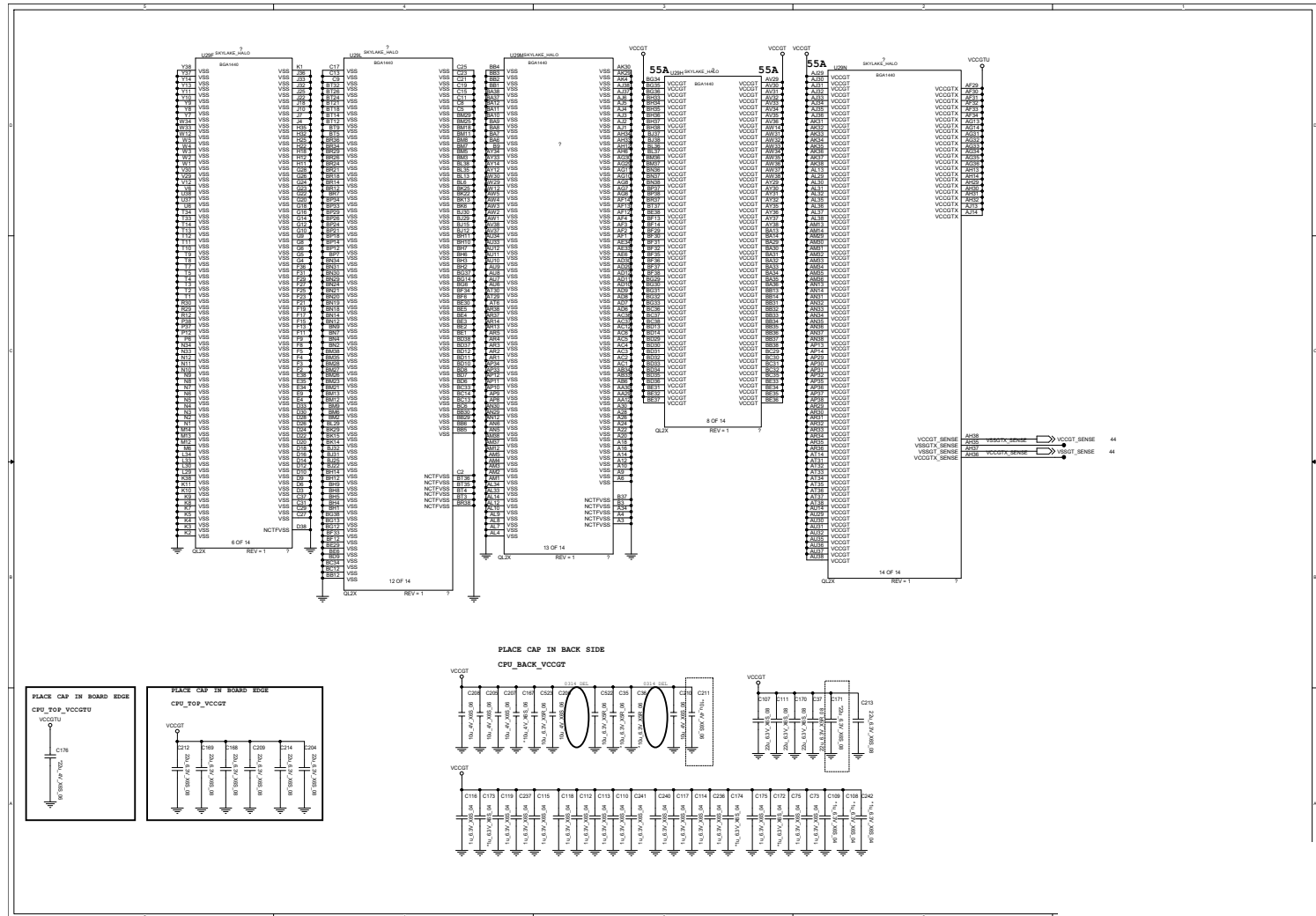

VGA PCI-E Interface

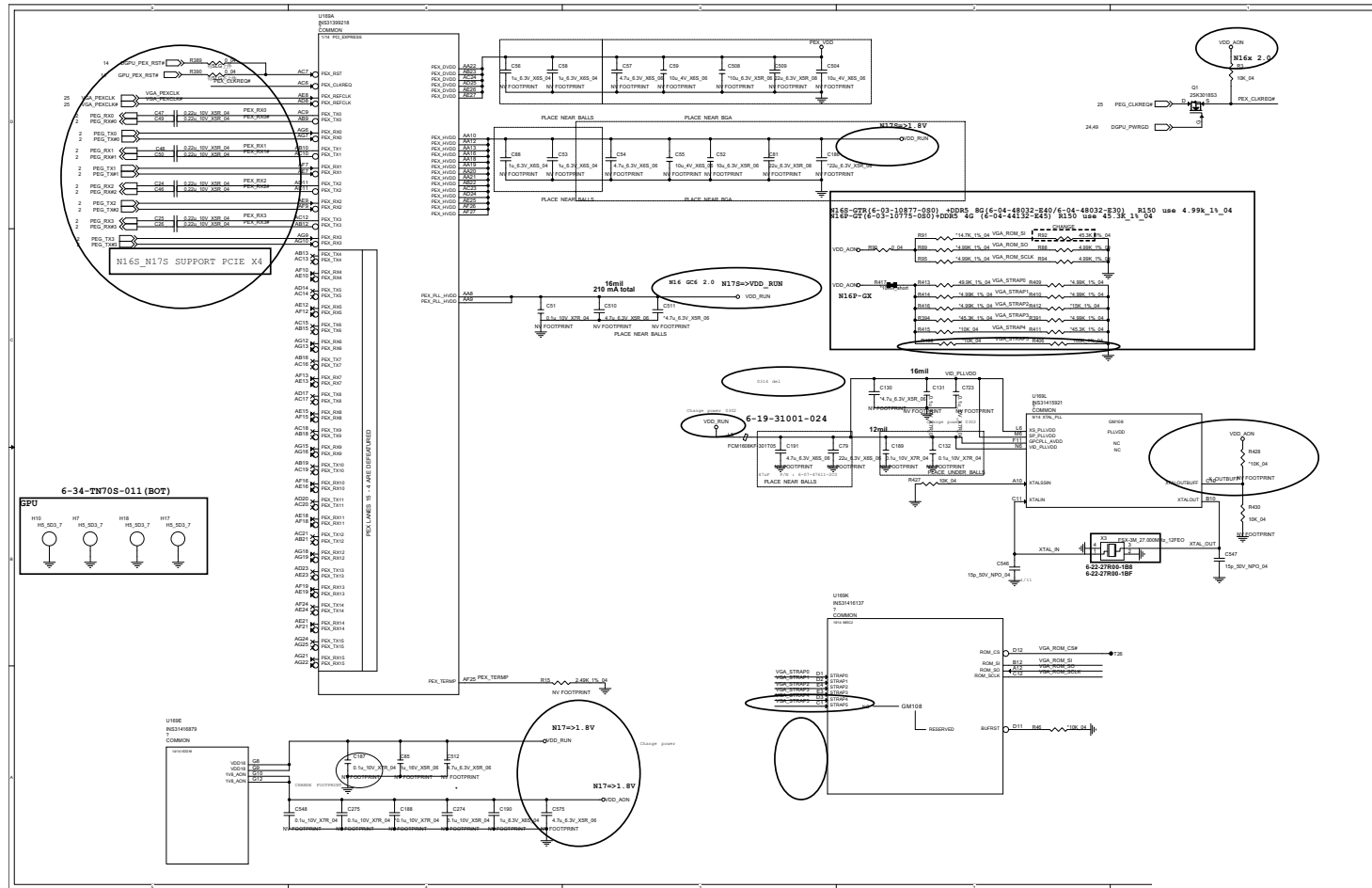

Sheet 10 of 55
VGA PCI-E
Interface

VGA Frame Buffer Interface

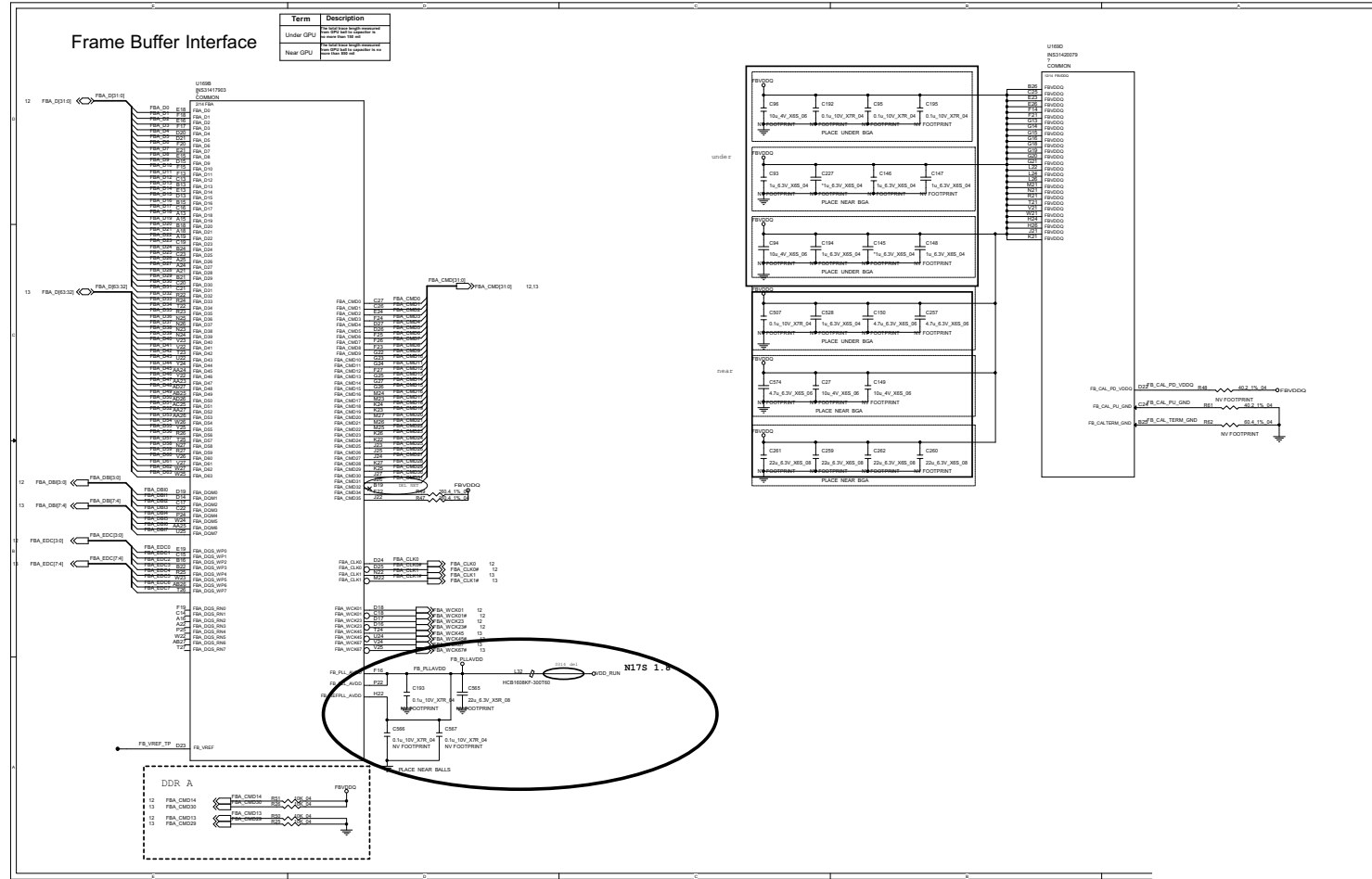

Sheet 11 of 55
VGA Frame Buffer Interface

VGA Frame Buffer A

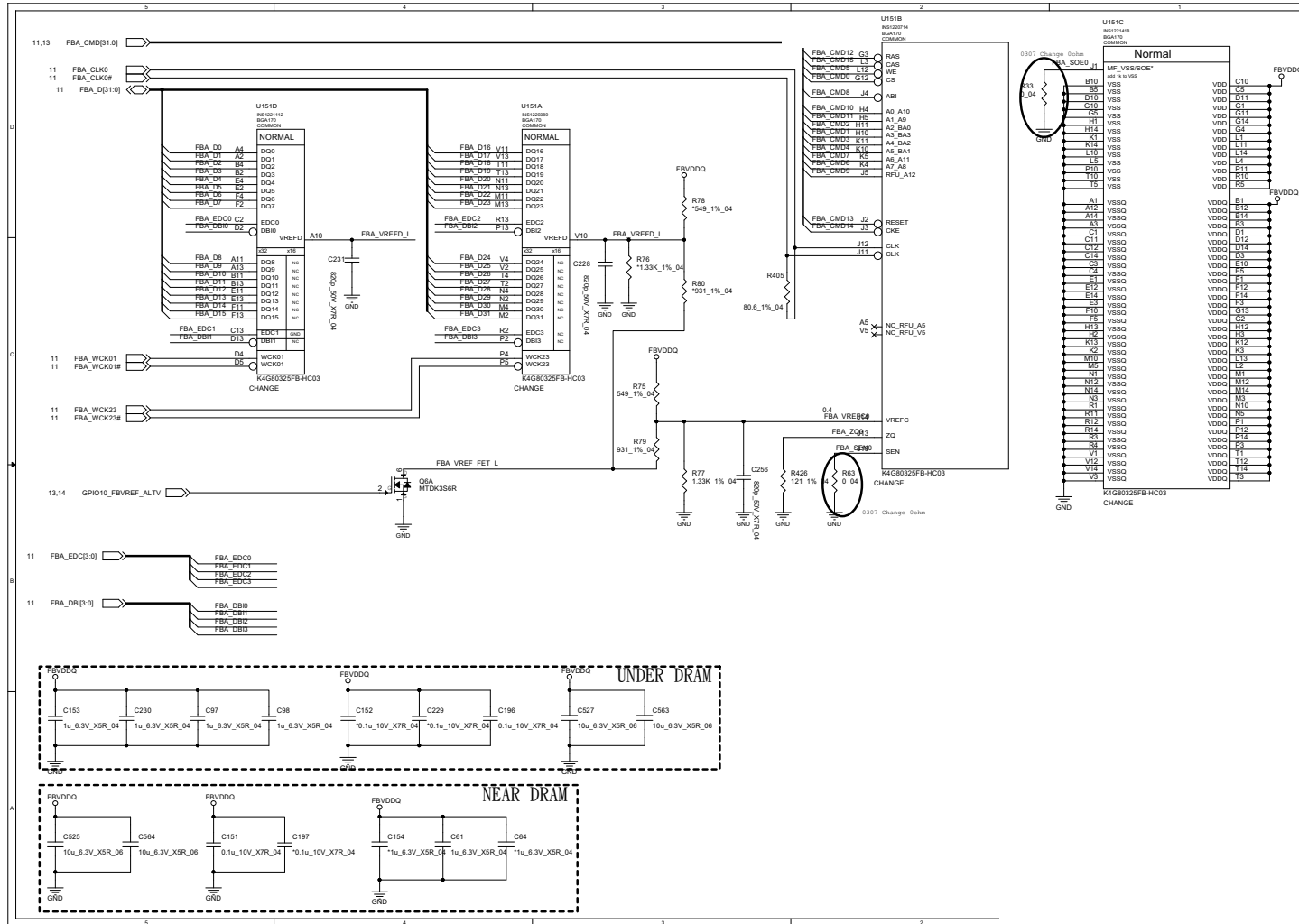

Sheet 12 of 55
VGA Frame Buffer
A

B.Schematic Diagrams

VGA Frame Buffer A

Sheet 13 of 55
VGA Frame Buffer
A

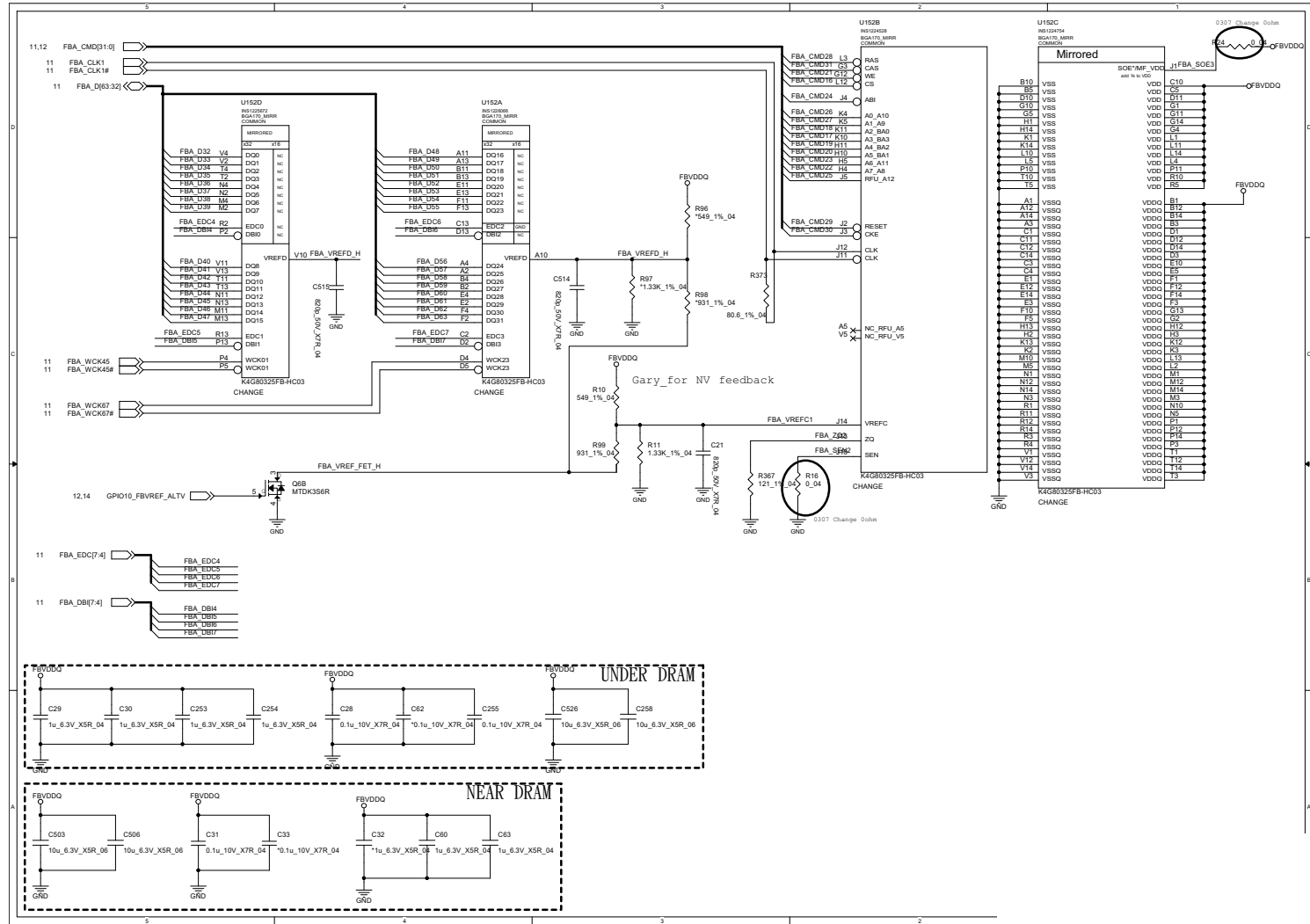

VGA I/O

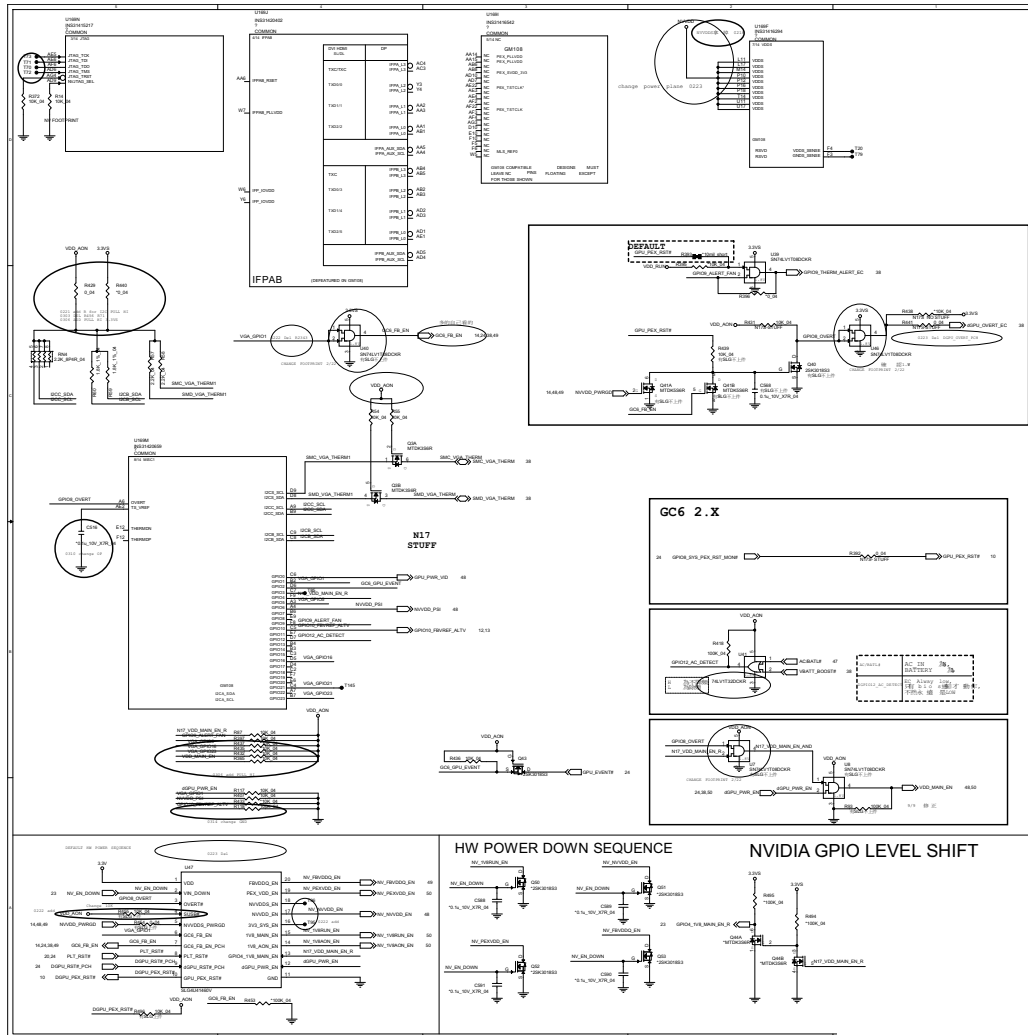

Sheet 14 of 55
VGA I/O

VGA NVVDD Coupling

Sheet 15 of 55
VGA NVVDD
Coupling

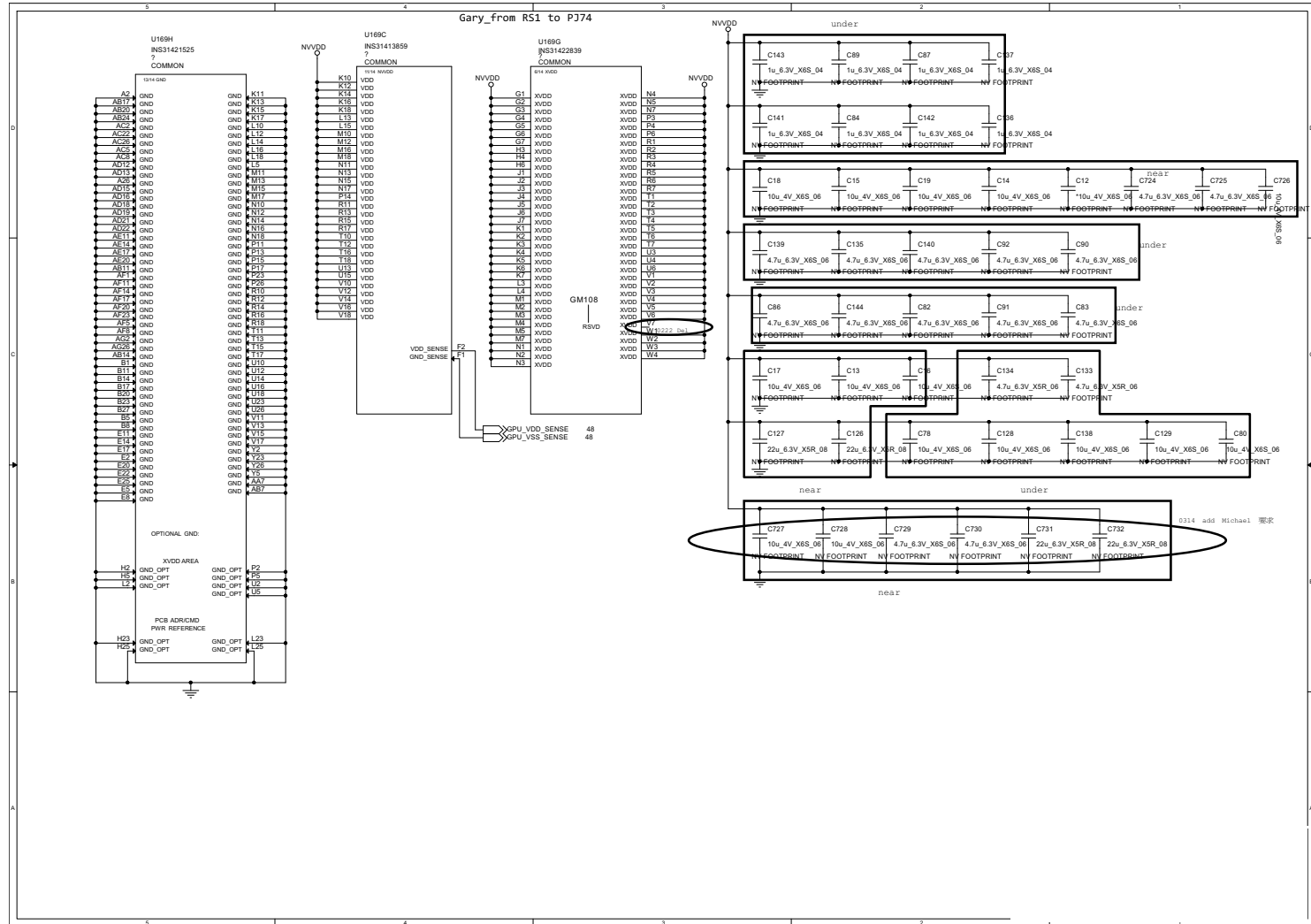

Panel, Inverter

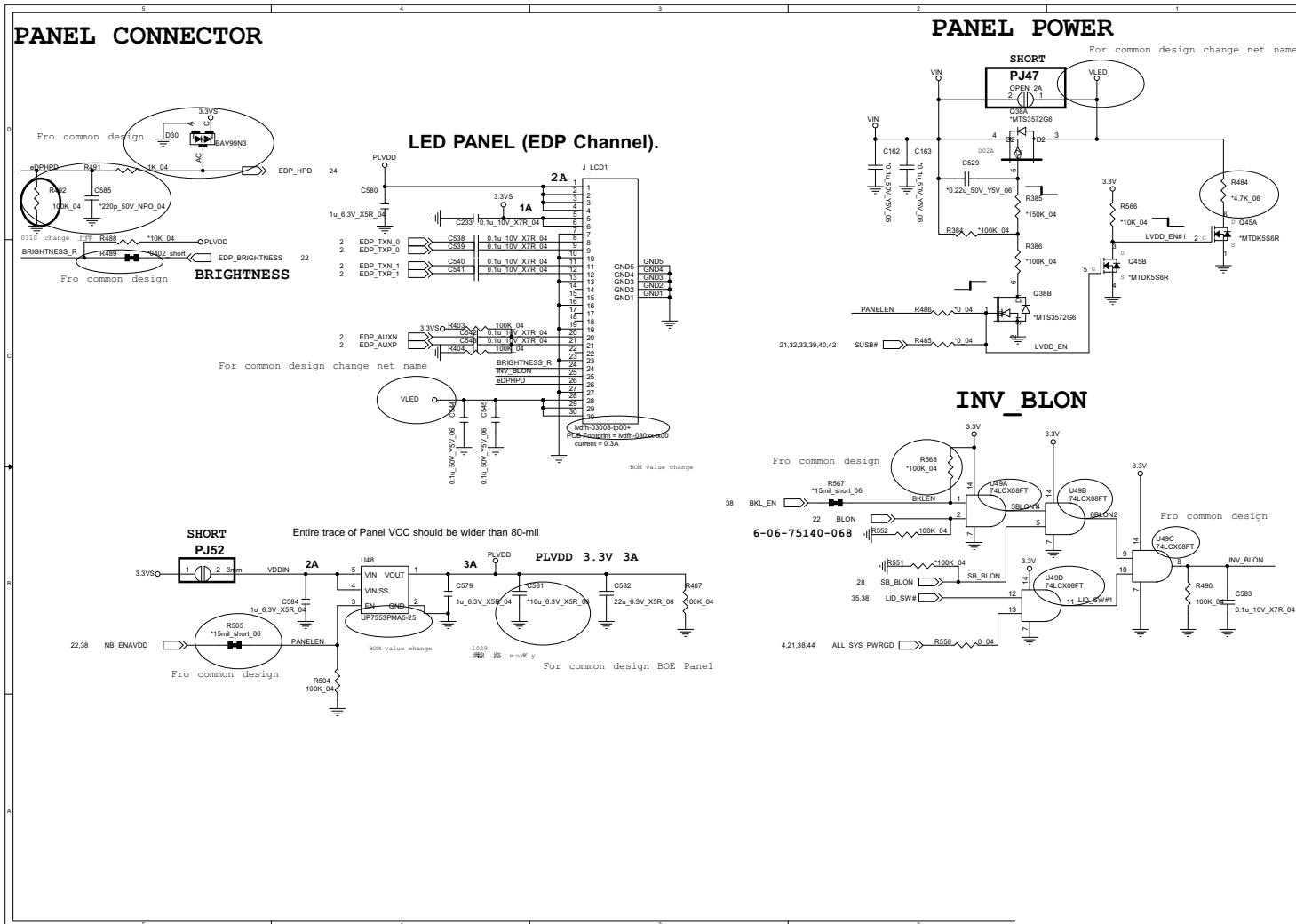

Sheet 16 of 55
Panel, Inverter

B.Schematic Diagrams

PCH 2/9

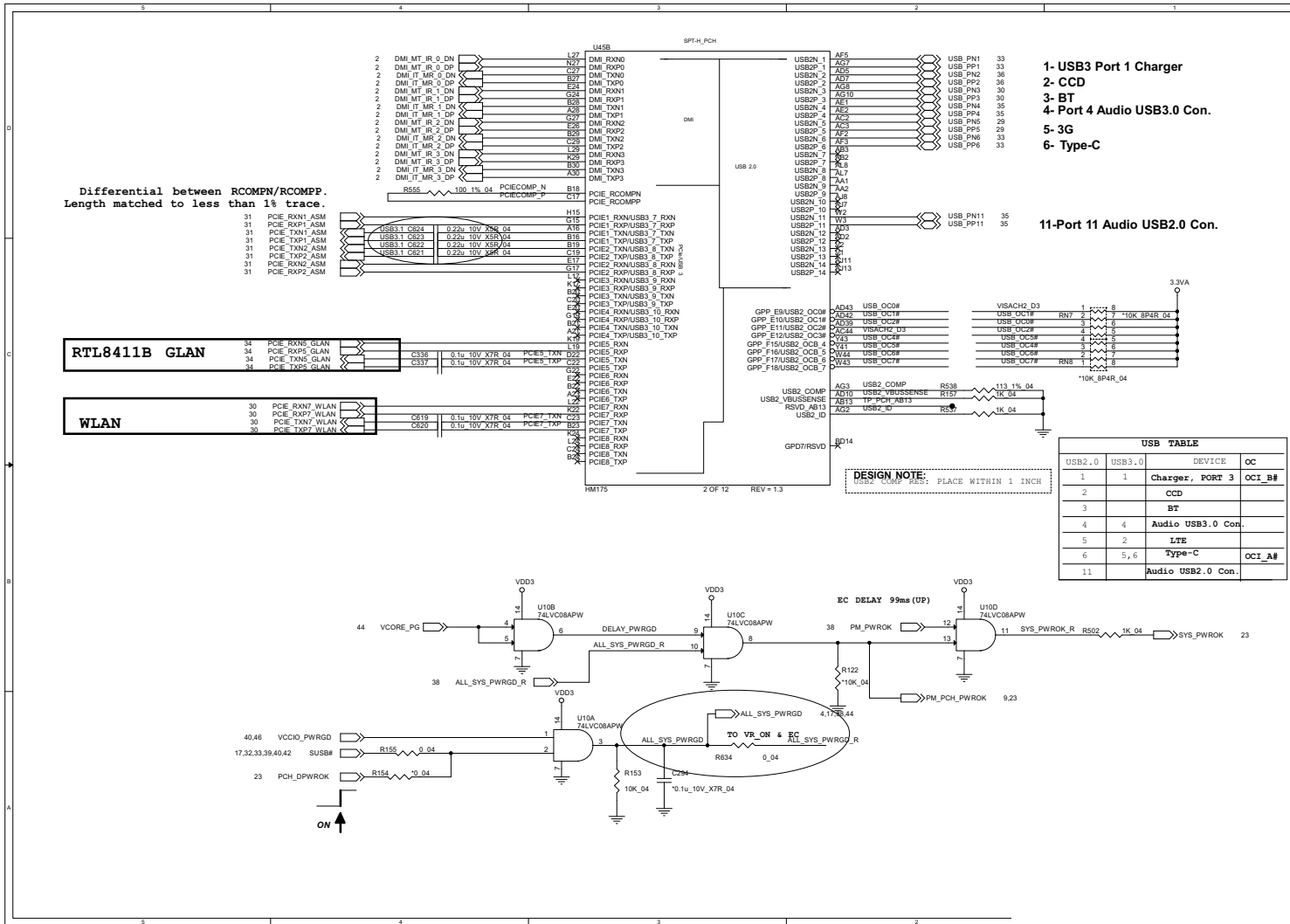

Sheet 20 of 55
PCH 2/9

B.Schematic Diagrams

PCH 3/9

Sheet 21 of 55
PCH 3/9

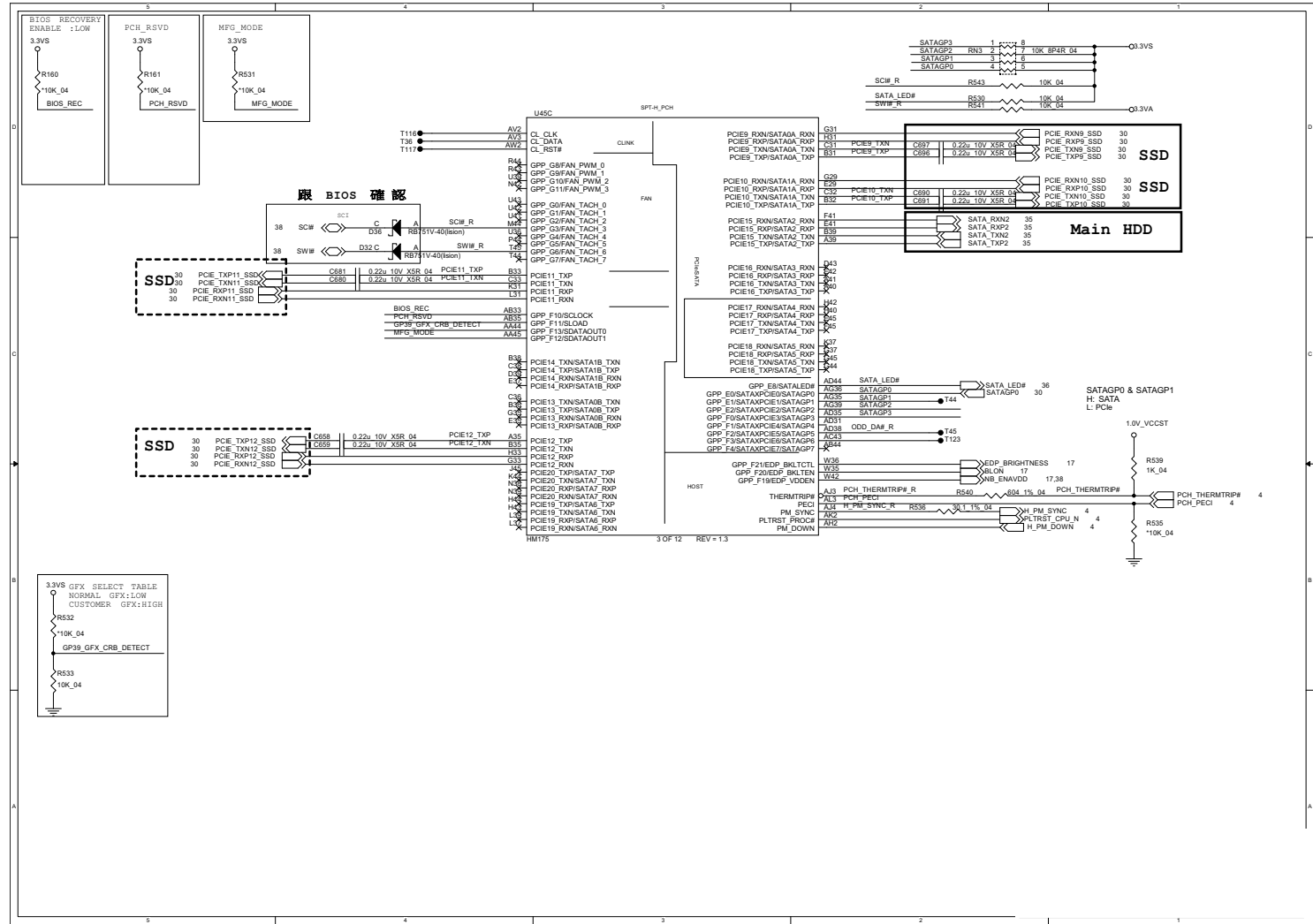

PCH 4/9

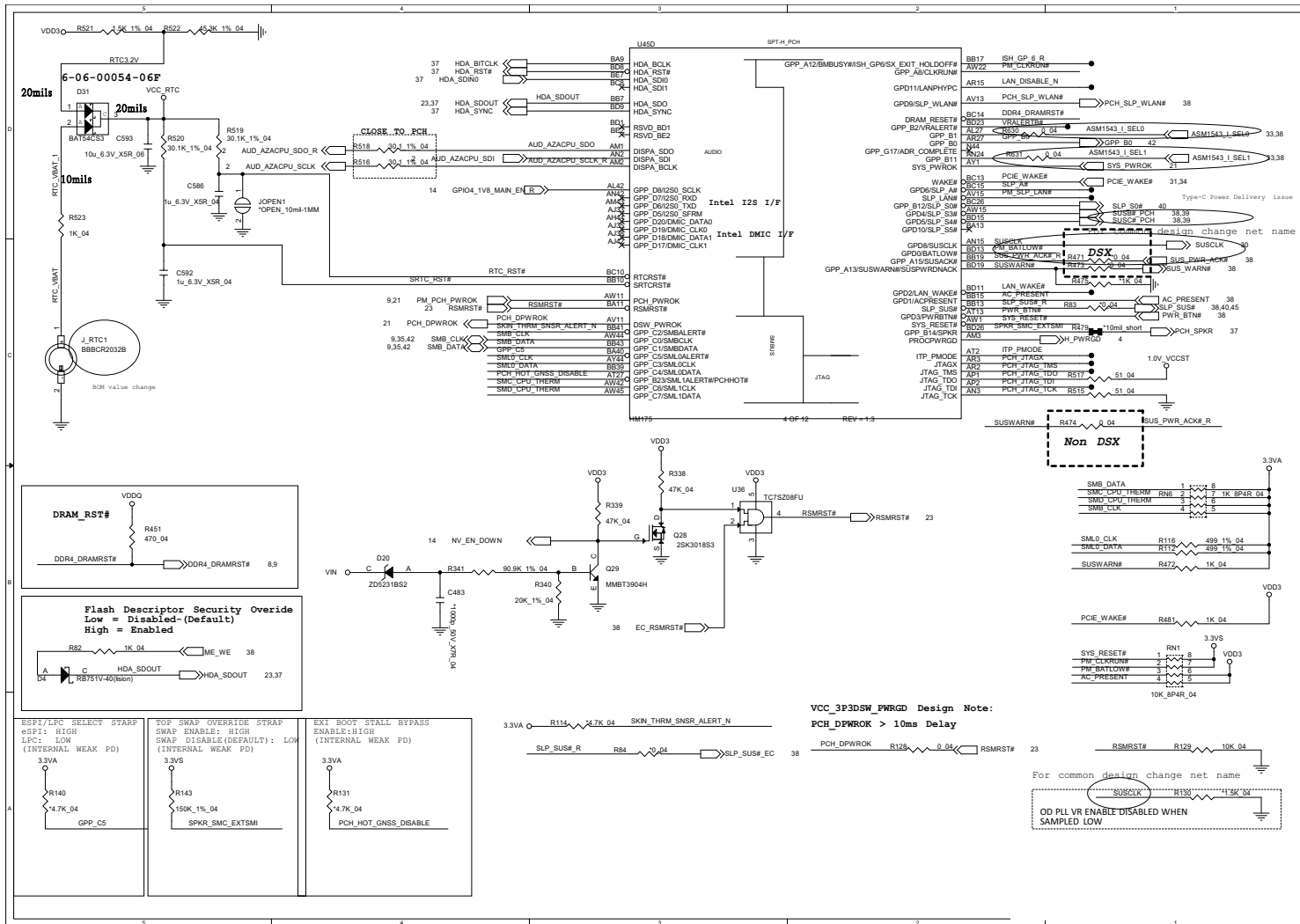

Sheet 22 of 55
PCH 4/9

B.Schematic Diagrams

PCH 5/9

Sheet 23 of 55
PCH 5/9

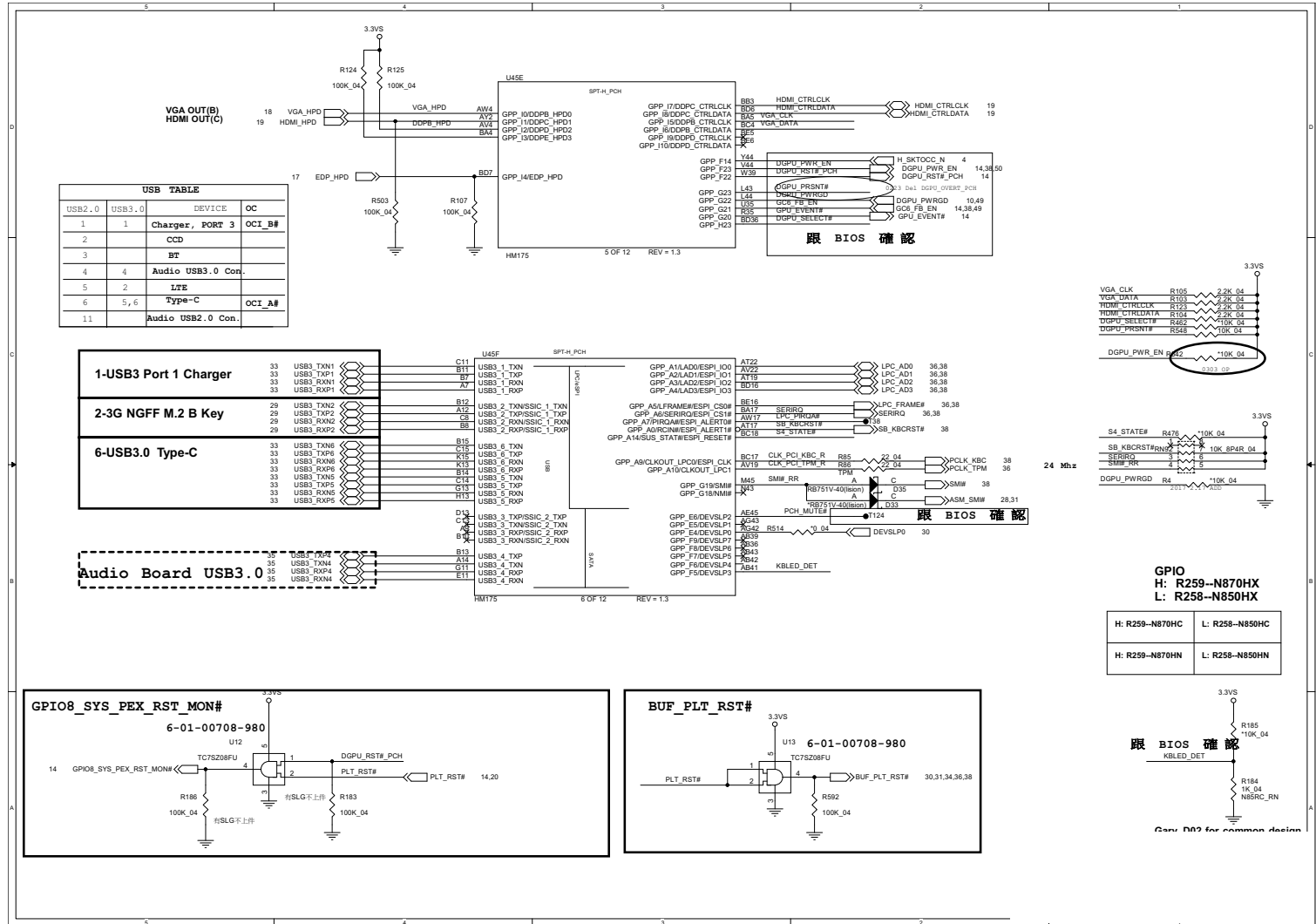

Schematic Diagrams

PCH 7/9

Sheet 25 of 55
PCH 7/9

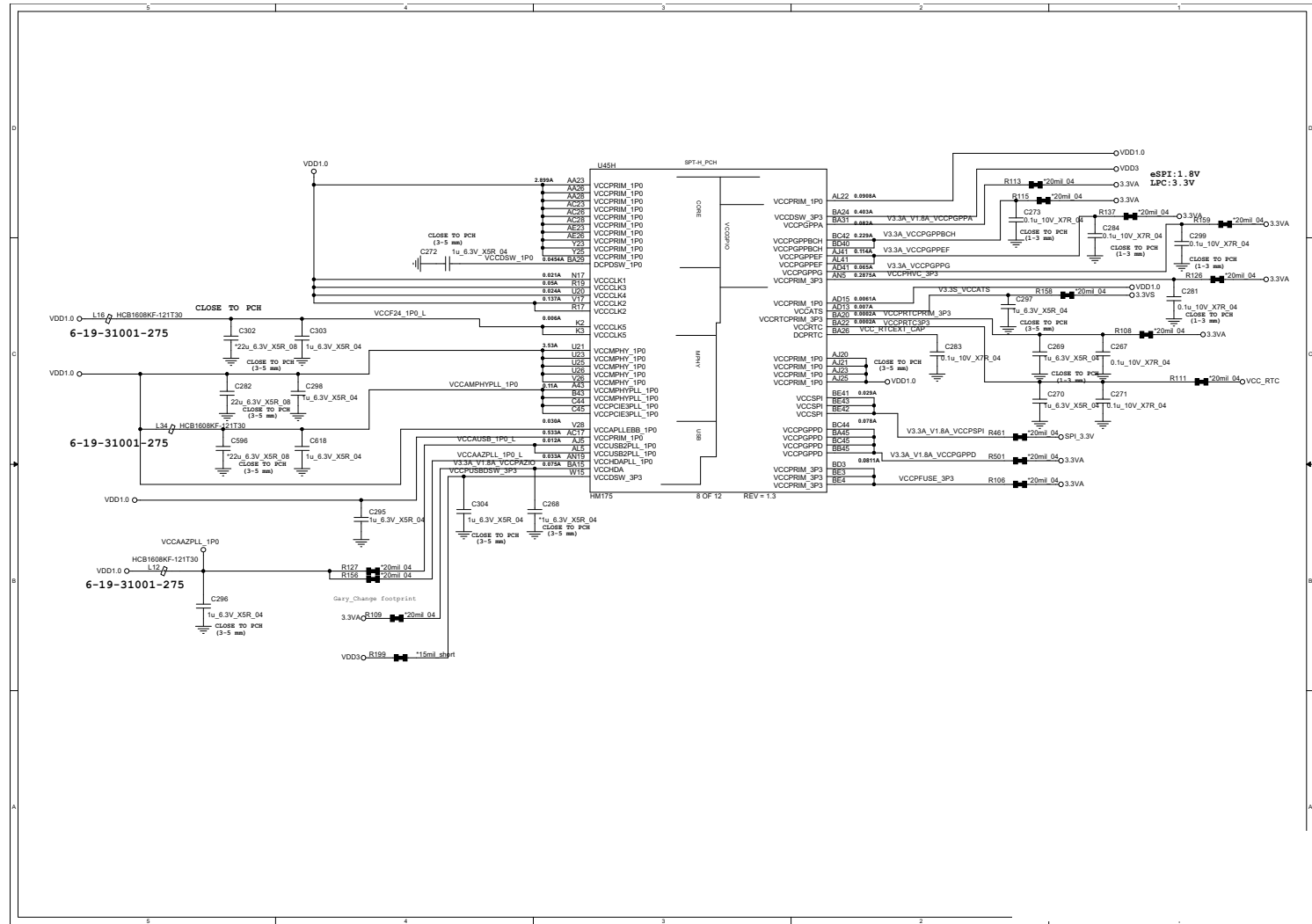

M.2 WLAN+BT, SSD

Sheet 29 of 55
M.2 WLAN+BT,
SSD

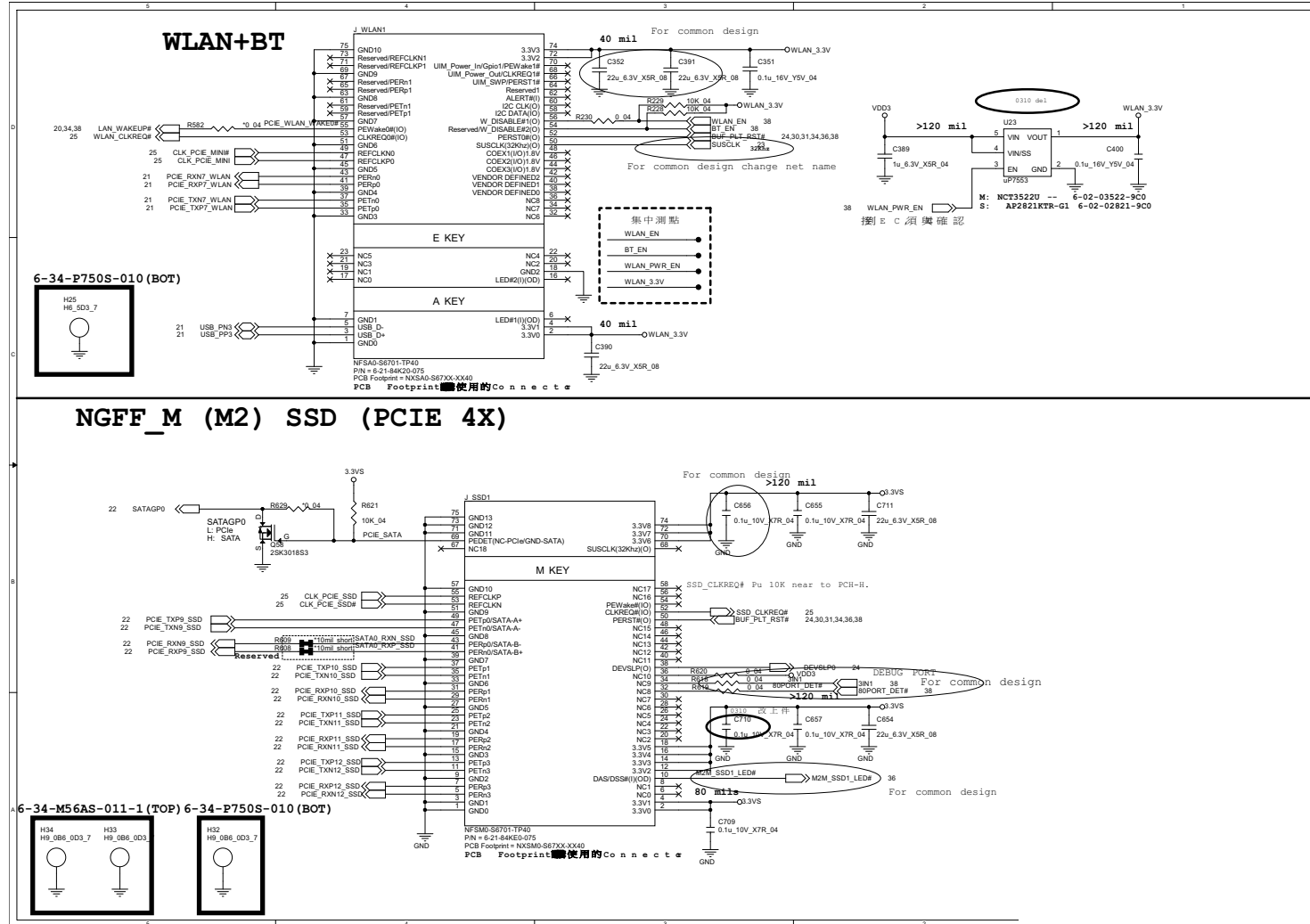

ASM Power

Sheet 31 of 55
ASM Power

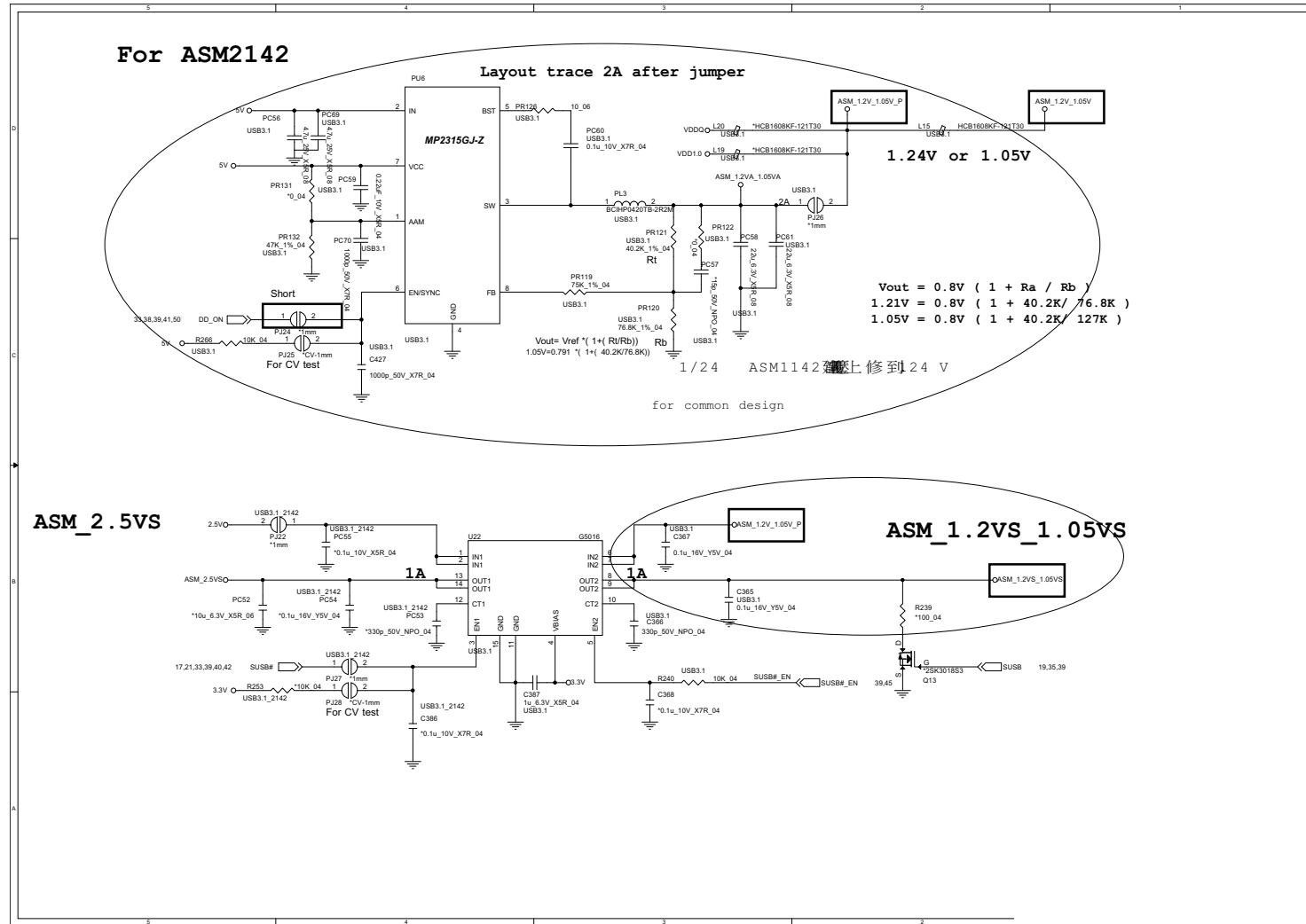

USB, Charger

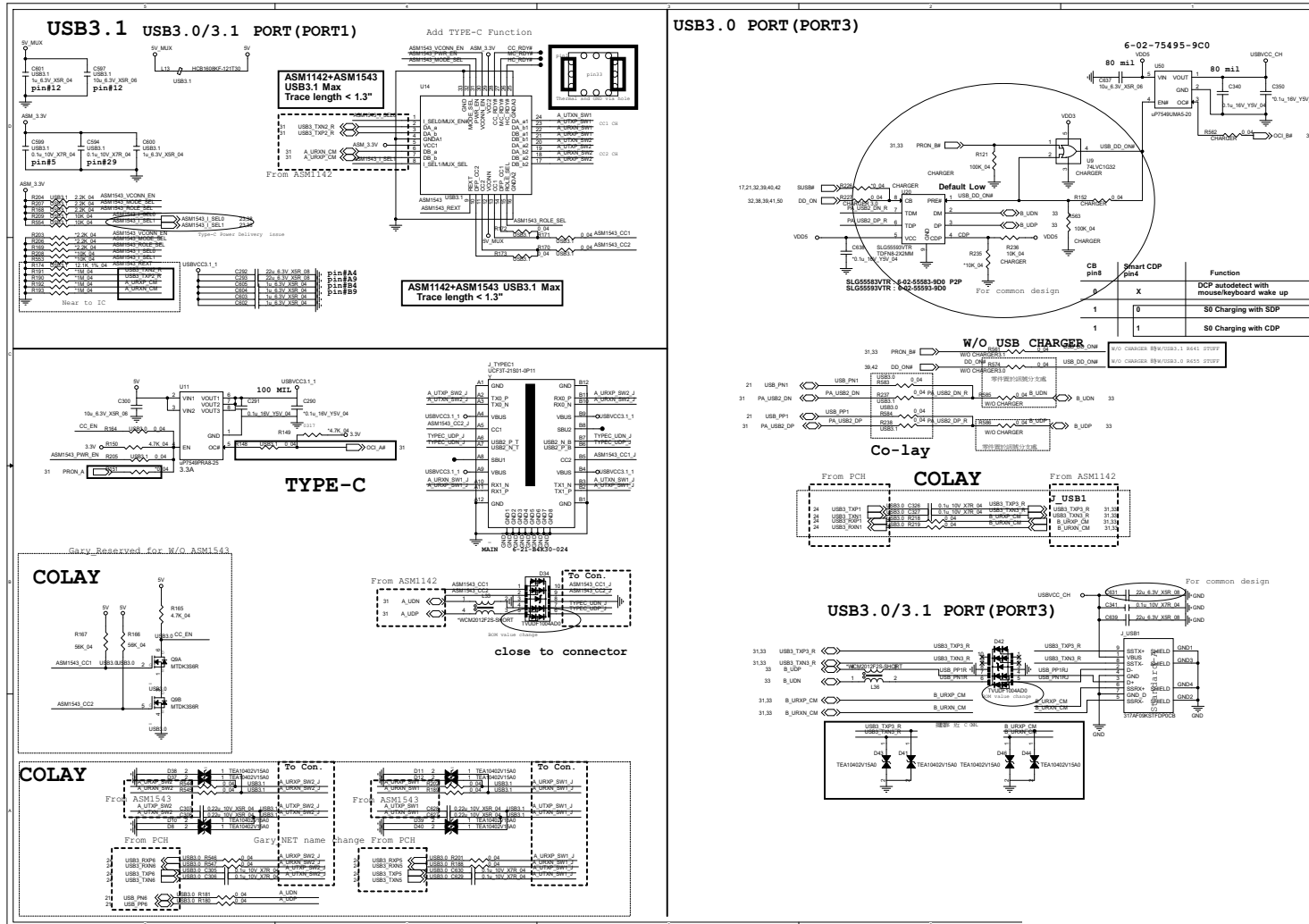

Sheet 32 of 55
USB, Charger

B.Schematic Diagrams

HDD, Click TP, Audio, Hall Con.

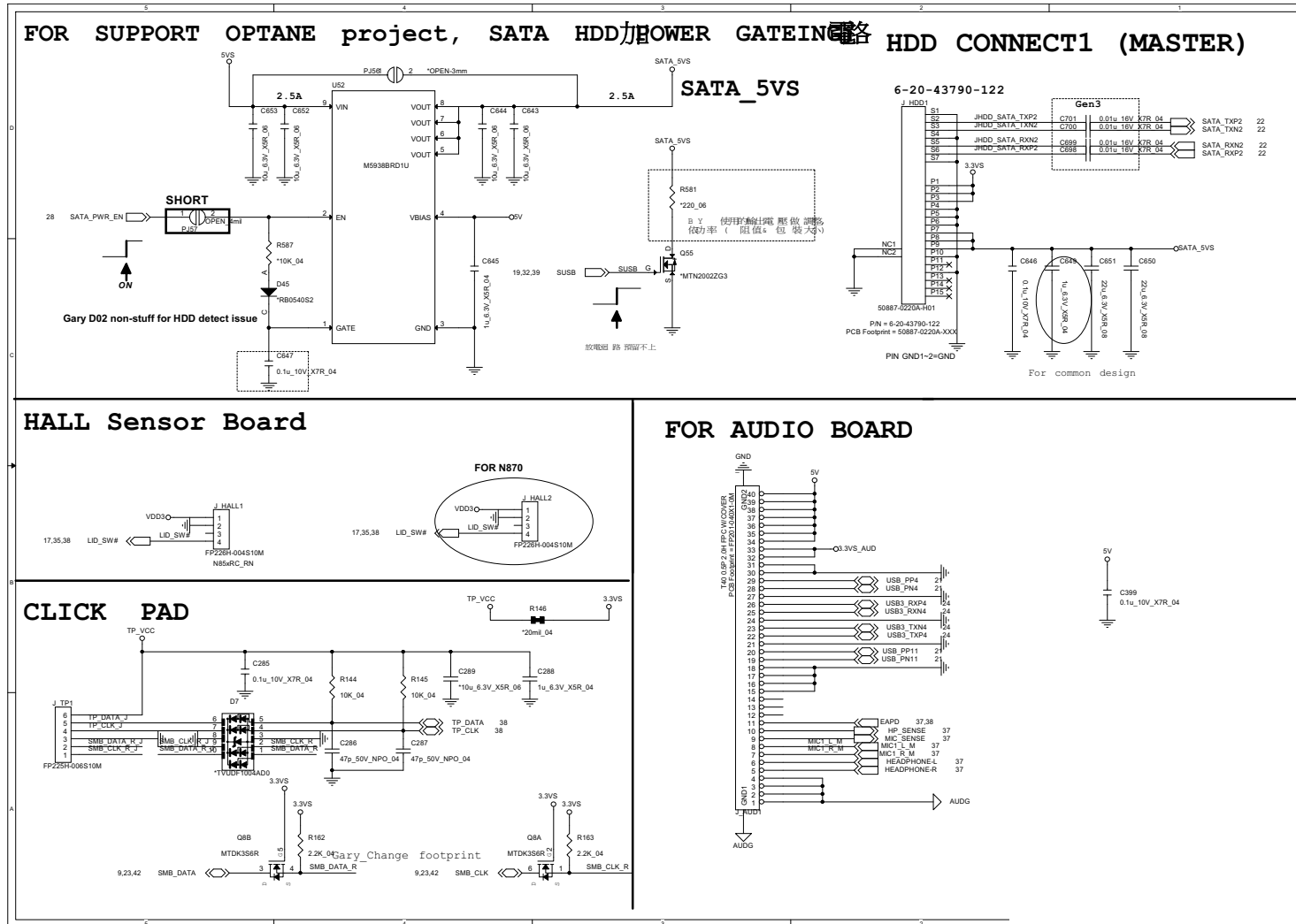

Sheet 34 of 55
 HDD, Click TP,
 Audio, Hall Con.

B.Schematic Diagrams

LED, CCD, TPM, Power SW Con.

Sheet 35 of 55
LED, CCD, TPM,
Power SW Con.

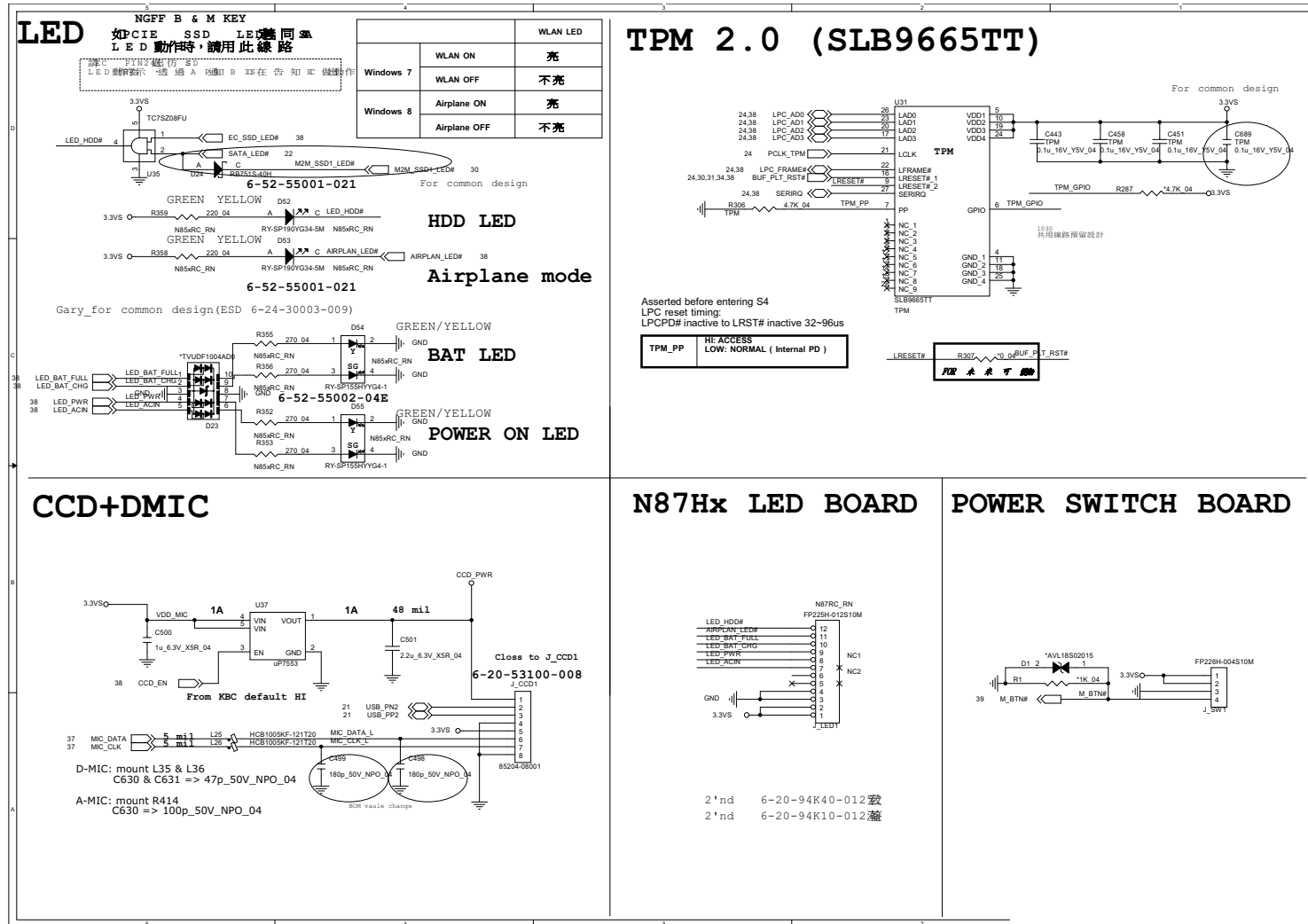

KBC-ITE IT8587

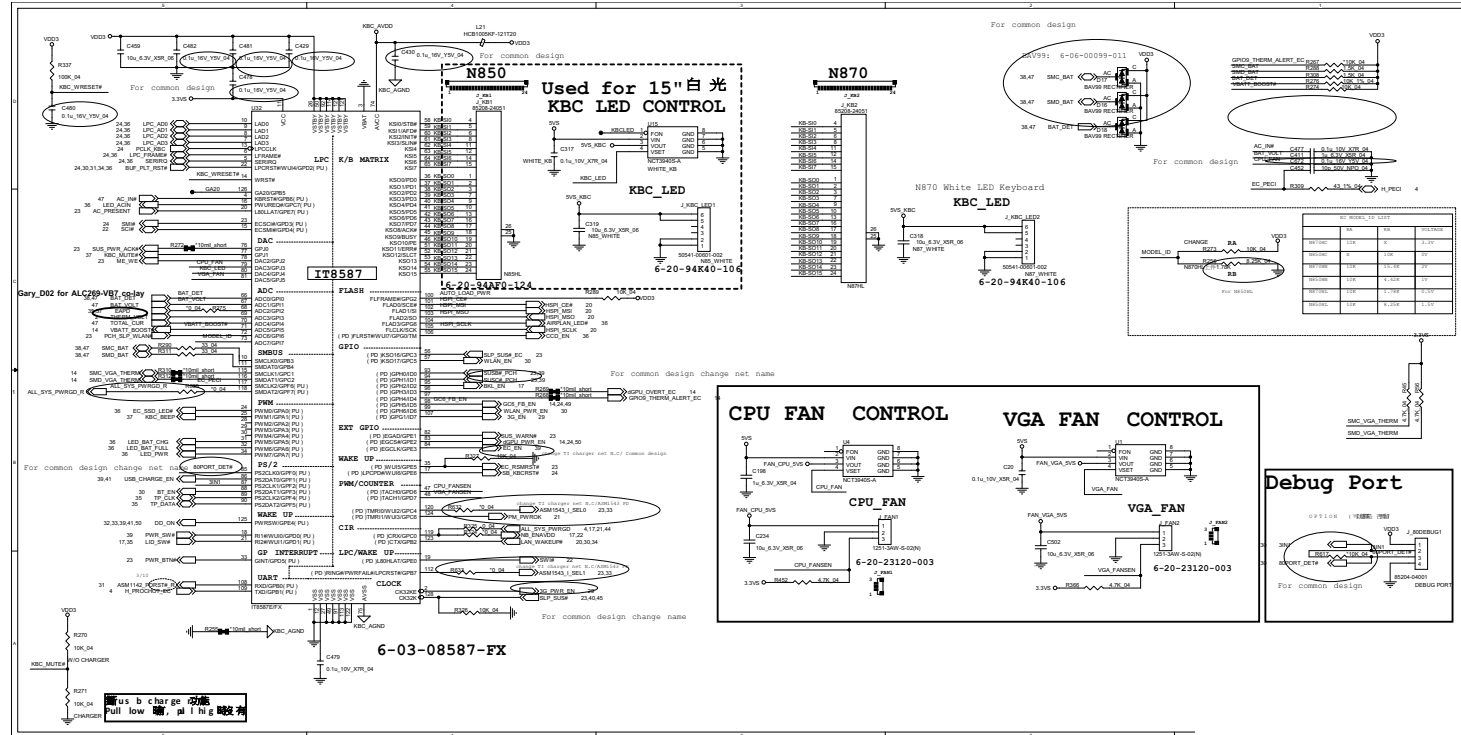

Sheet 37 of 55
KBC-ITE IT8587

B.Schematic Diagrams

5V, 5VS, 3.3V, 3.3VS, 3.3VA

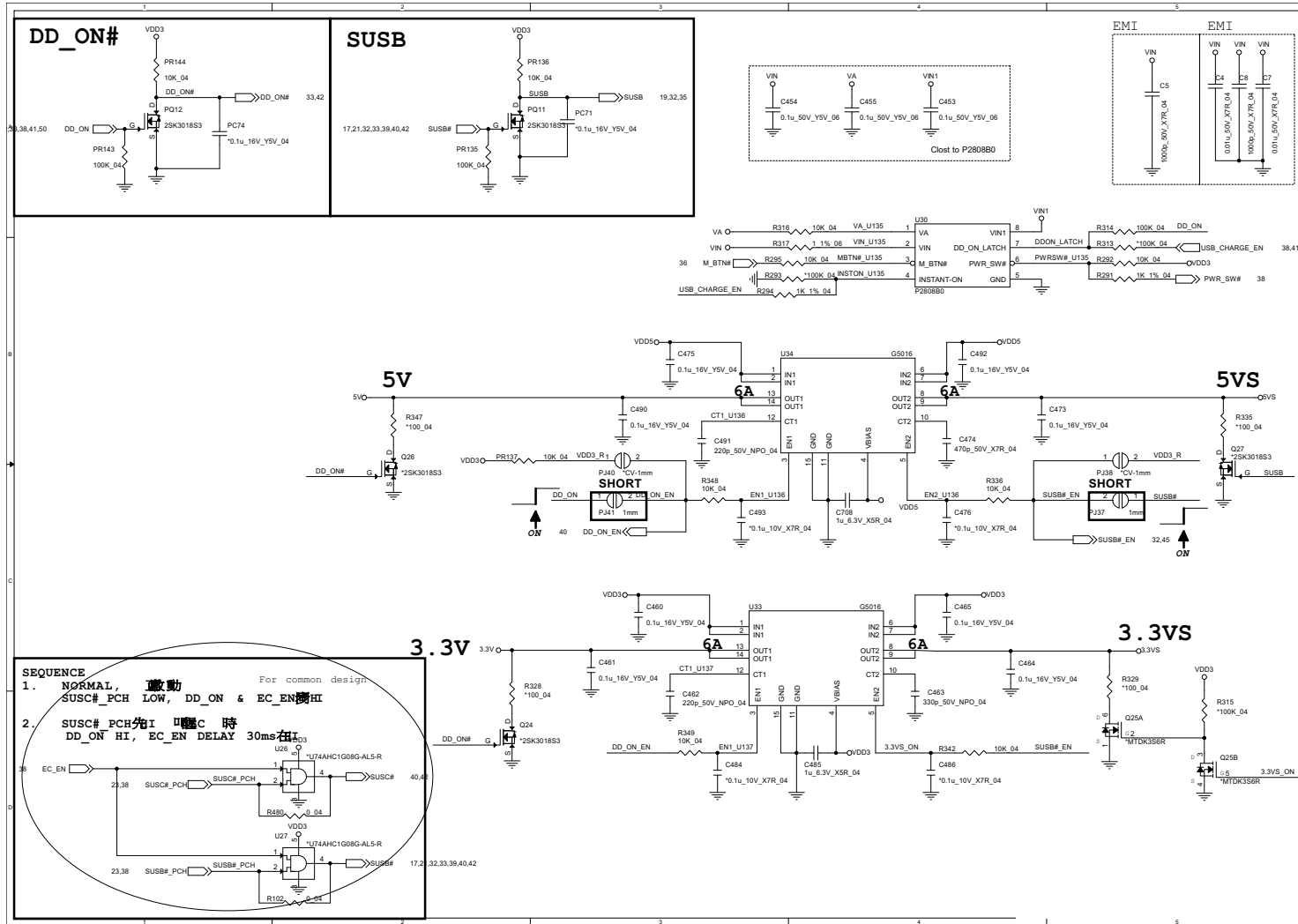

Sheet 38 of 55
5V, 5VS, 3.3V,
3.3VS, 3.3VA

Schematic Diagrams

VDD1.0, VCCIO

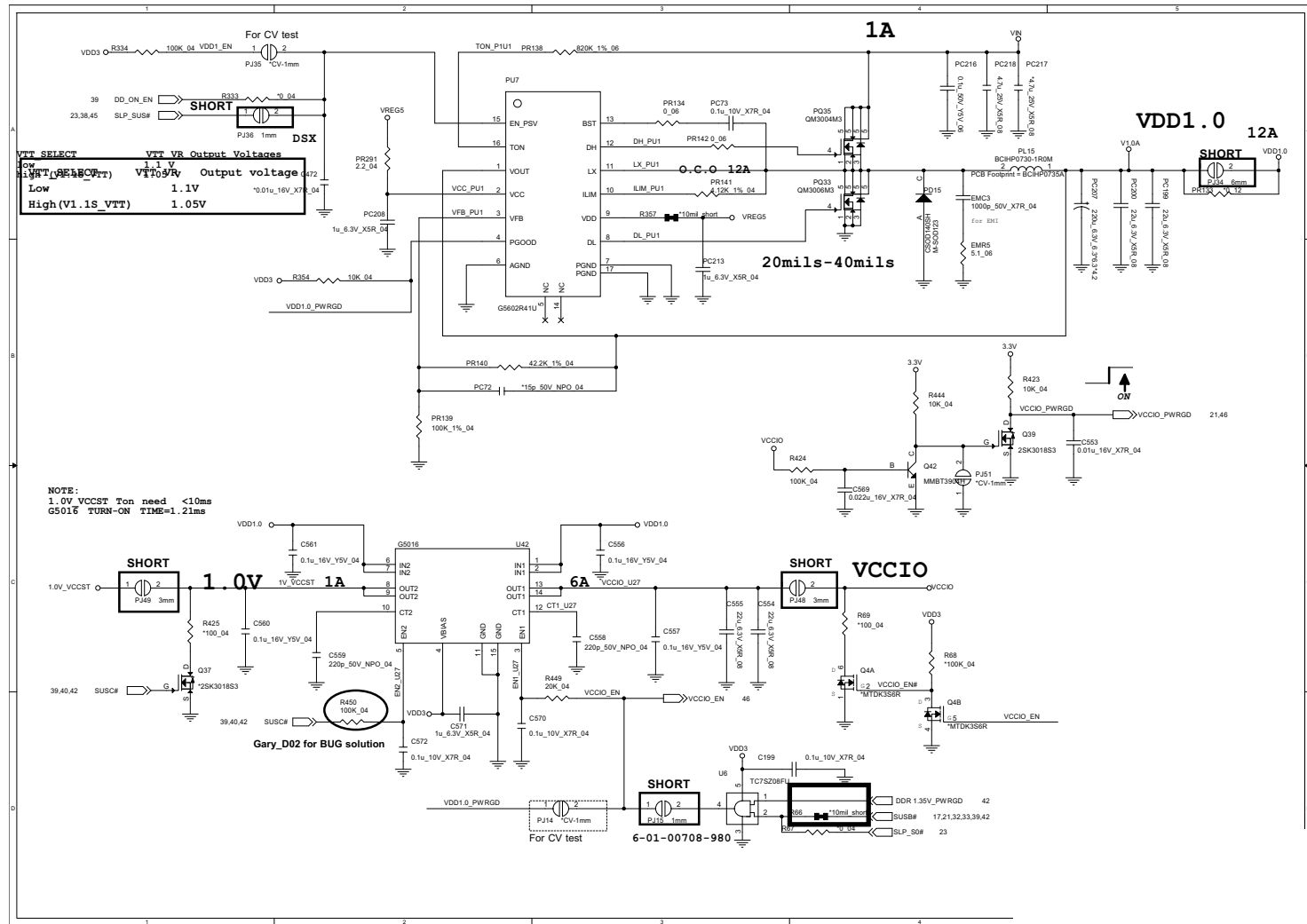

Sheet 39 of 55
 VDD1.0V, VCCIO

B.Schematic Diagrams

VDD3, VDD5

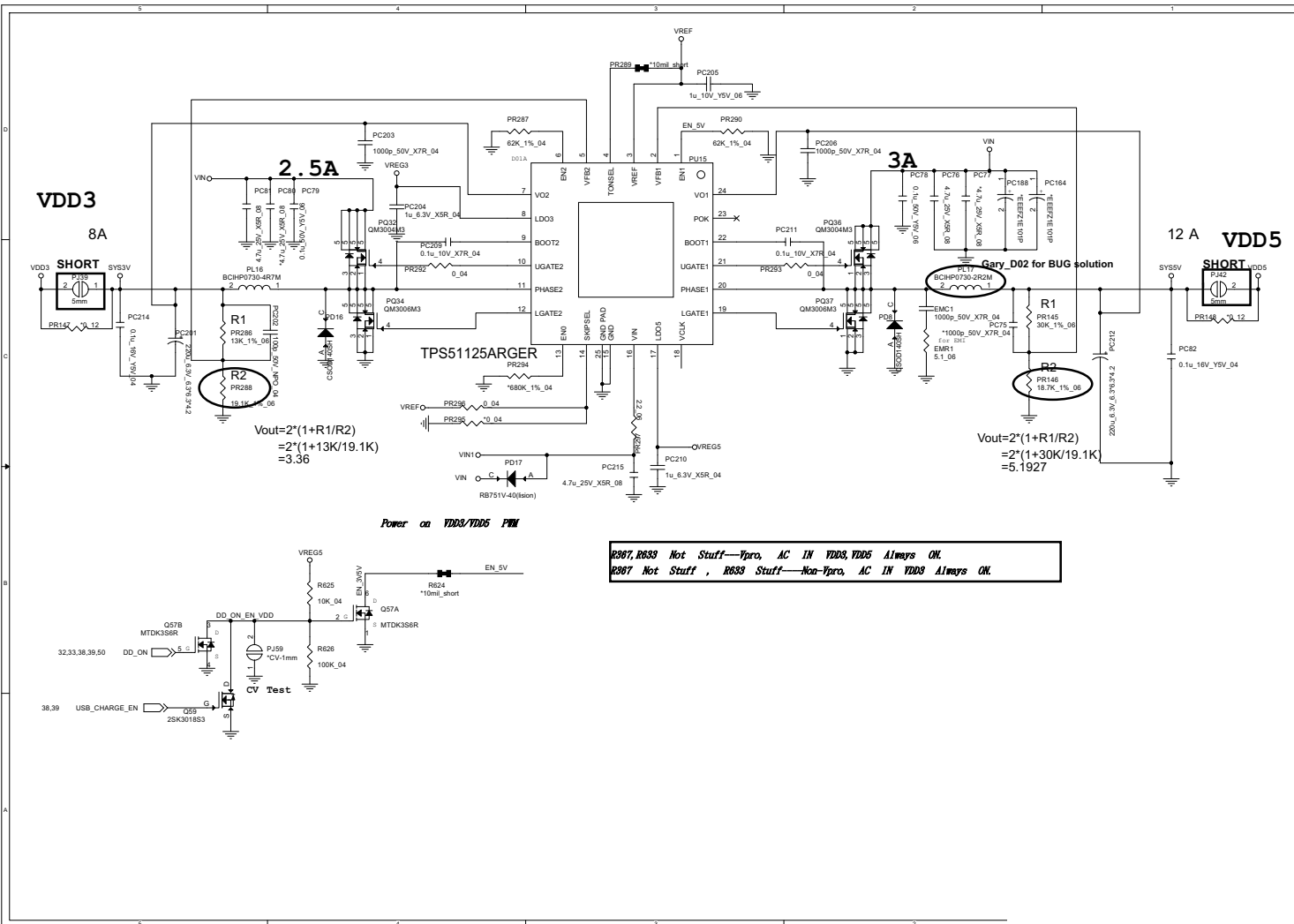

Sheet 40 of 55
VDD3, VDD5

Schematic Diagrams

DDR 1.2V/0.6VS, 2.5V

Sheet 41 of 55
DDR 1.2V/0.6VS,
2.5V

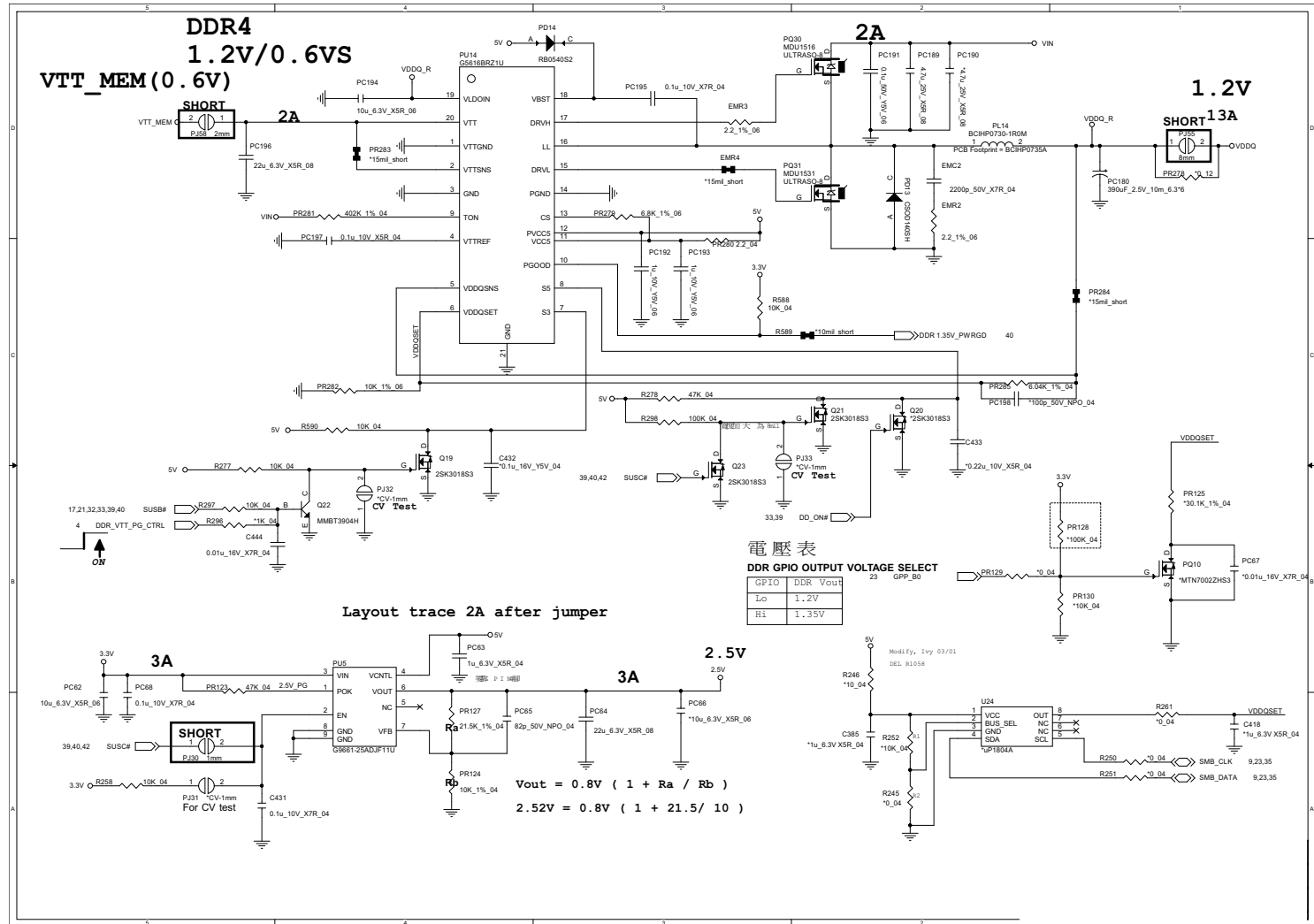

VCore, VCCGT Output Stage

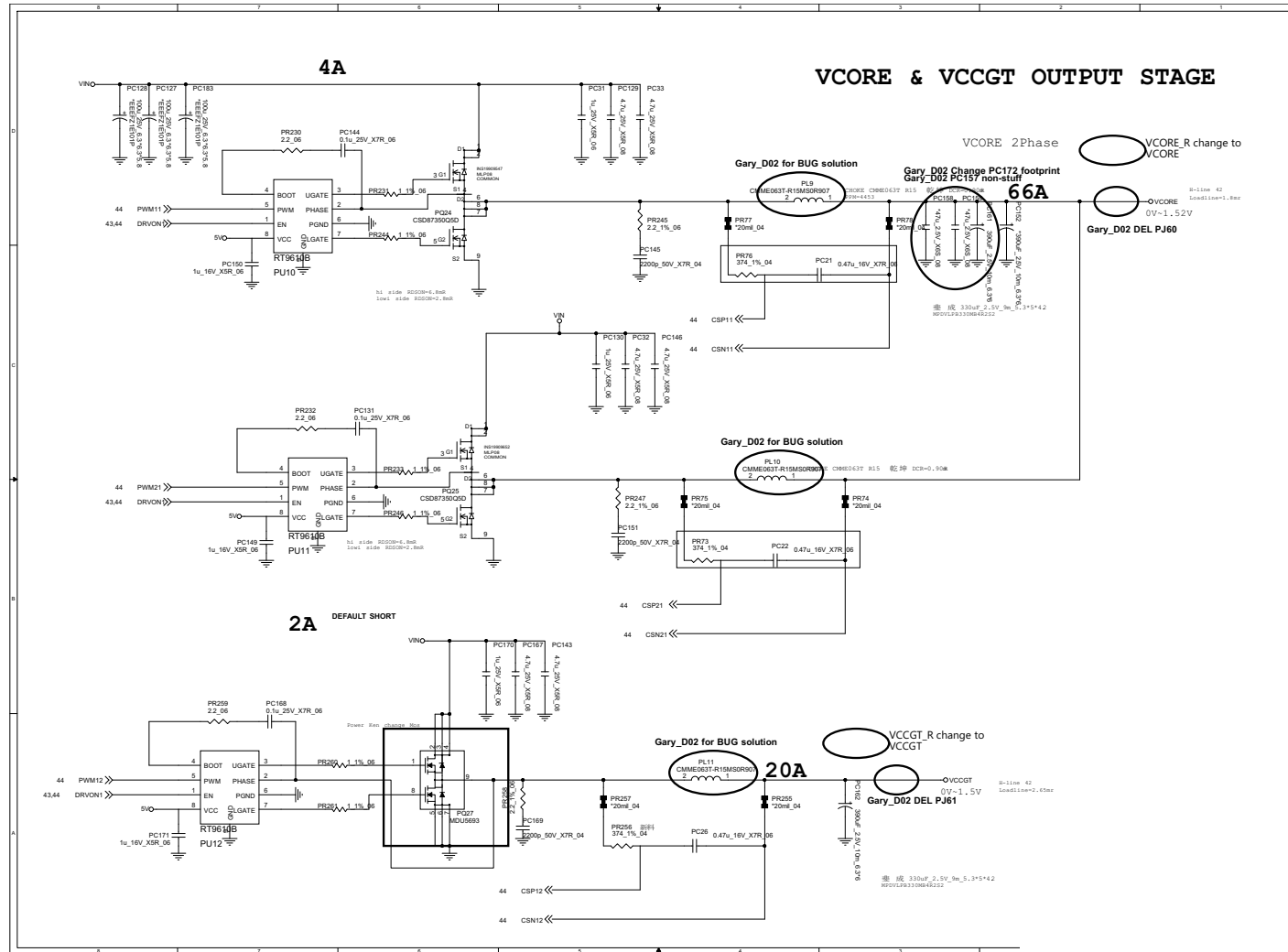

Sheet 42 of 55
VCore, VCCGT
Output Stage

B.Schematic Diagrams

Schematic Diagrams

VCC_Core, VCCGT

Sheet 43 of 55
VCC_Core, VCCGT

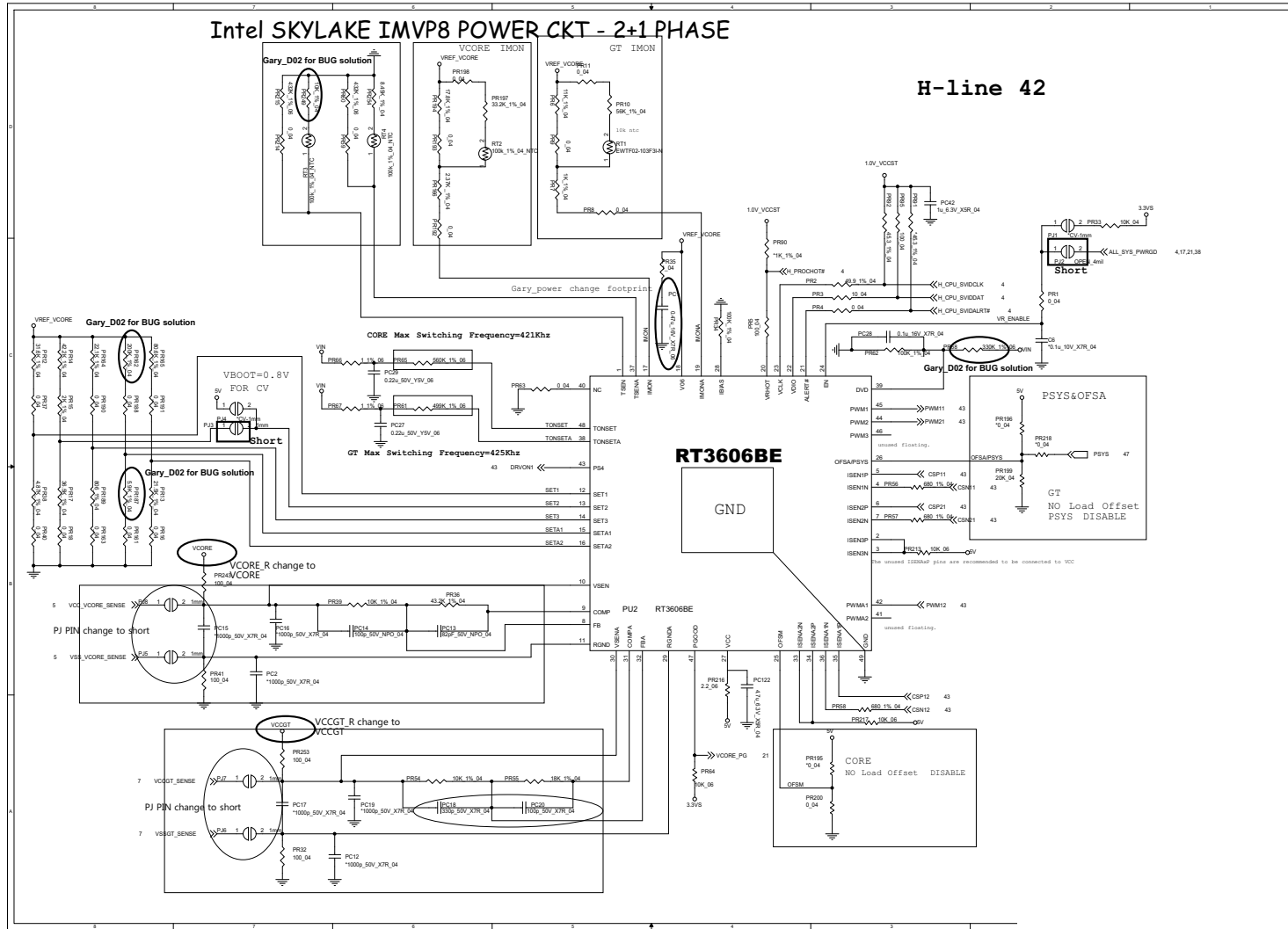

1.0DX_VCCSTG/VCCSFR_OC, 3.3VA

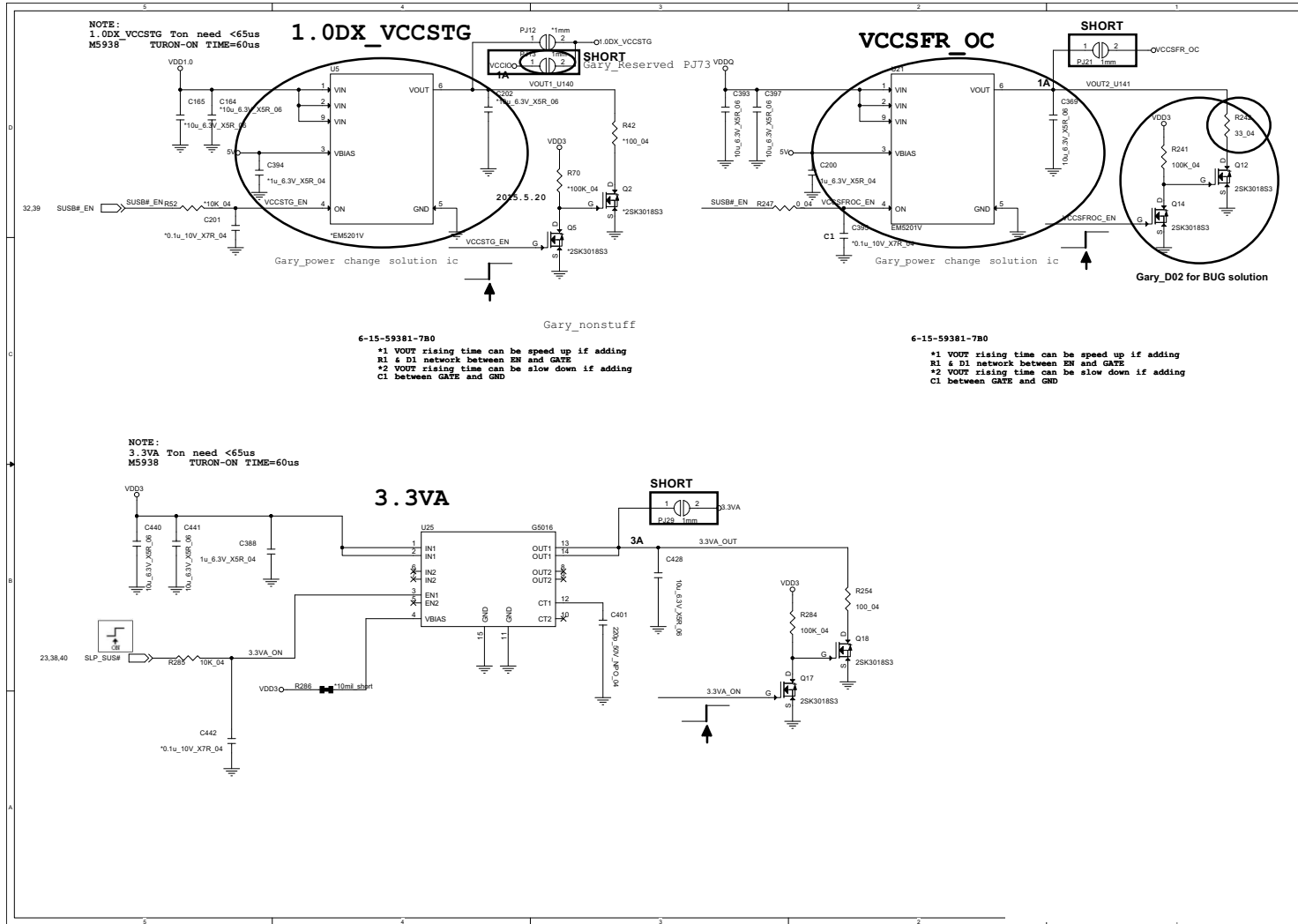

Sheet 44 of 55
1.0DX_VCCSTG/
VCCSFR_OC,
3.3VA

VCCSA

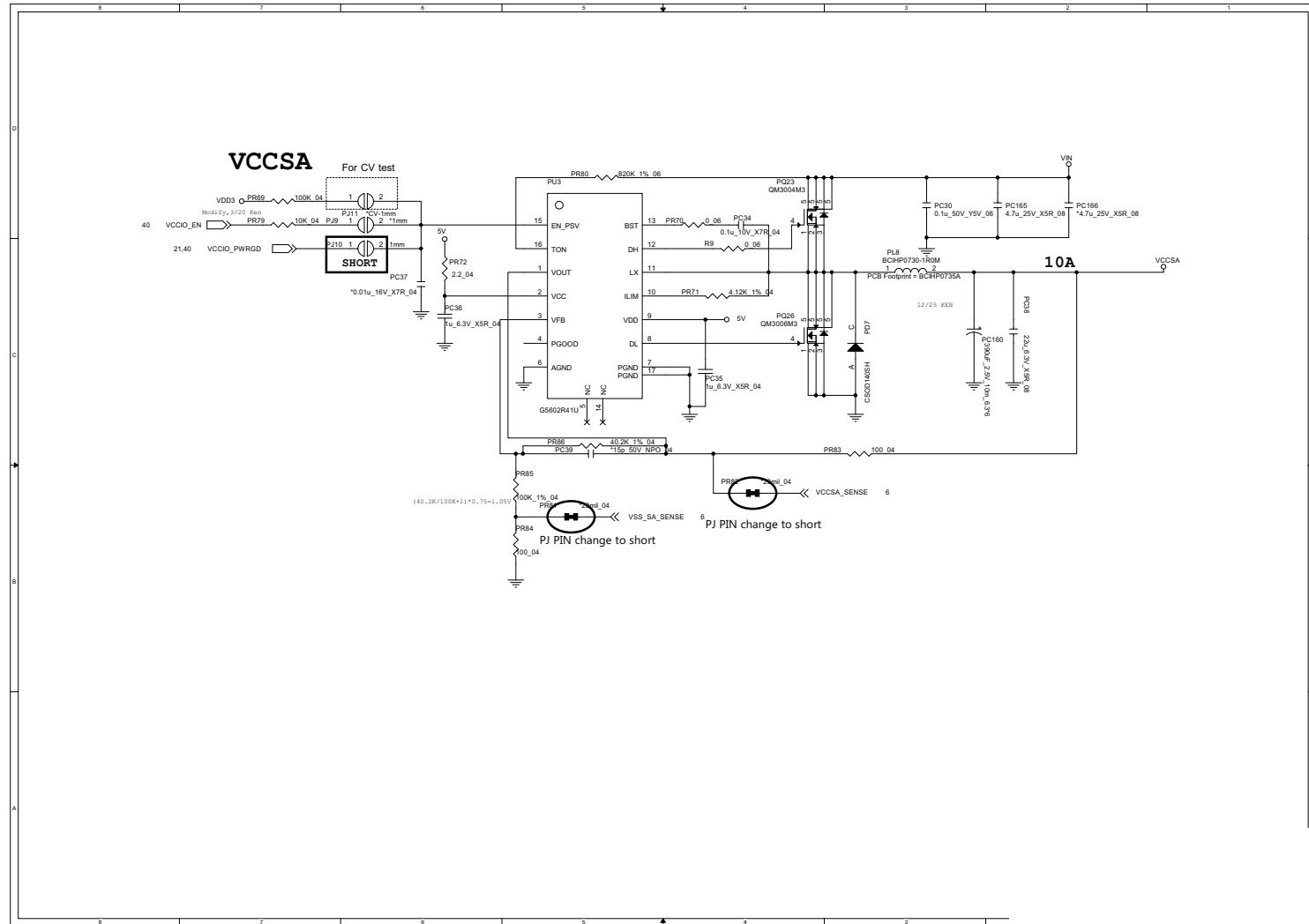

Sheet 45 of 55
VCCSA

AC_In, Charger

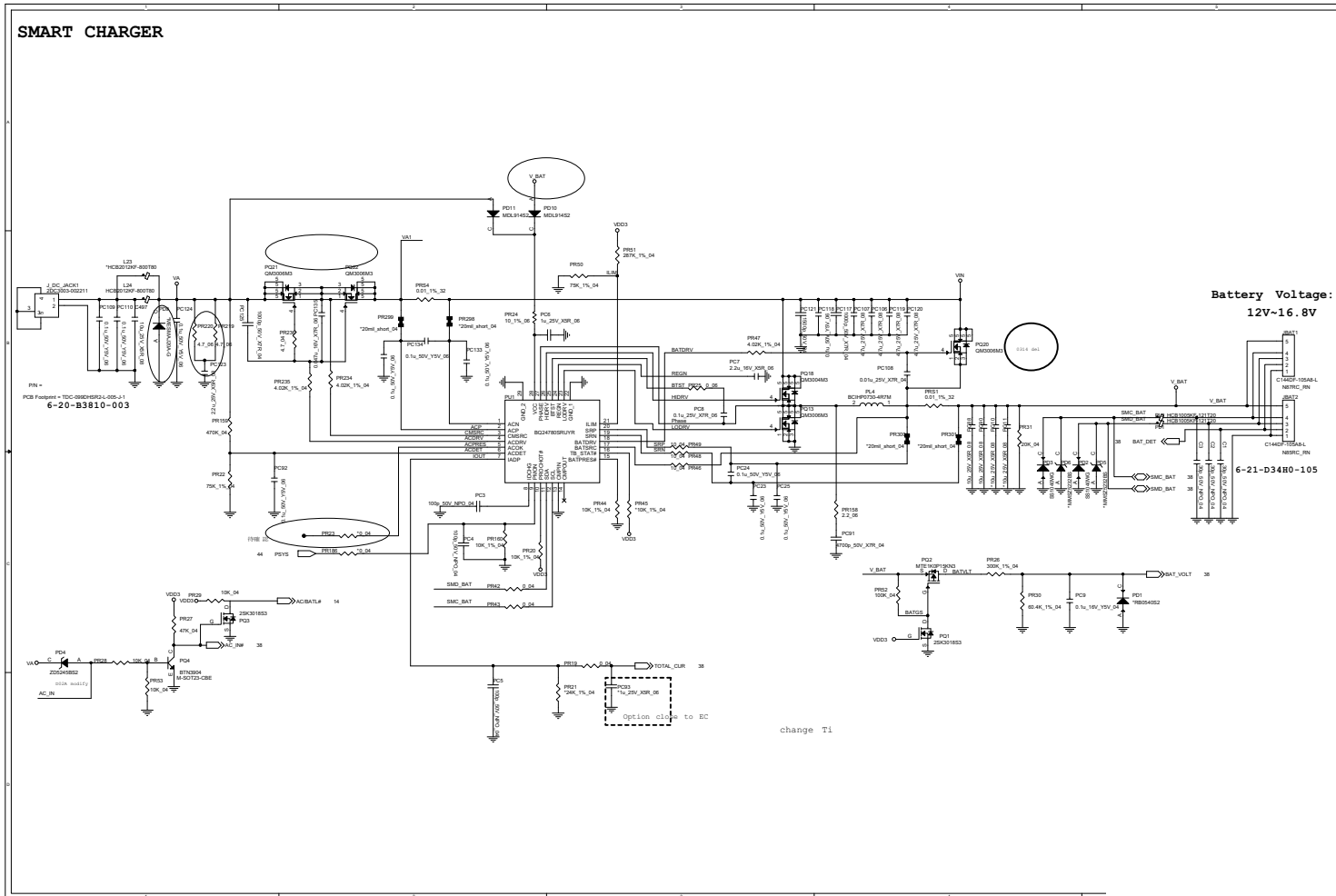

Sheet 46 of 55
AC_In, Charger

B.Schematic Diagrams

NVDD

Sheet 47 of 55
NVDD

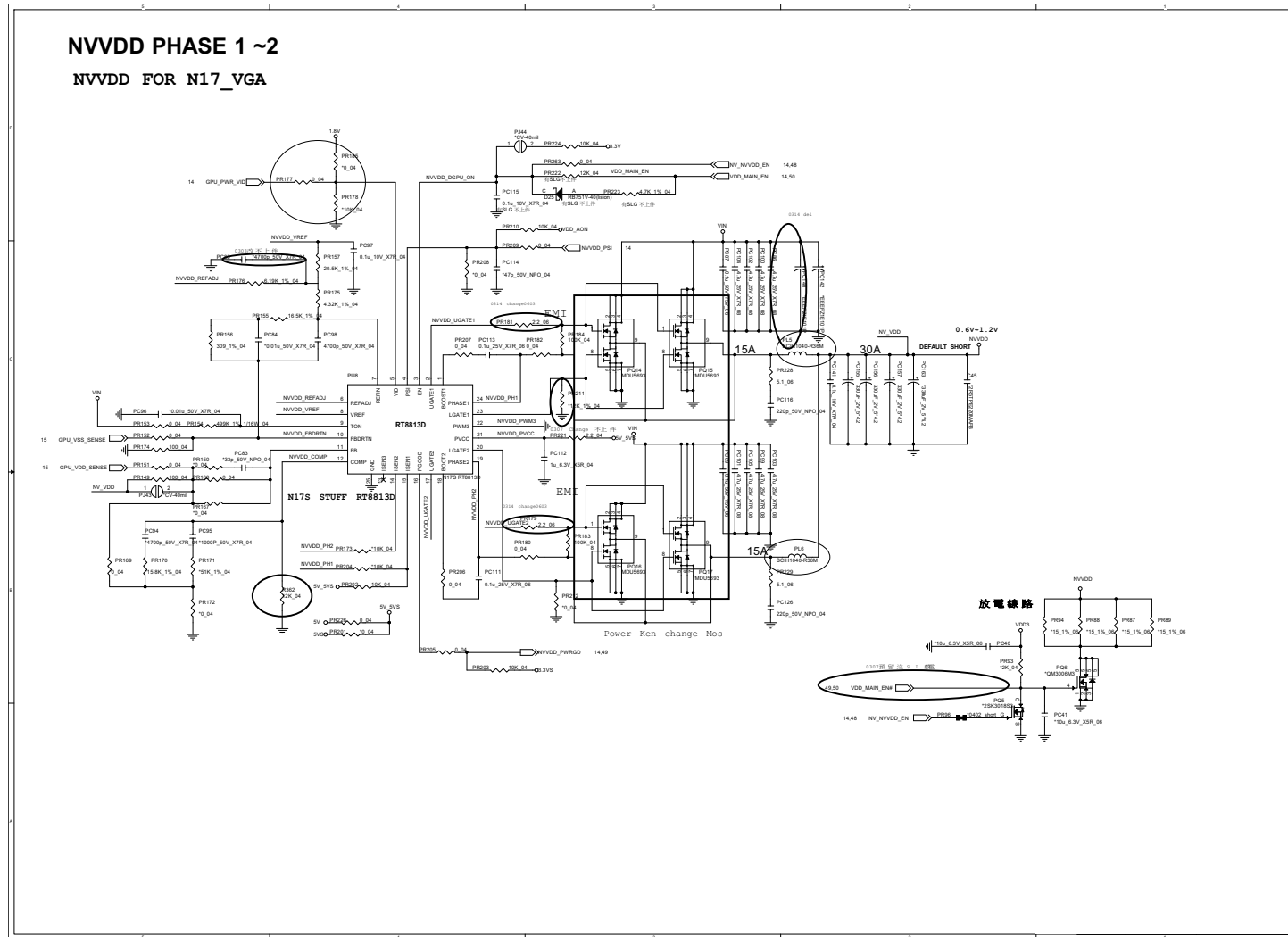

FBVDDQ

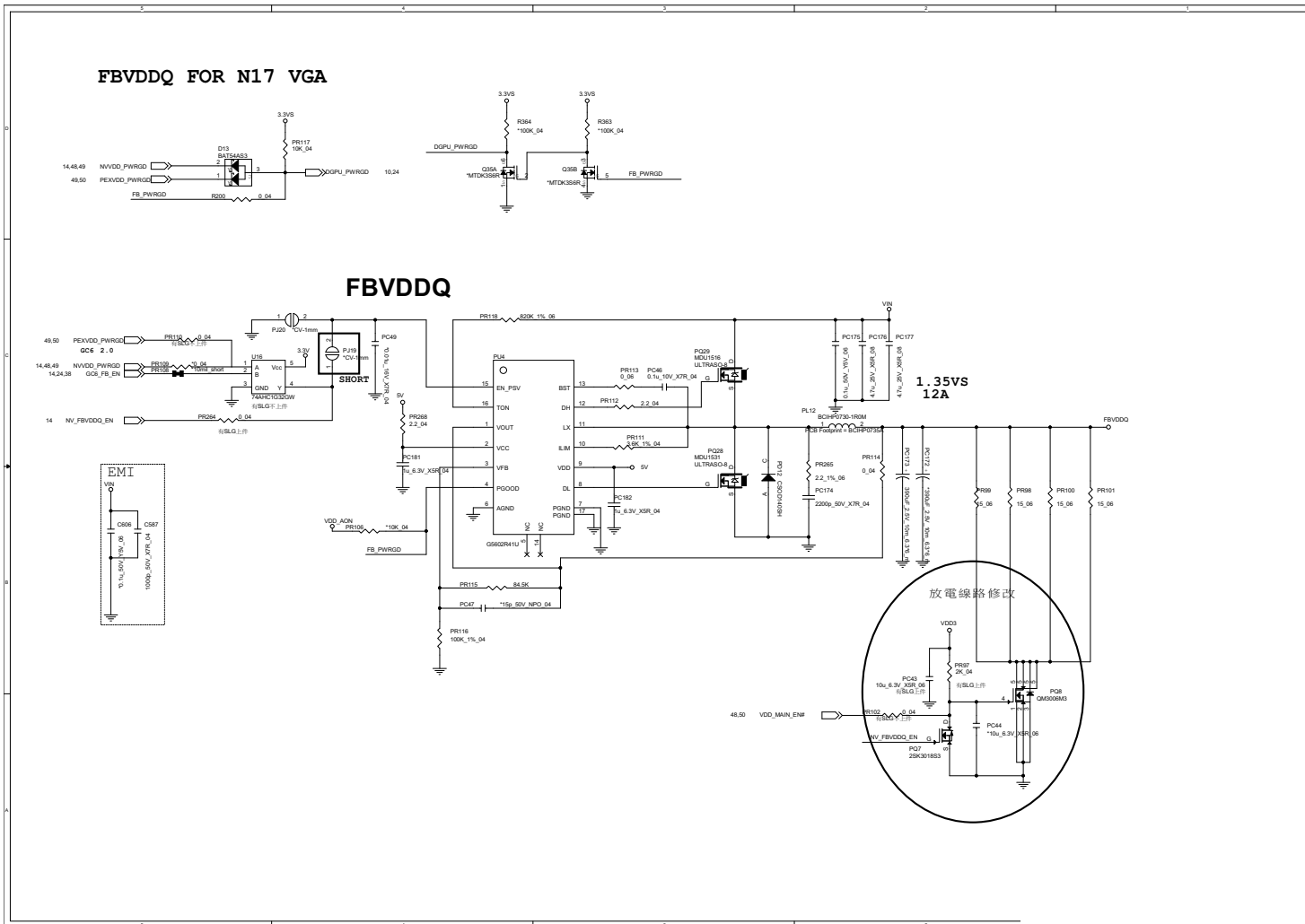

Schematic Diagrams

PEX_VDD/3V3

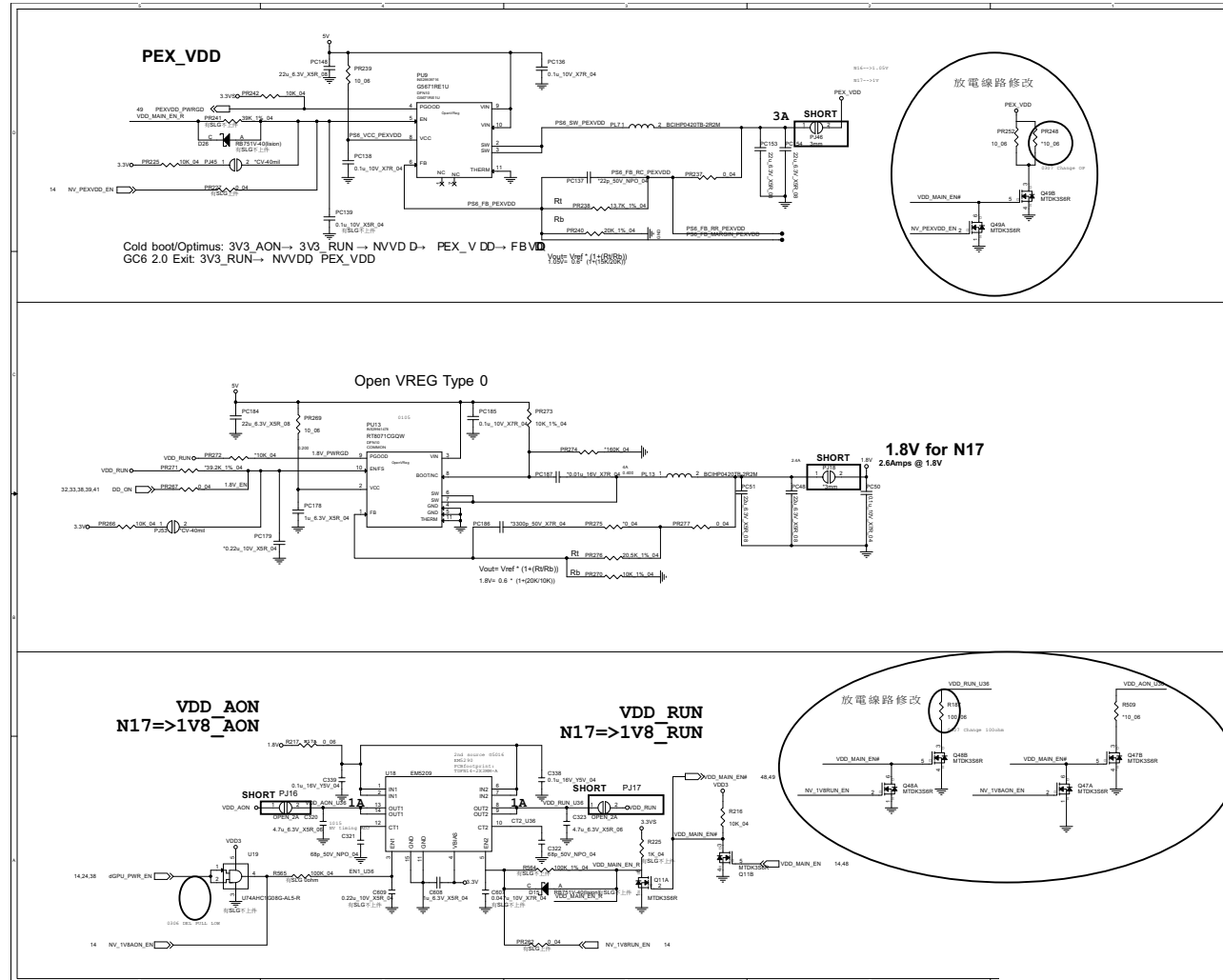

Sheet 49 of 55
 PEX_VDD/3V3

B.Schematic Diagrams

Audio Board

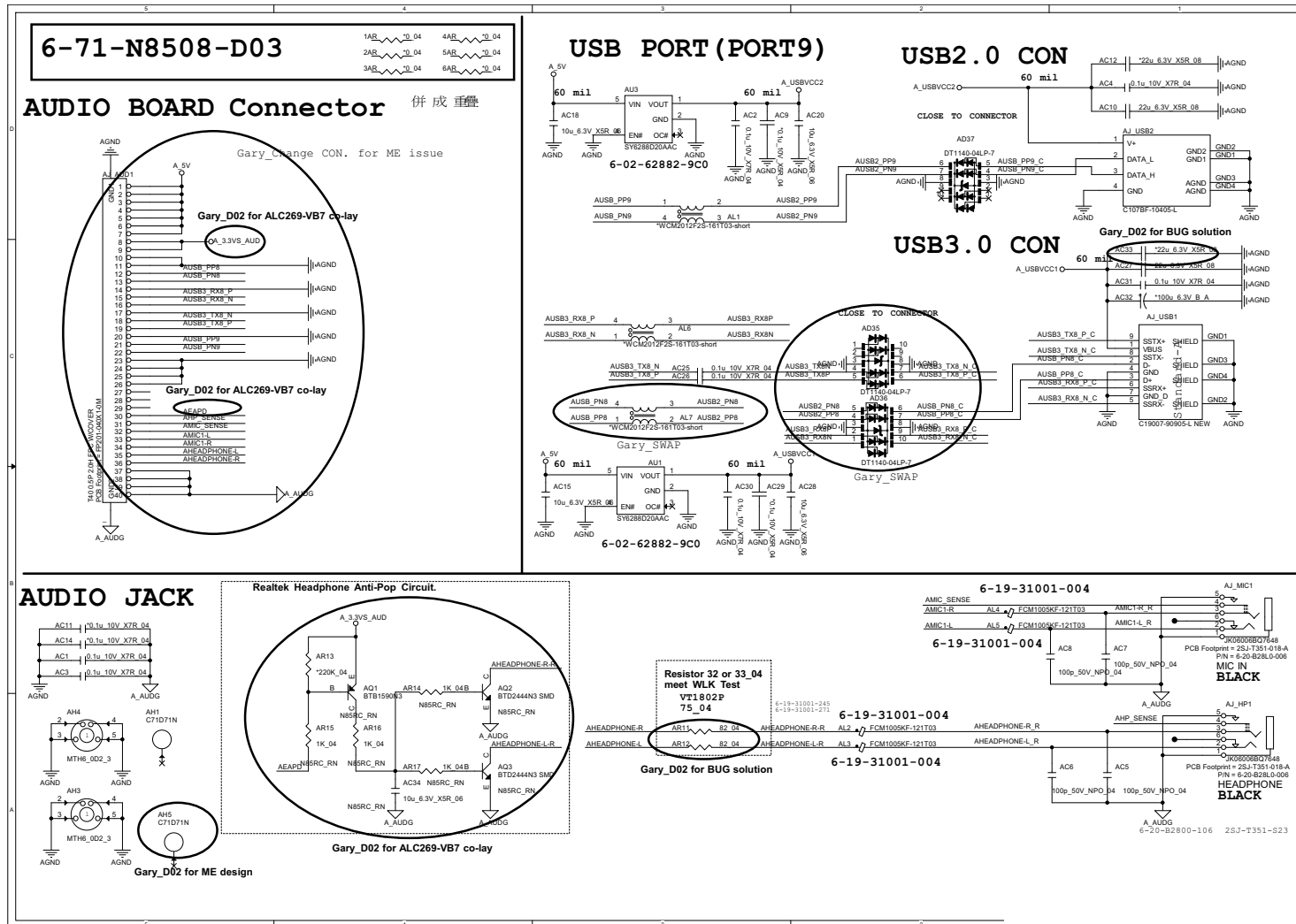

Sheet 50 of 55
Audio Board

B.Schematic Diagrams

Power Switch Board

Sheet 51 of 55
Power Switch
Board

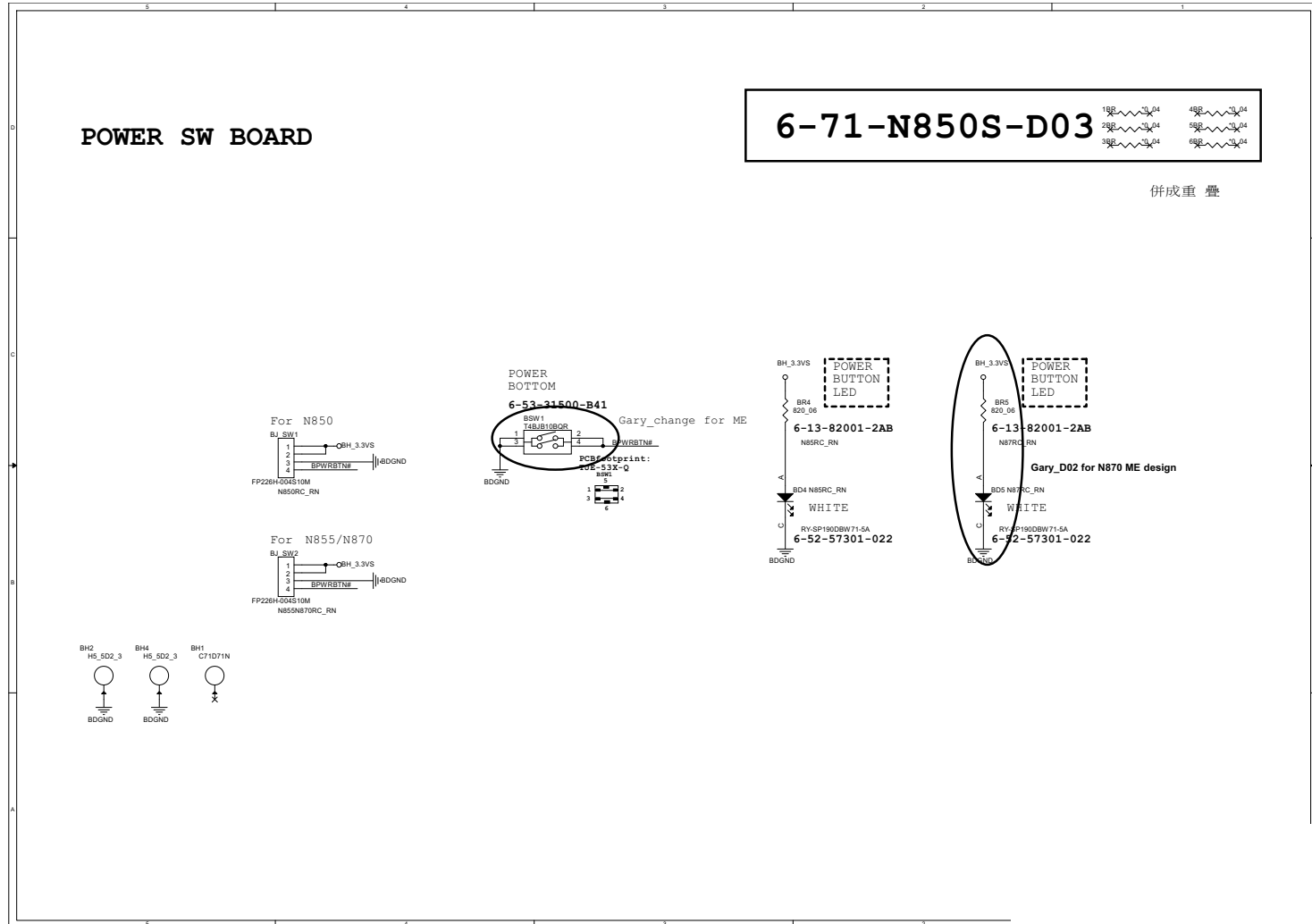

Hall Sensor Board

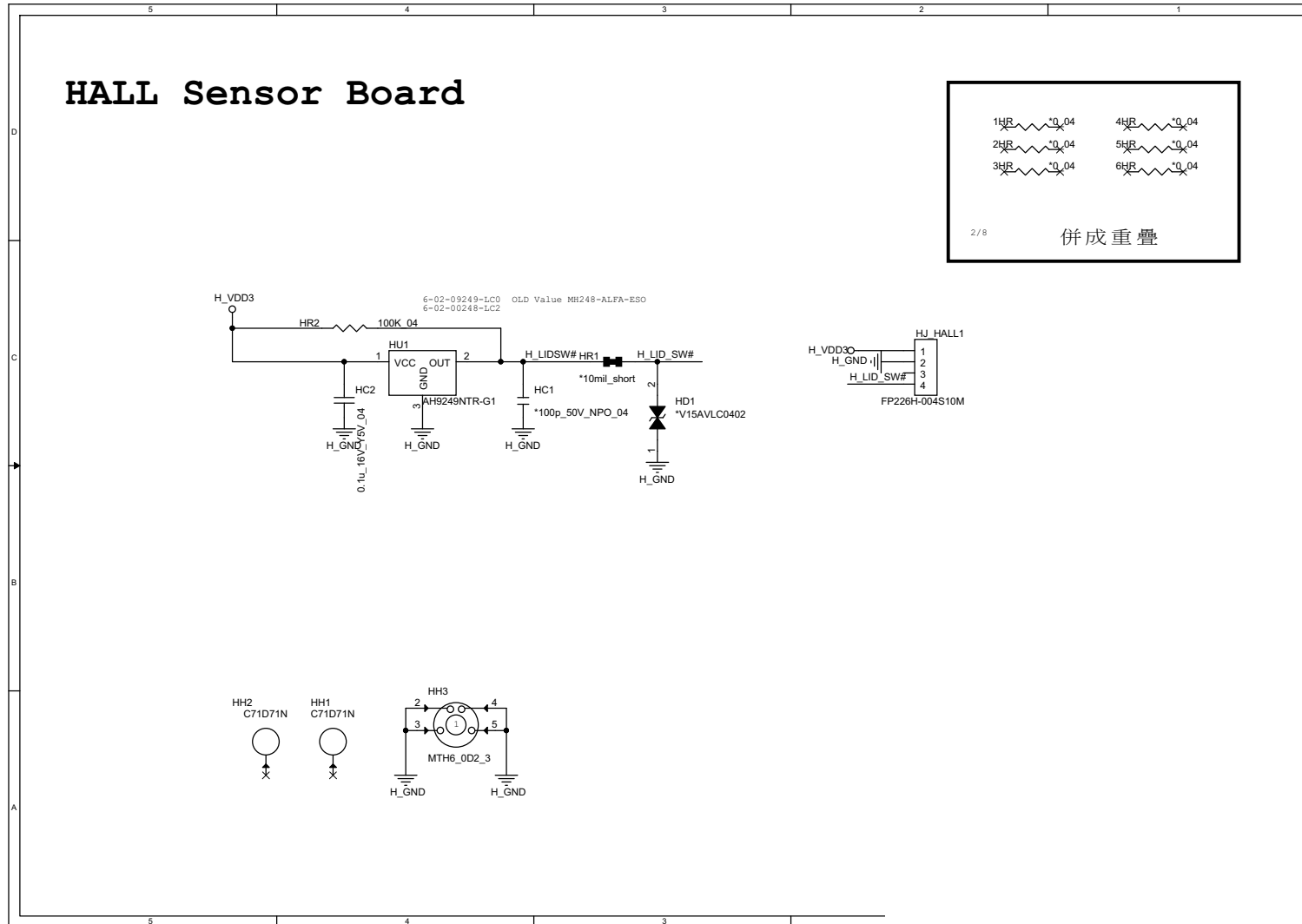

Sheet 52 of 55
Hall Sensor Board

Click Board

Sheet 53 of 55
Click Board

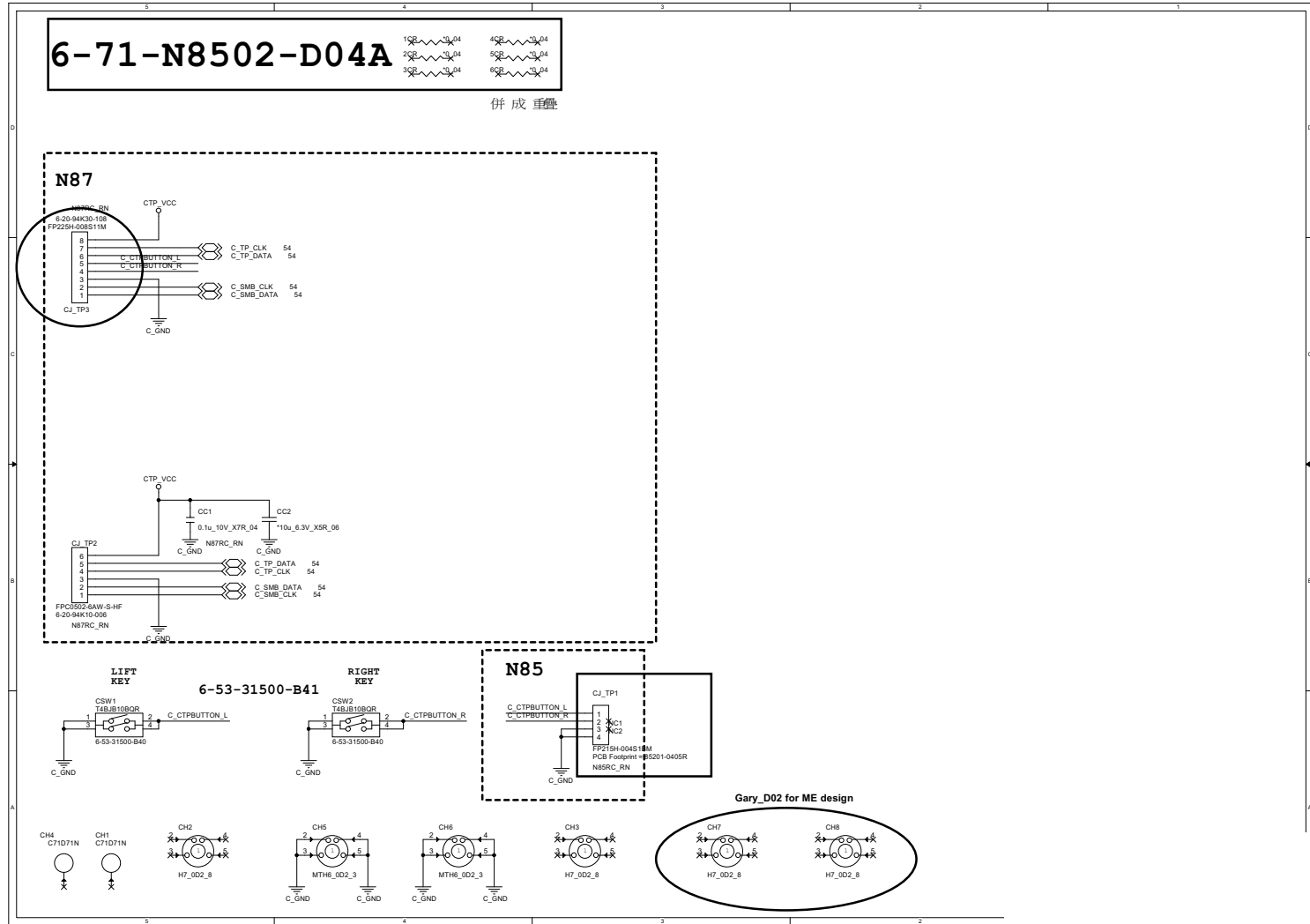

LED Board

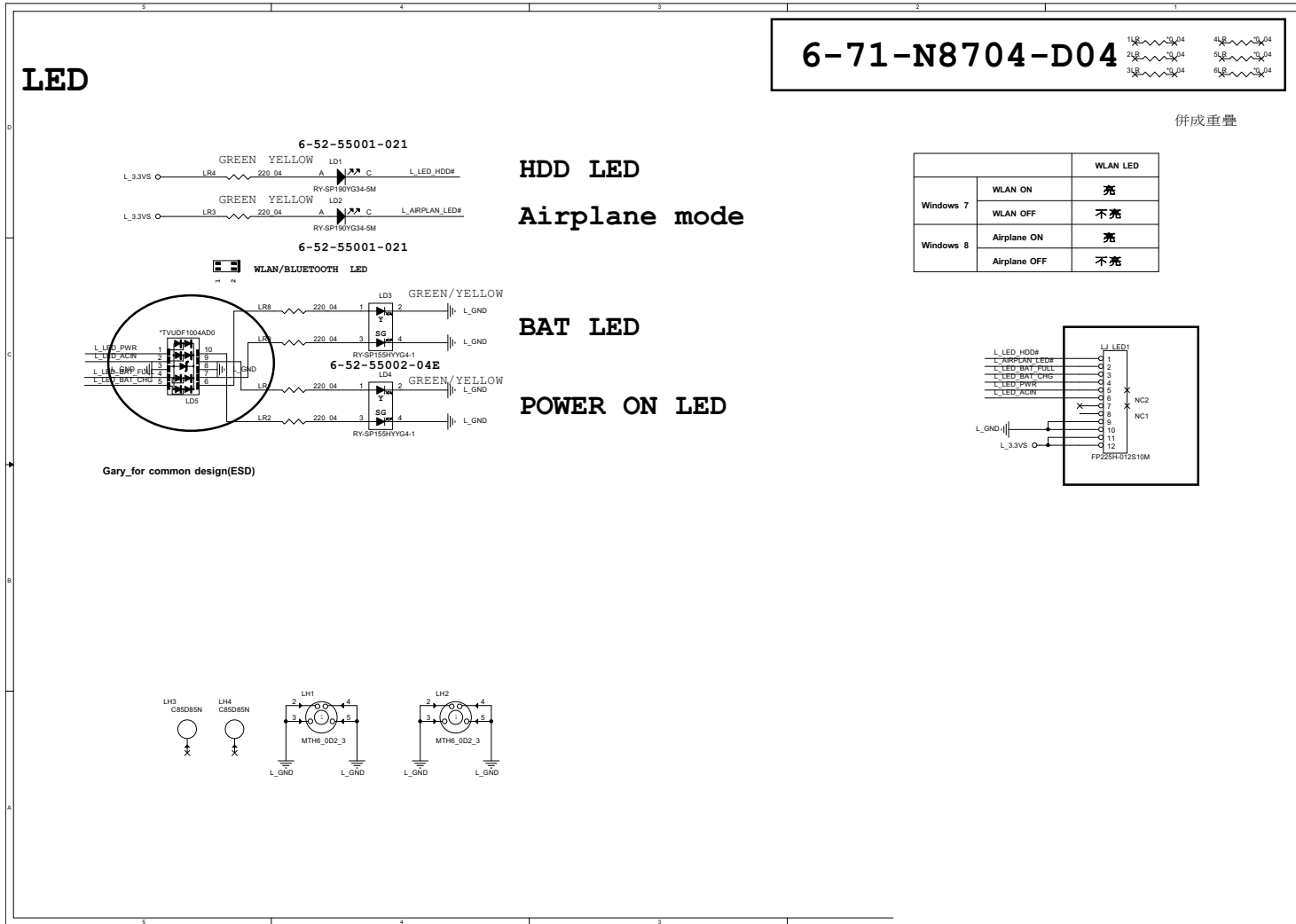

Sheet 54 of 55
LED Board

Power Sequence

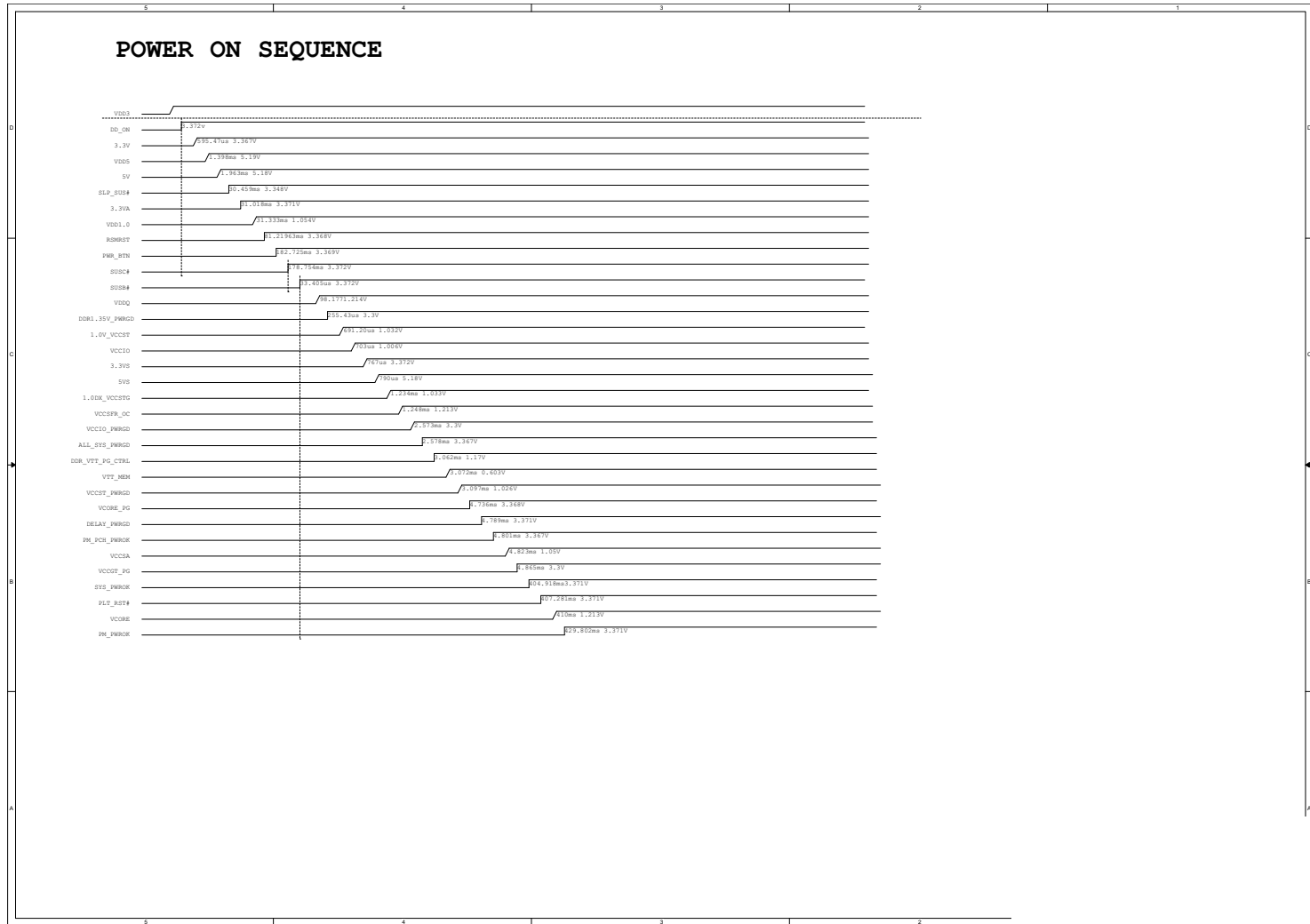

Sheet 55 of 55
Power Sequence

B.Schematic Diagrams

Appendix C: Updating the FLASH ROM BIOS

To update the FLASH ROM BIOS, you must:

- Download the BIOS update from the web site.
- Unzip the files onto a bootable CD/DVD/USB Flash Drive.
- Reboot your computer from an external CD/DVD/USB Flash Drive.
- Use the flash tools to update the flash BIOS using the commands indicated below.
- Restart the computer booting from the HDD and press **F2** at startup enter the BIOS.
- Load setup defaults from the BIOS and save the default settings and exit the BIOS to restart the computer.
- After rebooting the computer you may restart the computer again and make any required changes to the default BIOS settings.

Download the BIOS

1. Go to www.clevo.com.tw and point to **E-Services** and click **E-Channel**.
2. Use your user ID and password to access the appropriate download area (BIOS), and download the latest BIOS files (the BIOS file will be contained in a batch file that may be run directly once unzipped) for your computer model (see sidebar for important information on BIOS versions).

Unzip the downloaded files to a bootable CD/DVD or USB Flash drive

1. Insert a bootable CD/DVD/USB flash drive into the CD/DVD drive/USB port of the computer containing the downloaded files.
2. Use a tool such as Winzip or Winrar to unzip all the BIOS files and refresh tools to your bootable CD/DVD/USB flash drive (you may need to create a bootable CD/DVD with the files using a 3rd party software).

Set the computer to boot from the external drive

1. With the bootable CD/DVD/USB flash drive containing the BIOS files in your CD/DVD drive/USB port, restart the computer and press **F2** (in most cases) to enter the BIOS.
2. Use the arrow keys to highlight the **Boot** menu.
3. Use the “+” and “-” keys to move boot devices up and down the priority order.
4. Make sure that the CD/DVD drive/USB flash drive is set first in the boot priority of the BIOS.
5. Press **F4** to save any changes you have made and exit the BIOS to restart the computer.



BIOS Version

Make sure you download the latest correct version of the BIOS appropriate for the computer model you are working on.

You should only download BIOS versions that are **V1.0X.XX or higher** as appropriate for your computer model.

Note that BIOS versions are not backward compatible and therefore **you may not downgrade your BIOS to an older version** after upgrading to a later version (e.g if you upgrade a BIOS to ver 1.0X.05, you **MAY NOT** then go back and flash the BIOS to ver 1.0X.04).

BIOS Update

Use the flash tools to update the BIOS

1. Make sure you are not loading any memory management programs such as HIMEM by holding the **F8** key as you see the message “**EFI Shell**”. You will then be prompted to give “**Y**” or “**N**” responses to the programs being loaded by EFI Shell. Choose “**N**” for any memory management programs.
2. You should now see **DISK fsX:\>** (X is the designated drive number for the CD/DVD drive/USB flash drive).
3. **Type the following command:**

fsX:\> Flash.nsh

4. The utility will then proceed to flash the BIOS.
5. You should then be prompted to press any key to restart the system or turn the power off, and then on again but make sure you remove the CD/DVD/USB flash drive from the CD/DVD drive/USB port before the computer restarts.

Restart the computer (booting from the HDD)

1. With the CD/DVD/USB flash drive removed from the CD/DVD drive/USB port the computer should restart from the HDD.
2. Press **F2** as the computer restarts to enter the BIOS.
3. Use the arrow keys to highlight the **Exit** menu.
4. Select **Load Setup Defaults** (or press **F3**) and select “**Yes**” to confirm the selection.
5. Press **F4** to save any changes you have made and exit the BIOS to restart the computer.

Your computer is now running normally with the updated BIOS

You may now enter the BIOS and make any changes you require to the default settings.